

Refrigerator
Model RM 182 van Fridge
Westfalia Execution

CORRECTION! 12 V FUSE / FLAME INDICATOR
 THE 12 V FUSE AND THE FLAME INDICATOR (PAGE 4-5) ARE NOT
 LOCATED IN THE CONTROL PANEL OF THE REFRIGERATOR.
 THE 12 V FUSE IS INSTALLED IN THE GENERAL ELECTRICAL CIRCUIT.
 THE FLAME INDICATOR IS REPLACED BY A LIGHT EMITTING DIODE
 IN A SEPARATE CONTROL PANEL OF THE MOBILE HOME!

REVISED
 WIRING
 DIAGRAM

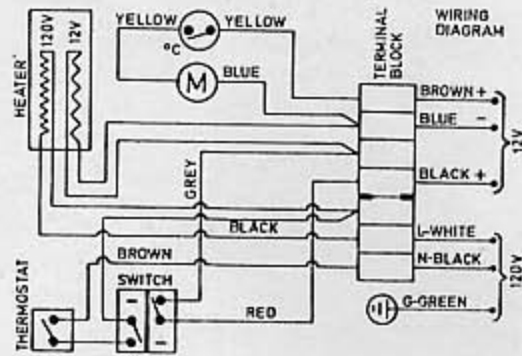

WIRING
 DIAGRAM

Operation by L.P. Gas and Electricity
(Dual Voltage 12/120V) for use in a mobile home or recreational vehicle.
Instructions for installation and use.

For your safety

If you smell gas:

1. Open the windows.
2. Don't touch electrical switches.
3. Extinguish any open flame.
4. Immediately call your gas supplier.

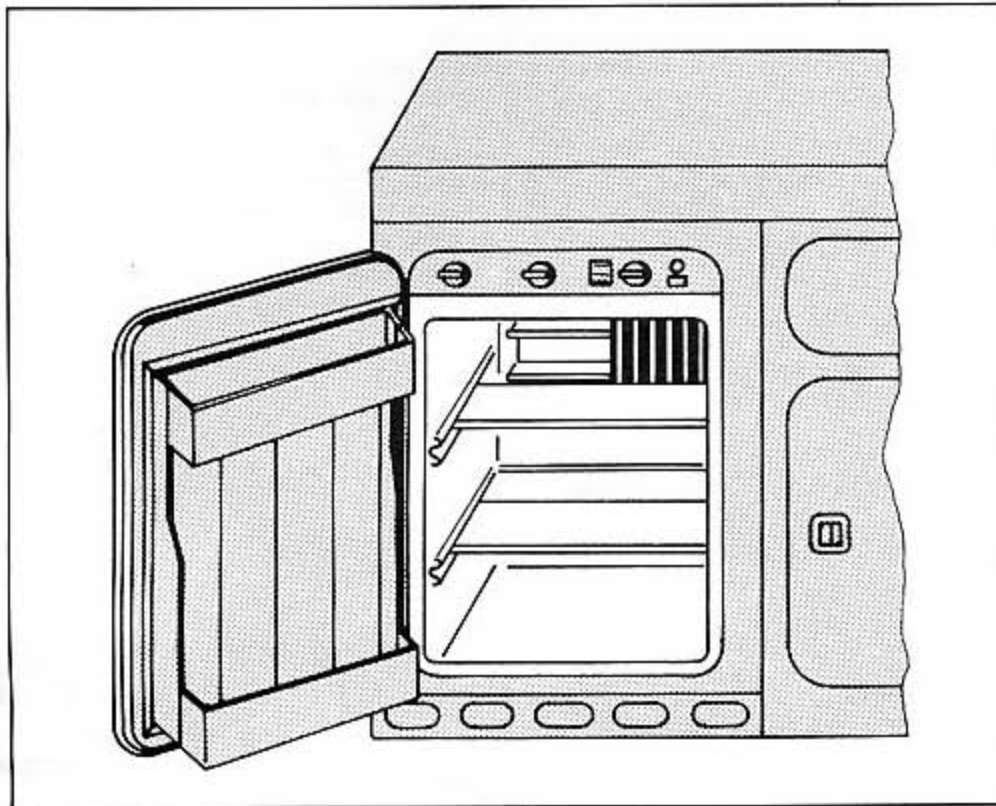

Instructions for installation

The design of this refrigerator has been certified by the American Gas Association and the Canadian Gas Association for Mobile Home or Recreational Vehicle Installation.

This certification is contingent, however, upon proper installation and the use of the venting components as shown in these instructions.

1. Installation

The installation of the refrigerator must comply with local codes or in the absence of local codes the following American National Standards and the Canadian Standards as applicable:

In the U.S.A.:

ANSI Z 223.1 – 1978 National Fuel Gas Code.

ANSI C 1 – 1978 National Electrical Code.

In Canada:

CSA Std. Z 240.4 – Gas Equipped Recreational Vehicles and Mobile Housing.

Note:

Will be replaced by CSA Stds. Z 240.4.1. and Z 240.4.2. when available.

CSA Std. Z 240.6.1. – Electrical Requirement for Mobile Housing.

CSA Std. Z 240.6.2. – Electrical Requirements for Recreational Vehicles.

The overall dimensions of the refrigerator are given before and the dimensions of the recess to house it are given in fig. 3. These allow sufficient clearances for the refrigerator to be inserted and withdrawn.

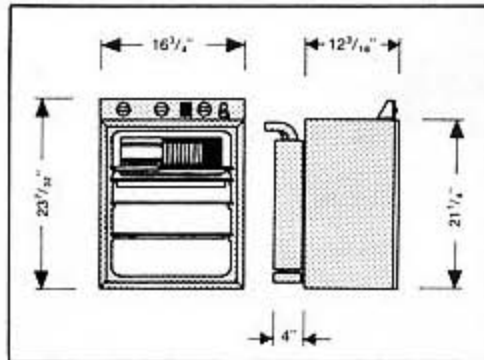
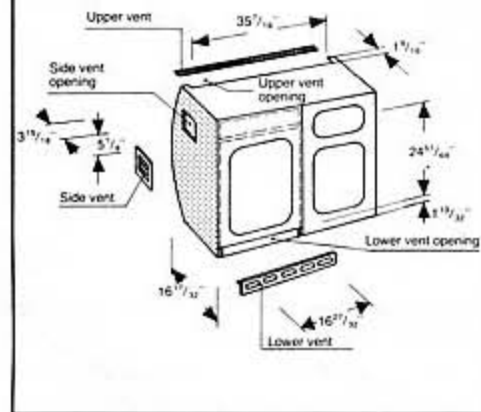

Fig. 3



The following minimum clearances must be allowed at the back and over the top for air circulation over the cooling unit: Clearance from rear edge of outer casing of the refrigerator — 5 inches. Clearance above top of the unit fins — 3 inches. (This is the minimum height which can be allowed over the condenser fins). The more ventilation you provide, the better the performance you can expect from the refrigerator. The refrigerator should be installed in accordance with the illustrations on page 3.

The sealed combustion unit (fig. 2) is made up of the burner, a fresh air in and outlet pipe, and a vent/air-intake assembly in the wall.

Fig. 2

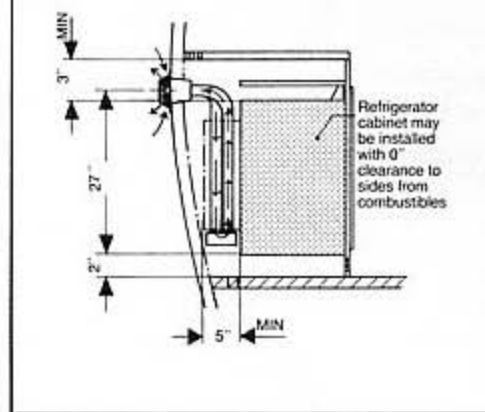

The burner unit is completely sealed off from the interior of the van by means of the two special in and outlet ways in the vent/air intake assembly, fresh air is drawn in and the products of combustion are safely vented to the outside air.

The in and outlet housing is mounted into the van wall, is connected by means of flexible pipes and can be situated safely on a sloping surface.

Construction adjacent to and above the flue outlet must be of noncombustible material. The refrigerator is to be secured in the recess by screws or bolts through the cabinet side walls (see note page 12).

Keep appliance clear and free from loose combustible materials, gasoline and other flammable vapors and liquids.

Combustion air, flue products and ventilation air

The absorption cooling unit is of the air-cooled type and it is of the utmost importance that air circulates free over the unit and that the internal air vents (fig. 1) are always kept open. Details of the vent system, which is of a so called sealed combustion type, are given in fig. 1 and fig. 2. This vent has been tested for use with this refrigerator and contains the proper size openings, it must be installed as is and must not be modified in any way. The wall mounted vent kit with its tube connections for fresh air and flue gases is air tight and must be installed with care to maintain this air tightness.

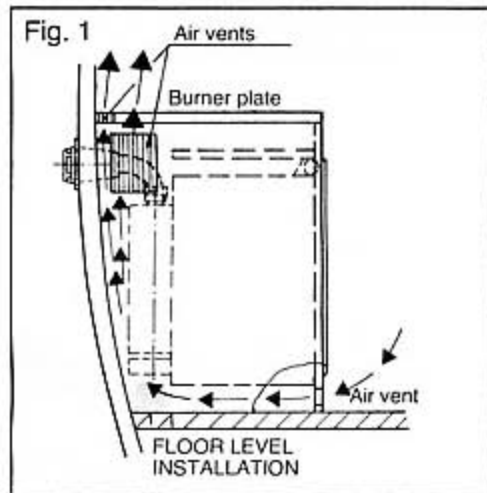

2. Gas pressure

The gas bottle must be fitted with a pressure regulator to reduce the pressure to 11 inches water gauge. The burner is fitted with a jet No. 24, which is suitable for use on Propane and Butane gas at a supply pressure of 11 inches water gauge.

3. Gas connections

The supply pipe from the pressure regulator on the gas bottle to the refrigerator should preferably be of copper or of another type approved for use with continuously operating L.P. gas appliance and should be connected to the inlet of the gas valve to the left side of the refrigerator. After connecting all gas connections should be checked for leaks in accordance with the Installation Standards detailed on Page 1.

4. Electrical connections

When operating on electricity the cooling unit operates by means of two separate 85 W heating elements, one for use on 120 V a.c., the other for use on 12 V d.c. The unit must be electrically grounded in accordance with the electrical Installation Standards detailed on Page 1.

a) 120 Volts a.c.:

Warning: Electrical Grounding Instructions.

This appliance is equipped with a three-prong (grounding) plug for your protection against shock hazards and should be plugged directly into a properly grounded three-prong receptacle. Do not cut or remove the grounding prong from this plug.

The cord is approximately 4 feet long and a grounded three prong receptacle should be installed in an accessible position within reach of the plug.

b) 12 Volts d.c.:

At the top of the refrigerator under the smaller cover you will find the 12 Volt connection. Take off the cover from the box by removing the screws and the terminal block will be visible. From these, the refrigerator must be connected to the main battery in the vehicle by means of 3 wires, passing through the entry opening (temporarily sealed with a dustcap) of the box. Polarity is not important, but the body or chassis of the automobile or vehicle should not be used as a substitute for one of the wires.

The current is 7.0 amp, when the refrigerator is operating on 12 Volts, therefore the wiring from the battery to the refrigerator must be heavy enough to carry this load satisfactorily without voltage drop. The minimum size of the wiring used is to

be 14 AWG.

The connections to the battery should be made using wire type clamps with tightening bolts to ensure good contact with the battery poles.

To prevent the refrigerator operating and draining the battery when the engine is switched off it is recommended that an automatic cutout relay is installed between the battery and the refrigerator so that the refrigerator will not draw current from the battery when the ignition is switched off.

Do not connect lights or any other electrical components to the wiring from the battery to the refrigerator.

In order to improve the cooling performance under difficult built-in situation and high ambient temperatures a 0,6 W ventilator is switched on automatically when the temperature around the condenser fins is about 140° F and switched off at 124° F. The ventilator is connected to the 12 V system.

c) Fuse.

On the front of the control panel (see. fig. 4) in an insulated holder, is a 10 amp. fuse, which is to protect the 12 Volt circuit in the event of a short. If the fuse burns out, trace the cause and correct it before fitting a similar 10 amp. fuse and reconnecting.

5. Gas connections.

Connections should be checked for leaks by applying a soap-water solution over them and watching for bubbles. Do not use a flame. Thereafter, all connections should be checked at least once a month. The refrigerator gas equipment must not be subjected to an internal pressure exceeding 22 inches of water column.

Instructions for use

6. Leveling

Maximum cooling performance is obtained with the refrigerator leveled in both directions.

Fig. 4

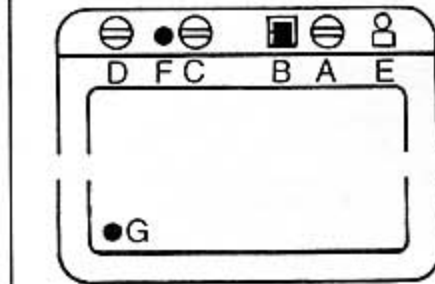

7. Starting the refrigerator

The gas and electric controls are located at the top front of the refrigerator and are accessible by opening the refrigerator door.

The plastic cover cup on the flue vent must be removed before the refrigerator is put into operation. Save the cover for future use.

The cover should be put on when washing the motorhome or when using a car wash. This to prevent water to enter into the burner. The cover must be taken off when the refrigerator is in operation.

a) Control Panel – Explanation, (Fig. 4)

- .,D' Button for operating the air pump as well as the piezo gaslighter (fig. 5). It is mounted pivotally to facilitate manipulation.
- .,F' Push – button for ignition control.
- .,C' Rotating button for thermostat. The combined electro – gas thermostat is used for 120 V as well as for gas operation; the 12 volts circuit has not thermostat control. If the button is turned completely to the left over the point where a slight resistance is felt, the 120 volt circuit is switched out. During gas operation the same position corresponds to MIN-position (gas operation is turned off only by closing the gas valve (A)).
- .,B' Push – button for voltage selection.

- ,A' Gas valve.
,E' Screw plug for fuse and flame indicator sight peep.

- b) Explanations concerning the Air Pump. resp. Piezo Gas-Lighter Function of Control Button (B) (Fig. 4).

To use button (D) as an air pump, pull it out completely and push it back swiftly to rest position (fig. 5).

To use the same button (D) for actuating the piezo-lighter, pull it out beyond rest position and push it in until it clicks, beyond the rest position, (fig. 5).

- c) L.P. Gas Operation: Lighting the Burner (see fig. 4, page)

- 1) Put voltage selection switch (B) to position GAS, then turn on gas valve (A).
- 2) Turn gas/electric thermostat knob (C) to MAX setting.
- 3) a) Operate button (D) as airpump about 5 times.
b) Then, push in ignition control button (F) hold it down and actuate simultaneously button (D) as piezo gas-lighter, several times rapidly in succession until the flame burns.

If the burner is alight, the red pointer of the flame indicator (E) is going slowly from the white into the green field. When the pointer is in the green field, keep the knob (F) pushed for another 10 seconds, then release it, but check, that the pointer remains in the green field. If the burner is

Fig. 5

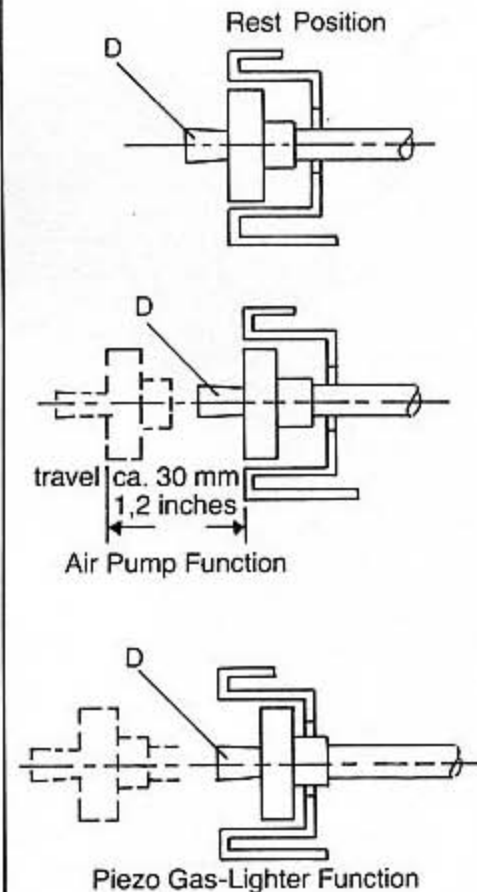

alight, you can also see the flame through the pilot sight hole at the left inside the cabinet. The ice-tray shelf should show signs of cooling after two hours.

Notes: When connecting a new gas bottle or if the unit has been out of operation for about 24 hours, it may happen that you don't succeed immediately to light the burner as described above. In this case proceed as follows:

Turn thermostat button (C) to 'MAX' position, let in the gas by holding down the ignition control button (F) during approx 20 seconds. Thereafter, release button (F) and actuate button (D) approx 20 times as an airpump. Thereafter light the burner as described under 3a, 3b.

If the gas has to be relit when the evaporator is still cold, the thermostat dial (C) must first be turned to MAX and returned to its normal setting after the burner is alight. The refrigerator has a flame failure device which will automatically shut off the gas to the burner if the flame is blown out. While the knob (F) is pushed, this device is temporarily inoperative.

- d) Electric operation (see fig. 4, page 5)

1. See that the gas valve (A) is turned off.
2. Put voltage change switch (B) to the appropriate voltage.
3. Connect the correct voltage electricity supply and turn thermostat knob (C) to coldest setting.

Notes: The 12 Volt circuit is not thermostatically controlled.

8. Regulation of temperature.

With the thermostat knob set at mid position, the cabinet will automatically maintain a suitable temperature for ordinary food storage. Usually, no further adjustment will be needed, but in hot weather, or when more cooling is required, the knob must be turned to a higher position. If less cooling is required, the knob should be turned to a lower position.

9. Storing food in the refrigerator.

To prevent drying out and the transfer of flavors from one food to another, food should always be stored in covered dishes, plastic bags or wrapped in foil or waxed paper. **NEVER PUT HOT FOOD INTO THE REFRIGERATOR.** Avoid using larger dishes and do not stock food containers too closely as this interferes with the circulation of cold air within the cabinet.

10. Ice-Making.

Fill the ice-trays with water within $\frac{1}{8}$ " from the top and place them on the ice-tray supports. When ice has formed the ice-tray can be released from the shelf by lifting one corner. Do not use a lever. Any unwanted ice should be left in the divider and replaced in the tray, empty spaces being refilled with water. Ice will be made more quickly when the thermostat knob is set to „MAX“. When ice has formed be

sure to turn back the knob to its normal setting, otherwise the food in the cabinet may become too cold.

11. Defrosting.

Frost will form gradually on the cooling fins. It is a mistake to assume that an accumulation of frost gives a colder cabinet. For the most efficient and economical operation, the refrigerator should be defrosted regularly, about every ten to fourteen days, depending on the particular conditions of use.

To defrost, turn off the gas valve or switch off the electricity supply to the refrigerator, depending upon which is being used, remove the ice-trays and leave the cabinet door open. The frost will melt and drop into the drip tray.

Any remaining drops on the ice-tray support and in the refrigerator should be wiped up with a clean cloth.

When defrosting is completed, fill the ice-tray with fresh water, place them on the ice-tray support and restart the refrigerator.

Note: Do not attempt to defrost more quickly by means of any form of heat, otherwise the plastic surfaces may be damaged.

12. Cleaning.

Clean the refrigerator thoroughly, as necessary, particularly when it is to be out of

use for any period.

First defrost the cabinet as described in the previous item, then clean the shelves, cabinet interior and door with a clean cloth wrung out in warm water to which mild, non scented washing-up liquid detergent has been added. Wipe over with a clean cloth and dry thoroughly.

Do not wash any plastic parts in water that is more than hand hot and do not expose them to dry heat.

The outside of the cabinet should be wiped with a clean, damp cloth and polished with a clean soft duster.

NEVER USE STRONG CHEMICALS OR ABRASIVE CLEANING MATERIALS ON ANY PART OF THE REFRIGERATOR.

13. To shut down the refrigerator.

Switch off the electricity or turn off the valve controlling the gas supply to the refrigerator, as applicable.

When not in use, the refrigerator should be emptied, cleaned and dried and the door left slightly open, so that fresh air can circulate inside. The ice-tray should be emptied, dried and left handy on a shelf in the cabinet.

Points to remember

— If the vehicle has been out of use for a period, make sure all air vents are free from obstructions (e.g. bird's nest, etc.)

respective positions and be careful not to disturb other connections.

3. Open the sheet metal coat of the boiler insulation at the back of the refrigerator, set the heating element free by taking off the insulation from the tubes.

Then release the screw below the heating tube, pull it up and pull the insulation hoses from the 4 stranded wires.

4. Check that the new heater is of the correct type, then pull the insulation hose over the stranded wires, put the heating element completely into the heating tube and fasten the screw.

5. Put back the boiler insulation, packing it around the tubes and close the boiler casing.

6. Connect the leads to the terminal block and replace the cover, reconnect the refrigerator and test. If gas connections have been disturbed, test for leaks is as in item 14 (d).

B) Fuse

If there is no circuit when connected to 12 V, check that the fuse has not burnt out, see item 4 c.

16. Trouble shooting

If the refrigerator does not freeze satisfactory:

a) Check that the proper clearances for air circulation over the cooling unit at the back have been allowed, — see item 1.

b) Thermostat incorrectly used, — see item 8.

c) Evaporator (ice tray support) heavily covered with frost, — see item 11.

d) Air circulation around cooling unit restricted, — see item 1.

e) Flame has gone out:

Gas bottle used up... fit new bottle.

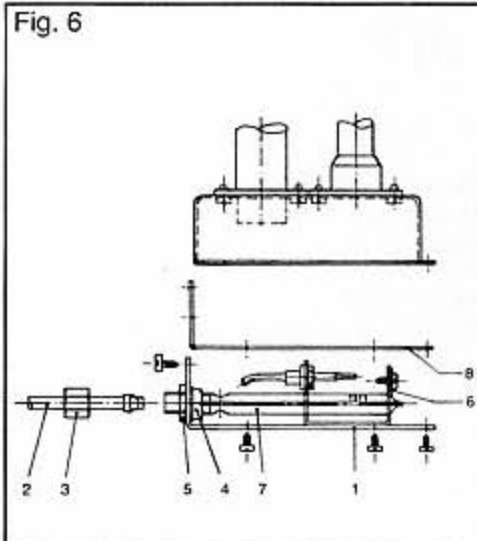

f) Wrong gas pressure at burner.. have pressure checked. Pressure at burner must not fall below 11 inches w.g. when thermostat is set on „MAX“.

g) 12 V operation. . burnt out fuse, — see item 4 c.

The following checkings can only be made when the refrigerator is taken out of its recess:

1. Connection between thermocouple and flame failure device body loose . tighten union (fig. 5) but do not overtighten.

2. Clogged thermostat by pass screw . . clean or exchange it.

3. Burner assembly loose . . . refit.

WIRING DIAGRAM

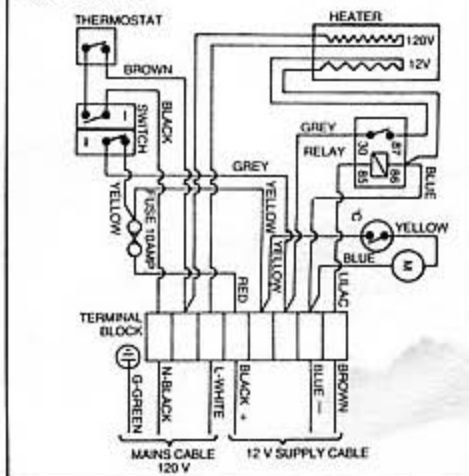

4. Jet orifice or burner gauze clogged. . see item 14 c.
5. Faulty operation of the thermostat. . thermostat will have to be exchanged for a new one.
6. Electric operation. . burnt out winding in heater, see item 15 a.
7. 12 V operation. . voltage drop due to defective battery, or wiring from battery to the refrigerator not heavy enough. . see item 4 b.

Note:

TAKING OUT THE REFRIGERATOR.

1. Disconnect the gas and electrical connections of the refrigerator.
2. Unscrew the two screws of the door frame of the furniture, take out the frame with the whole door. Unscrew the screws of the refrigerator (two screws each) at the side of the furniture.



... the refrigerator people

3. The cover, which is fixed with 3 screws, of the flue vent housing in the wall has to be taken off, then unscrew the 2 screws of the aluminium flange. Now you can take out your refrigerator.

4. When reinstalling, proceed in the opposite way. Please pay attention that the joint between the flange and the van wall is fitted correctly. If any gasket is damaged please contact immediately the distributor service.

5. After reinstalling, check the gas connection for leaks as in item 14 d.

All the above instructions are to be followed closely. This refrigerator is quality guaranteed, however, we are not responsible for any failures caused by improper adjustments and unfavorable installation conditions. Contact service point or distributor service department for assistance if required.

17. Spare parts.

All spare parts as burner, heating element, thermostat and so on are available at your service center. The address of the service center next to you can be found in the added booklet „Factory Authorized Service Centers For Dometic Refrigerators“.

