

VOLKSWAGEN

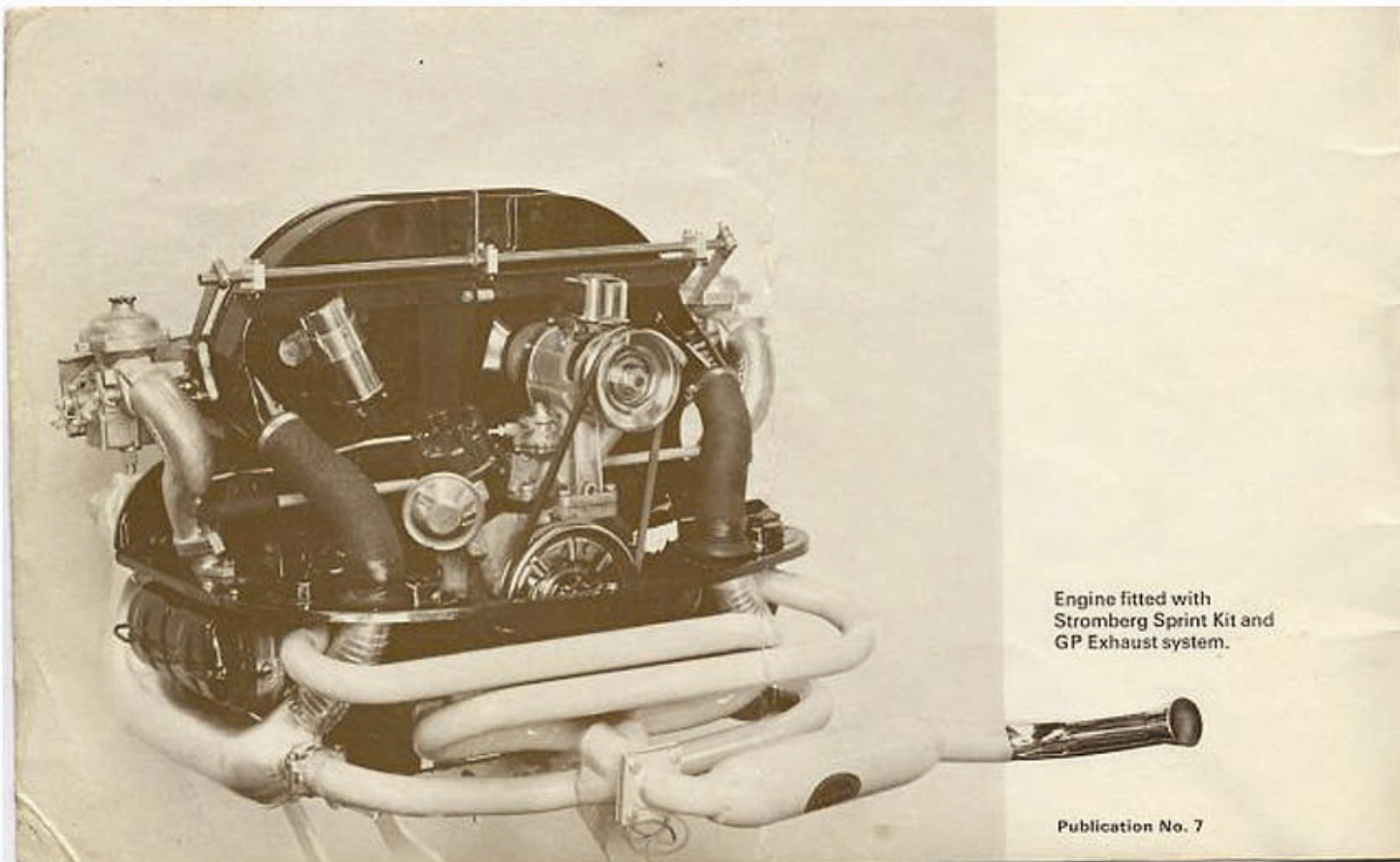

**special
equipment
for your
motor car**



Engine fitted with
Stromberg Sprint Kit and
GP Exhaust system.

Publication No. 7

Speedwell-EMPI Equipment will make your Volkswagen an even better Car

Speedwell products will help you modify your VW to suit your precise personal requirements, whether you want extra acceleration, higher cruising speed, better instrumentation, improved road holding and braking or other individual touches, Speedwell and EMPI produce and supply the best equipment for the job.

Performance Equipment

You can improve the performance of your engine in small easy stages or in one or two big steps, as all Speedwell and EMPI items can be purchased separately or as complete kits, which of course have a slight price advantage. All engine kits are developed in Speedwell's own Engine Test House which is one of the most elaborate and scientifically equipped test centres in the country. The specifications derived from these engine tests, ensure that when a kit is fitted to your engine it will give you a consistent and pre-determined performance. Speedwell's team of skilled technical staff, under the leadership of our Technical Director, D. W. H. Jones, ensure that our products are manufactured to the highest engineering standards, yet remain competitively priced to suit everyone's pocket.

When contemplating engine improvements, the VW owner will usually consider fitting a larger carburettor or twin carburettors. Speedwell offer a Sprint or Sport Kit giving the enthusiastic Volkswagen driver the choice of either. An alternative method available for the 1200cc VW is to increase the capacity to 1350cc. The Sprint Kits and Big Bore Kits are combined into a complete specification as a GT Kit.

For further improvements, there is a complete range of Grand Prix Exhaust Systems, which will be followed throughout 1966 by further items such as camshafts, rockers, big bore kits for the 1300cc etc. For the first time ever the VW owner is able to purchase the world

famous EMPI Line of Volkswagen equipment as well as new developments from Speedwell.

Road Holding and Braking

Whether your VW is standard or modified, better road holding and braking can only add to the safety factor. The front stabiliser and Rear Camber Compensator produced by Speedwell for the VW Range is another exclusive EMPI product developed after exhaustive track tests in America—thousands are already in use in England and the Continent. The simplest method of improving braking power is by applying more pedal pressure. The fitting of the Brake Servo will in fact produce this higher pressure without increasing pedal effort.

Instrumentation and Accessories

Your car is not complete without a full complement of instruments to tell you exactly what your engine is doing. Speedwell gauges are unsurpassed for their quality and attractive appearance. All Speedwell and EMPI accessories have a useful function either by rectifying a shortcoming in the original design or by improving existing features and are designed to increase your motoring pleasure.

Speedwell Manual and Order Procedure

For further details of our equipment featured in this leaflet and the complete range of Speedwell equipment plus tuning hints etc., you need the Speedwell Manual, a book about safe and faster motoring which is priced at 8/6d. An order card is attached to the back cover of this pamphlet. Speedwell equipment is available from your nearest accessory shop, garage or Halfords branch. If in difficulty we would be pleased to supply the name and address of your nearest stockist.

CARBURETTOR KITS

Sprint Kit

With Twin Strombergs

Over the years many twin carburettor devices have been offered for the VW. All of them have suffered from severe limitations. They usually comprised small fixed choke carburettors and each time there was a change in the engine specification, for example, capacity increase, one would require new carburettors and manifolding. Secondly results were usually disappointing, in addition throttle action was often poor and installation involved accurate marking-out, drilling or welding. The Speedwell Sprint Kit introduces a complete fresh approach to this problem by using two Stromberg CD Constant Vacuum Carburettors of $1\frac{1}{2}$ " (38mm) bore. Only this type of carburettor can give good operation over a wide range of engine size and power. They present a choke area of over four times the standard carburettor and can deal with engine outputs of up to 100 HP for future conversions. At the other end of the scale these remarkable units give good carburation even to the 1200 engine, raising its power output from 34 to 40 bhp (DIN) without any other changes.

Inlet Manifolding

Since the introduction of the 34 HP 1200 engine there have been quite a number of changes to the inlet port design of the cylinder heads. To make it possible to fit the Speedwell Inlet Manifolds to the various types of cylinder heads, Speedwell have developed a series of adaptors bolted to the manifolds with an O-ring seal. These are therefore the only components which have to be changed to transfer the carburettor set from one engine to another. A 1200 Volkswagen owner can therefore happily fit the Speedwell Sprint Kit to his car, in the knowledge, that by a very small additional outlay, he can transfer his kit to the 1300 Volkswagen without any difficulty. The manifolds are connected to each other by a balance pipe, with

rubber hose joints, making the connection of vacuum gauges, brake servos etc., an easy matter.

Carburettor Linkage

The entire linkage mechanism takes up existing bolt holes in the engine fan housing. There is therefore no measuring, marking, drilling or cutting to be done. The linkage crossshaft $\frac{1}{2}$ " in diameter for torsional stiffness, does not rely on the fan housing for strength, it is carried in three massive bearings on a rigid cross-member. To ensure the minimum of interference with the very satisfactory throttle pedal mechanism, the cable guide, return spring etc., remain unchanged in their original position, picking up the lower end of the Speedwell Rocking Lever. The mechanism is adjustable to give the choice of three different pedal travels by fitting a link in one of three holes. This gives a normal, extra-progressive or extra-quick accelerator action to the driver's individual preference.

Carburettor Adjustment

A simple setting up procedure enables the twin carburettors to be accurately synchronised. Quick rough adjustment is obtained by clamps holding the levers to their shaft. Final delicate adjustment is offered by the micrometer action of the left and right hand threads in the nylon ball-joint links. Slow and fast idle stops are provided on the carburettors themselves.

Air Cleaners

Efficient pancake air cleaners are provided and a cross-structure between the carburettors combines to give both strength to the whole assembly and provides a mounting position for an auxiliary oilcooler radiator if required.

Sound Engineering

This new Speedwell Sprint Kit is the first properly engineered twin carburettor conversion for the Volkswagen and it will give you many hours of pleasurable performance motoring.

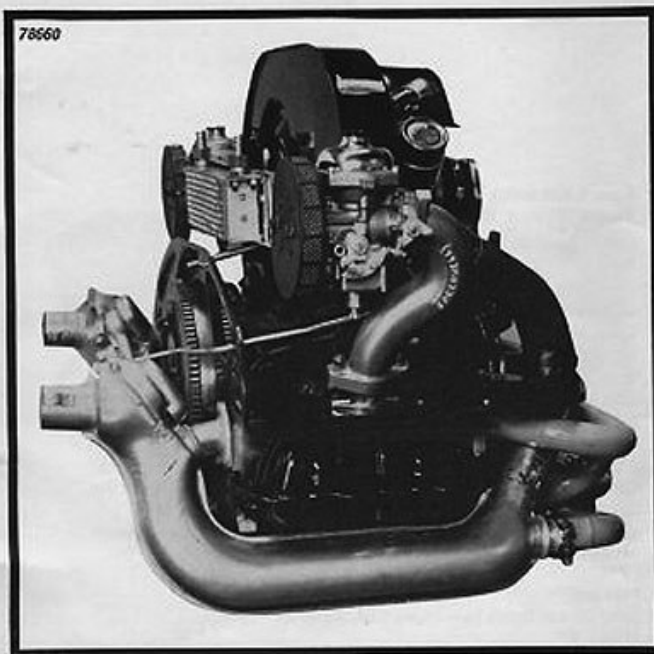

Sprint Kit for 36 and 40 HP 1200 and 1300 VW

A complete kit for converting your Volkswagen engine to twin carburetors to give you that all essential edge on standard performance figures. This Stromberg Sprint Kit includes Twin $1\frac{1}{2}$ " Stromberg Carburetors complete with connecting Cross-Shaft Assembly, Linkages, Fuel Line Kit, Choke Cable, Polished Inlet Manifolds with Port Adaptors, Carburettor Support Brackets with integral Oil cooler Mount*, all necessary nuts and bolts and full fitting instructions for easy fitting.

Part No.

Sprint Kit for 36 HP 1200VW

Sprint Kit for 40 HP 1200VW

Sprint Kit for 1300 VW

*Oil cooler not included

CAS.700

CAS.700/1

CAS.710

PRICE £39.15.0

For further improvement fit Big Bore Kit CY.500 (1200 VW's only) and/or Grand Prix Exhaust System (see pages 5 to 9).

ENGINE SPORT KITS

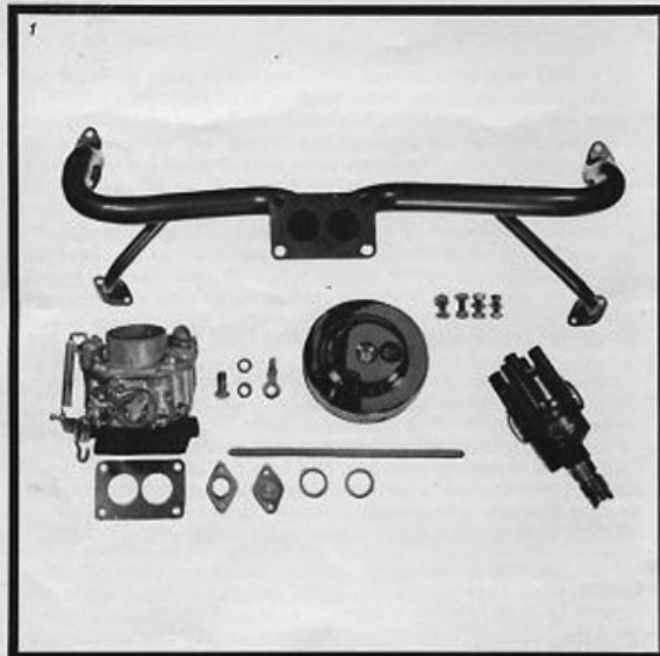

Sport Kit with Ram Induction and Zenith Twin Choke Carburettor

For 1200cc VW and 1500 Combi and Truck

The Speedwell-EMPI Induction Kit produces higher torque and smoother operation from idle speed to full throttle. Output is raised by approximately 15%. The ram designed tubular inlet manifold provides low resistance paths between the cylinder heads and carburettor. Each inlet port is fed by one half of the dual throat carburettor. For quicker warm-up a manifold heater pipe is used as on the original set-up. The specification includes, special Inlet Manifold in stove enamelled finish, Zenith Twin Choke Carburettor, Free Flow Chrome Plated Air Filter, Centrifugal Advance Distributor for correct timing of the larger speed range obtainable, all necessary Gaskets, nuts and bolts and complete instructions for easy installation.

Part No.

Sport Kit with Zenith Twin Choke Carb. for 40 HP 1200cc VW

Sport Kit with Zenith Twin Choke Carb. for 1500 Truck range

SA.50

SA.50.T

PRICE £58.0.0

For further improvement fit Big Bore Kit CY.500 and/or Grand Prix Exhaust System (see pages 5 to 9).

**Big Bore Kit for 1200cc VW**

This is a simple quick way to get more power for a reasonable outlay. Increases capacity to 1352cc. Fits all VW 40 HP engines with original crankshaft. New improved piston and ring design assures superior engine compression and minimum oil consumption. The kit includes, four matched 82mm high performance Cylinders with four Alloy Pistons, each with hand gapped Rings and steel alloy Gudgeon Pins.

Part No.
Big Bore Kit for 1200 VW

CY.500
PRICE £42.0.0

For further improvement fit Sprint or Sport Kit and/or GP Exhaust System.

ENGINE GT KITS

**GT Kit for 1200cc VW 40 BHP**

With Zenith or Stromberg Carburettors

These kits combine the components from the Twin Stromberg Sprint Kit plus the Big Bore Cylinders and Pistons. As an alternative specification the Big Bore kit is combined with the Ram Induction Manifold and Twin Choke Zenith Carburettor. By combining all the components of these two alternative specifications the VW owner will find an obvious price advantage.

Part No.
GT Kit with Twin Strombergs for 1200 VW

GT.A.50
PRICE £79.15.0

GT Kit with Zenith Twin Choke Carburettor for 1200 VW

GT.A.51
PRICE £97.10.0

For further improvement fit GP Exhaust System.

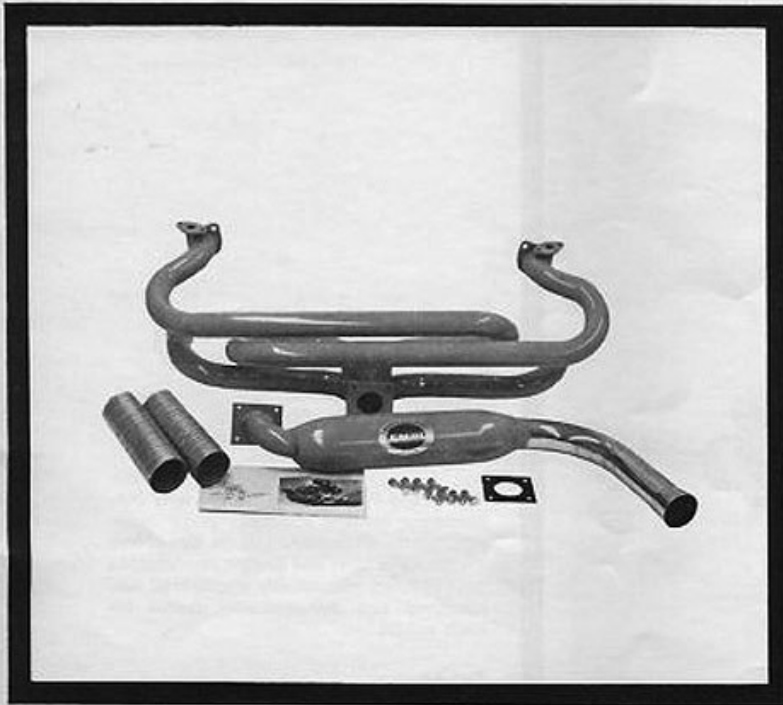

Grand Prix System for VW 1200

Complete exhaust system; a combined Tubular, tuned multi pipe lengths, manifold and straight-through silencer, does not interfere with heating system, yields ultimate power output.

Part No.

Volkswagen 1200 36 bhp.	XS.50
Volkswagen 1200 40 bhp. 1961	XS.50/1
Volkswagen 1200 40 bhp. 1963 - 65	XS.50/2
V.W. Karmann Ghia 40 bhp.	
Fresh Air Heater	XS.50.K/1
V.W. Karmann Ghia 40 bhp. pre	
Fresh Air Heater	XS.50.K

PRICE £29.19.6

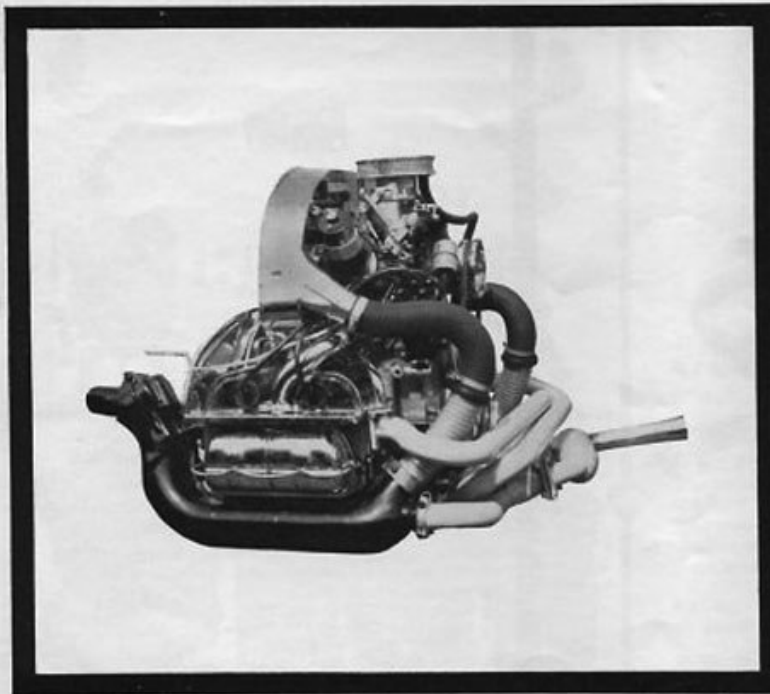

Grand Prix system for VW Truck & Combi.

The Grand Prix systems are the only performance exhaust extractor units available for the Volkswagen range. Speedwell are proud to offer this unique performance modification. Individually engineered and designed and dynamometer tested for each model.

Part No.

Volkswagen 200 series Trucks and Combi with 1500 engine	XS.50.T
---	---------

PRICE £29.19.6



Grand Prix system for Porsche.

Complete system for all push rod Porsche models. Release that hidden power with a cooler running engine. For competition purposes a "stinger" pipe is quickly fitted in place of the silencer unit. This option is available for all GP exhaust systems for VW range.

Part No.
Porsche all models with push rod engines XS.59
PRICE £34.19.6

VALVE GEAR

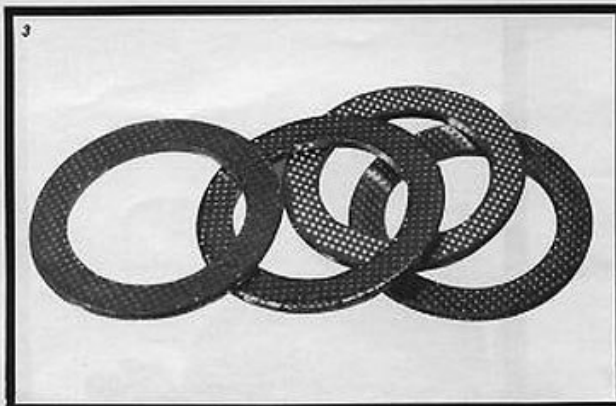

Valve Spring Spacers

These spacers are a must on every valve job. When valves and valve seats are re-faced the stems are lengthened enough to effect valve spring tension. This lost tension can be replaced by the valve spring spacers restoring original performance. If you want just 200 more rpm out of your engine add the valve spring spacers to a set of new valves and springs. The spacers will also act as an insulator between the spring and the hot cylinder head, minimising the deterioration rate of the spring.

Part No.
Set of Valve Spring Spacers for 36 HP engine VA.220 PRICE
Set of Valve Spring Spacers for 40 HP engine VA.221 19/6d.

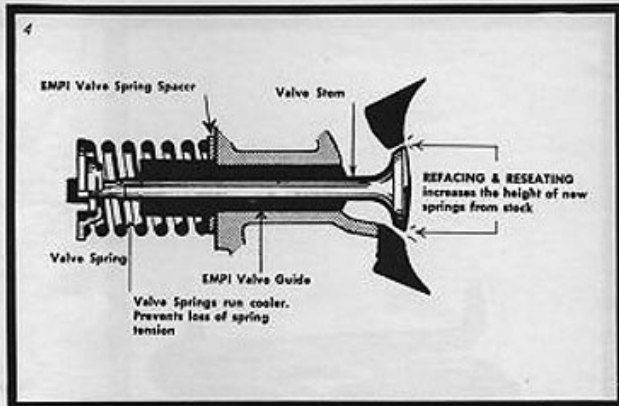

Silicon Bronze Valve Guides

EMPI pioneered the aluminium silicon bronze replacement guide for the VW. If you are having a head overhauled and the valve guides are worn then you can do no better than specify these aircraft quality valve guides. Resistant to acid and oxidation at high temperatures. Guaranteed superior to the original equipment.

Valve Guide Tool Kit

This is a special Valve Guide Tool Kit enabling the old valve guides to be removed quickly without heating or any other complicated measures.

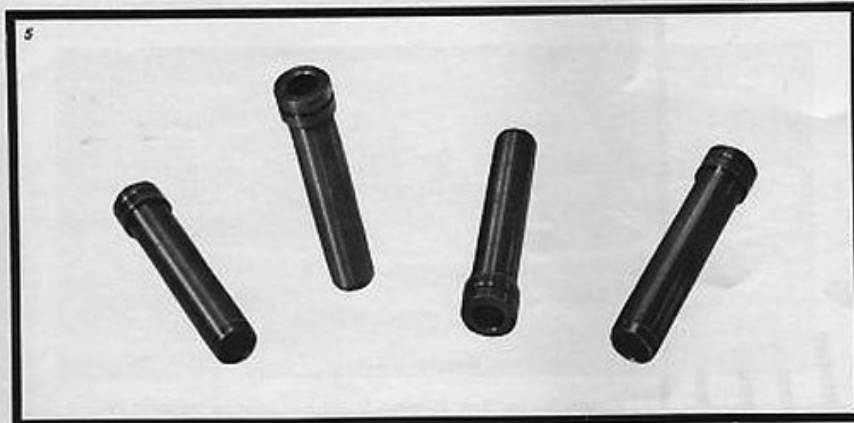

Valve Guides Standard Size

Part No.	Exhaust	Inlet	PRICE
36 HP VW	CHP.50	CHP.60	14/0d. each
40 HP and all 1500's	CHP.51	CHP.61	14/0d. each
Porsche	CHP.52	CHP.62	£1.1.6 each

Valve Guides Oversize (Plus .005" OD)

Part No.	Exhaust	Inlet	PRICE
36 HP VW	CHP.53	CHP.63	£1.1.6 each
40 HP VW and all 1500's	CHP.54	CHP.64	14/0d. each
Porsche	CHP.55	CHP.65	14/0d. each
Valve Guide Tool Kit		TO.60	£13.10.0



Rocker Arm Support Kit

Loose Rocker Arm Support Studs can now be repaired in 45 minutes per head without removing the engine from the car. Most methods devised to date for remedying the problem of worn support stud threads lead to an expensive repair job because of high labour charges and/or costly replacement parts. This ingenious new EMPI method is inexpensive and certainly time saving. With the special kit new snug fitting threaded steel sleeves replace the worn aluminium threads that mount the rocker arm support studs. Usually when the studs start to wear they quickly enlarge the threaded hole in the head, the rocker stud kit is therefore supplied with oversize studs.

Part No.	PRICE
Oversize Rocker Stud Kit	VA.210 £5.19.6
Oversize Rocker Tool Kit	TO.210 £5.5.0

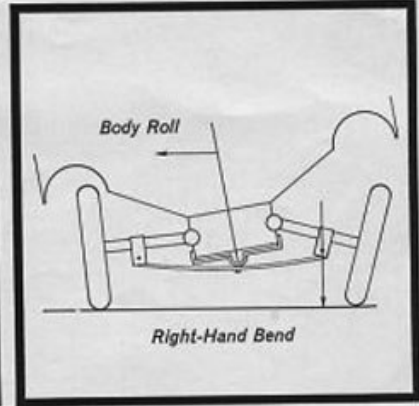
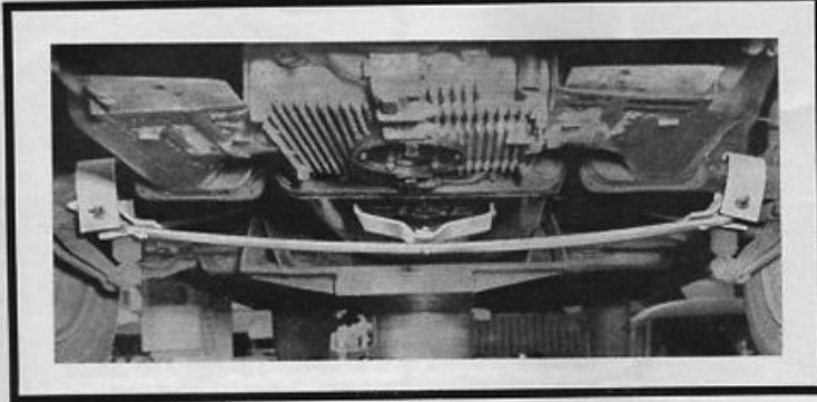

Camber Compensator

The Speedwell Camber Compensator fitted to the rear suspension reduces body-roll, prevents wheel lifting and improves steering response. Under extreme cornering conditions transion into a slide is smooth and the tendency for the wheels to hop and tuck under is reduced. The problem of weight transfer is apparent in all motorcars whether they have rigid or independent rear suspension. This uausly takes the form of lifting of the rear wheel with consequent loss of stability. In the case of the swing axle rear suspension as fitted to the Volkswagen, the resulting sideways hopping causes tucking under of the outside wheel, seriously reducing control. Available for all current Volkswagen models.

Part No.	
For Volkswagen 57-60 up to Chassis No. 1726005	RC.50
For Volkswagen 1960 up to Chassis No. 3193506	RC.50/1
For Volkswagen 1200 and 1300, 1500 and 1600 TL and Variant (Not suitable for Variant fitted with Helper Springs)	RC.50/2
	PRICE £7.0.0

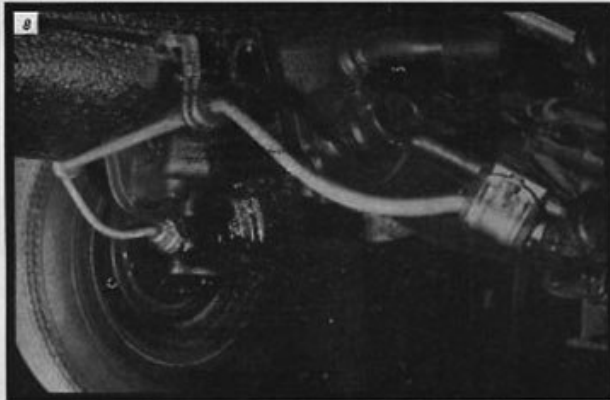

Front Stabilizer

The Speedwell-EMPI Front Stabilizer is suitable for all 1200VW's and all Trucks, Combi and Station Wagons from 1955-1966. After 1961 the VW has come equipped with a very light front stabilizer and for these cars we offer a heavy duty replacement which will further improve road holding characteristics. The main function of the stabilizer is to reduce body-roll and improve cornering power. Under all conditions the stabilizer is ideal for faster cornering giving the car delicate control under difficult conditions. It does not affect your ride comfort but gives additional security and high speed stability, especially in cross-winds. Supplied complete with all nuts and bolts ready for easy installation. The stabilizer kit for the Trucks and Caravans will be of particular interest to all VW owners who use these vehicles for long distance holiday motoring and business purposes. A heavy duty racing stabilizer is available for the VW Saloon, but this is not recommended for ordinary road use.

Part No.		
Front Stabilizer Bar for direct replacement of original part	AR.50	PRICE £7.15.0
Front Stabilizer Bar for all Trucks, Combi and Station Wagons	AR.50.T	PRICE £8.10.0
Front Stabilizer Bar for Competition version	AR.50/R	PRICE £9.10.0



Telescopic Shock Absorbers

Heavy duty Telescopic Shock Absorbers will give you further improvement in general stability and road holding. Keep those wheels on the ground by fitting the Speedwell-EMPI VW Shock Absorbers.

Part No.

Telescopic Shock Absorber Rear for 1200 and 1300 VW	TSR.A50	PRICE £2.15.0
Telescopic Shock Absorber Front for VW 1200	TSF.A50	PRICE £2.15.0
Telescopic Shock Absorber Front for 1300VW	TSF.A51	PRICE £2.15.0

Steering Damper

This is a most vital part in maintaining good steering stability. The Speedwell-EMPI Damper is a heavy duty telescopic type of extremely robust construction incorporating oil flow control valves. Fits all Volkswagen Saloons from 1961 onwards.

Part No.

Steering Damper	TSD.A50	PRICE £2.10.0
-----------------	---------	---------------

ROAD WHEELS



Part No.
Speedwell BRM Magnesium Road Wheel

RWM.A50
PRICE £28.10.0 per pair

Speedwell-BRM Magnesium Wheels

Stronger than Steel

Unbelievable but true—Magnesium is quarter the weight of steel, therefore it can be used in thicker section, i.e. by replacing a steel section by one of magnesium twice as thick the mag piece will be 70% stiffer, have 50% more tensile strength and half the weight! Only magnesium has these properties—aluminium alloys are only half as stiff on an equal weight basis.

The Speedwell-BRM wheel is a real magnesium road wheel designed to have enormous strength and more than twice the rigidity than the steel wheel with a 40% reduction in weight. On a wheel testing machine at BRM, manufacturers of the world famous racing cars, these magnesium wheels were given a rotating load equivalent to continuous .6G cornering. Steel wheels broke up at 3 million reversals—the Speedwell-BRM wheel was unbroken at 15 million reversals.

Technical Specification

Rim section is 5"—Offset increased by $\frac{1}{2}$ "—Results in 2" increase in overall track. Total weight is 8 lbs as against 14 lbs for the standard wheel. Special fixing studs, bushes and chrome plated cap nuts are provided. Use 5.60 or 5.90 by 15" tyres—tubes are recommended but the wheels can also be used tubeless. Suitable for all VW and Porsche models with drum brakes and 5 stud fixing. You can now have improved road holding and braking stability by virtue of a wider track, wider tyre base, reduced unsprung weight and cooler running brakes. Get the Speedwell-BRM look on your VW to-day there is just nothing better. Supplied complete with nuts, studs, etc.—no extras. Remember it does not pay to buy cheap road wheels—fit the ones produced by experts.

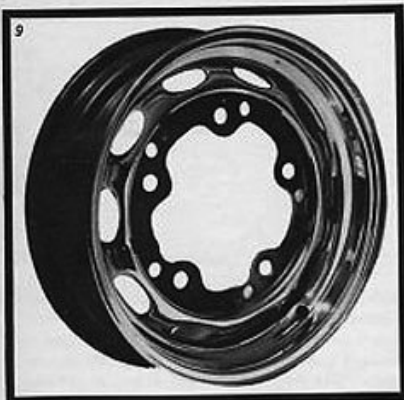

Porsche Type Off-Set Wheels

These steel wheels have a $\frac{1}{2}$ " off-set and the rim is also widened by $\frac{1}{2}$ " increasing overall tread by a full 2 inches, and minimising tyre roll on high speed turns. Completely interchangeable with standard parts. *Note.* Tyres do not touch wings. The off-set features plus the widened rims add to the safety factor and the VW owner will soon notice the improved cornering characteristics. Available chrome plated and beautifully polished or in primer paint finish.

Part No.

Off-set Steel Road Wheel in Primer

Off-set Steel Road Wheel Chromium Plated and polished

RW.50

RW.50/C

PRICE £6.10.0

PRICE £11.0.0

BRAKING EQUIPMENT

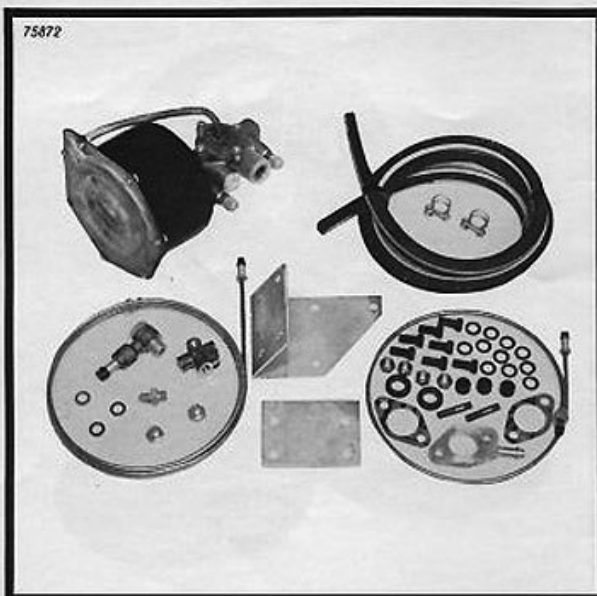

Brake Servo

The Brake Servo uses engine power to assist in the application of the brakes, reduces pedal pressure necessary for a given braking effort by 40-50%. Inlet Manifold suction is used to move a large piston driving a master cylinder similar to the one operated by the brake pedal, to provide extra pressure to the brake cylinders. This Servo kit has been specially developed by Speedwell for the Volkswagen with special mounting brackets for fitting the Servo unit underneath the rear seat inside the car, complete with all necessary parts and special inlet manifold adaptor.

Part No.

Brake Servo Kit for 1200 and 1300 VW BKS.A50

PRICE £14.15.0

Electronic Revcounter

Fully Transistorised Tachometer from 0-8,000 rpm, internally illuminated, supplied complete with universal mounting bracket, connecting cable and full fitting instructions. A specially designed Revcounter Cowl is available which simplifies fitting to the Volkswagen and incorporates a unique swivel mount enabling the instrument to be accurately angled for maximum visibility and then locked into position with two allen screws. Black wrinkle finish. Alternatively the Revcounter can be fitted to the special instrument panels available for the VW which will be found on the following pages. Only by having correct indication of engine rpm can the driver take full advantage of the maximum performance or economy potential of his car. For the serious rally driver a Competition Tachometer is available of unequalled accuracy.

Part No.

Standard Electronic Revcounter for VW	IT.TCS4.6VW	PRICE £10.15.0
Tachometer Cowl	ITP.13	PRICE £1.19.6
Competition Revcounter	IT.TC4.6VW	PRICE £17.10.0

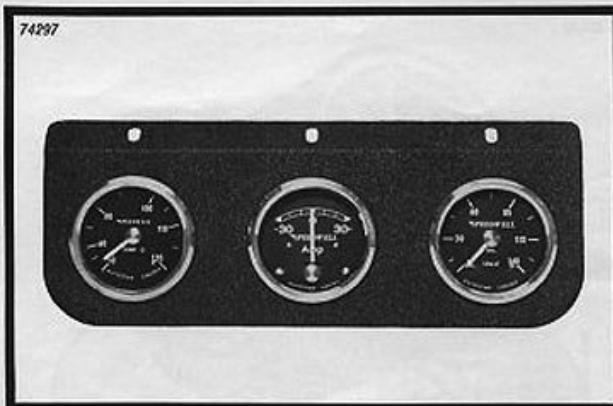

Oil Pressure and Temperature Gauges

Speedwell offer a complete range of auxiliary 2" diameter instruments for the VW owner. These can be mounted on universal mounting brackets or by utilising the special VW panels. The Oil Temperature Gauge is scaled from 60° to 140°C.

Part No.	Oil Temperature Gauge	IT.OT.6VW	PRICE £4.9.6
	Oil Pressure Gauge	IT.O.6	PRICE £3.3.0
	Ammeter	IT.A.6	PRICE £1.11.6
	'Tee' piece	IT.PA.	

Universal Mounting Brackets

Single mounting bracket	ITP.21	PRICE 5/0d.
Double mounting bracket	ITP.22	PRICE 6/6d.
Triple mounting bracket	ITP.23	PRICE 8/6d.

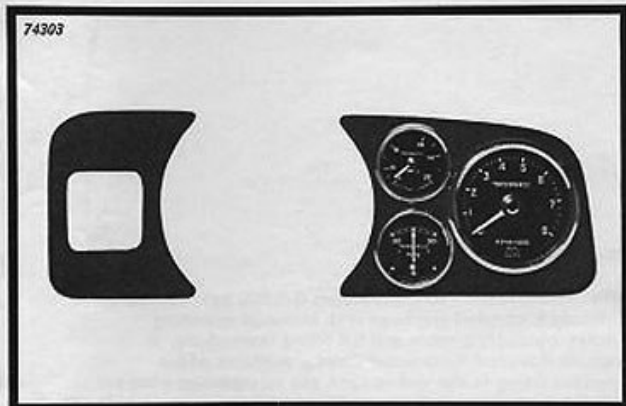

VW Instrument Panel

These VW Instrument Panels are designed to fit in place of the loudspeaker grille. Each set includes a panel for the fuel gauge. Although the fitting necessitates removing the radio loudspeaker, should one be fitted, it is more important to be able to see the gauges properly on the dashboard and it is a simple matter to find an alternative place for the speaker.

Part No.

Panel for Revcounter and two 2" instruments, RHD	ITP.50/3	PRICE
Panel for Revcounter and two 2" instruments, LHD	ITP.50/3LH	£1.7.6
Panel for Revcounter only RHD	ITP.50/1	PRICE
Panel for Revcounter only LHD	ITP.50/1LH	£1.7.6

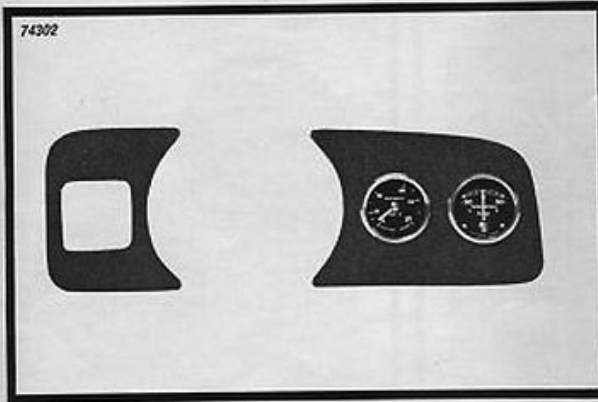

Part No.
Panel for two 2" instruments RHD
Panel for two 2" instruments LHD

ITP.50/2
ITP.50/2LH
PRICE £17.6

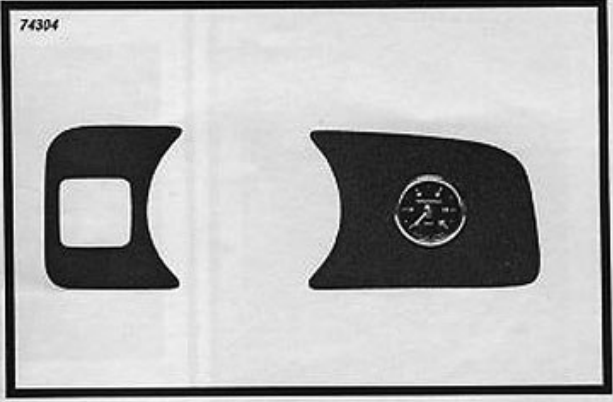

Part No.
Panel for single 2" instrument RHD
Panel for single 2" instrument LHD

ITP.50/4
ITP.50/4LH
PRICE £17.6

SPECIAL VOLKSWAGEN ACCESSORIES

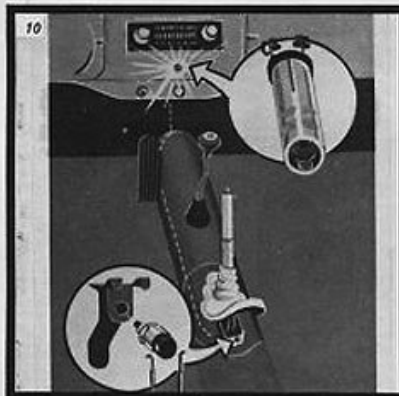

Brake Warning Light

This complete kit gives immediate warning that hand brake is on, prevents wearing out of the brakes. You will never forget to release the lever when the light flashes on as soon as ignition is switched on. Simple to instal. Complete with wire and instructions. Fits all VW's.

Part No.
Brake Warning Light AC.251
PRICE £3.15.0



Quick Shift

The Quick Shift modifies the VW's linkage mechanism to decrease by over 40% the distance the drivers arm must travel as he changes from one gear to another. Transform your VW gearbox to slick sportscar change. Suitable for all VW's, 1200, 1300, 1500, 1600 and Trucks.

Part No.
Quick Shift AC.50/7
PRICE £1.19.6

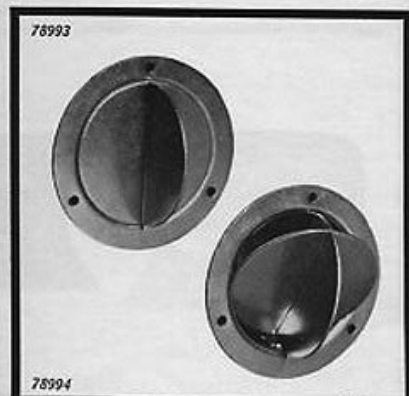

Air Vent

The Speedwell-EMPI Vent is an adjustable air shutter that regulates the flow of outside air into the VW interior. The vent is fitted to the front bulkhead to send a cooling breeze throughout the car. Easily adjusted with a touch of the toe. A deluxe version is available which enables the air to be directed towards different corners of the car.

Part No.
Air Vent AC.252
Deluxe Twin Vent AC.254
PRICE £1.12.6
PRICE £2.10.0



Coathanger

Suitable for all 1964 and 1965 models. Essential for the VW owner who uses his car for business and of course for holiday travel. Your suit can hang without risk of getting creased. Fits in the rear corner, garments do not block out rear window. The hanger is notched to keep the coathanger from sliding about. Snaps quickly into place, no tools are required.

Part No.

Rear Clothes Hanger AC.253 PRICE £2.2.0

Fan Belt Guard

Gives protection plus smart appearance. Will enhance the appearance of your engine compartment and positively prevent accidental injury. Fits all 1200 and 1300 model VW's and 1500 Transporter engines fitted with fan belts.

Part No.

AC.250 PRICE £1.19.6

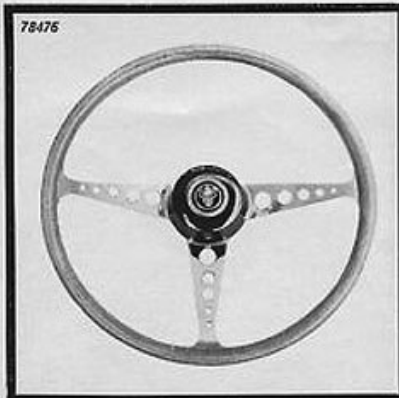
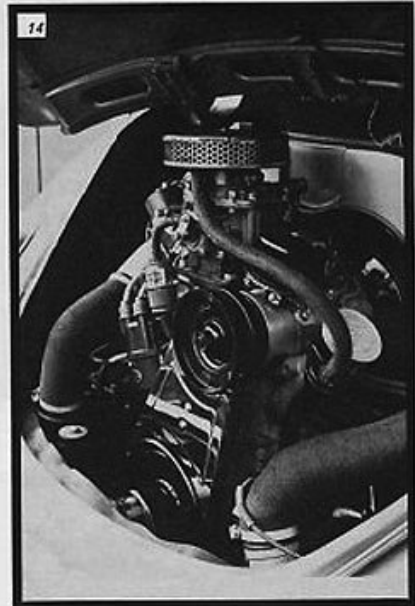

Wood Rimmed Steering Wheel

Designed for the connoisseur driver the alloy spokes are rivetted to a solid steel ring inserted in the laminated beech rim. The aluminium spokes are highly polished giving the wheel a really beautiful and attractive appearance. For those VW's fitted with horn rings as standard equipment, the horn button from the earlier models has to be fitted.

Part No.

Steering Wheel for VW SW3.A50 PRICE £8.19.6
Horn Button SWB.A50 PRICE 15/0d.

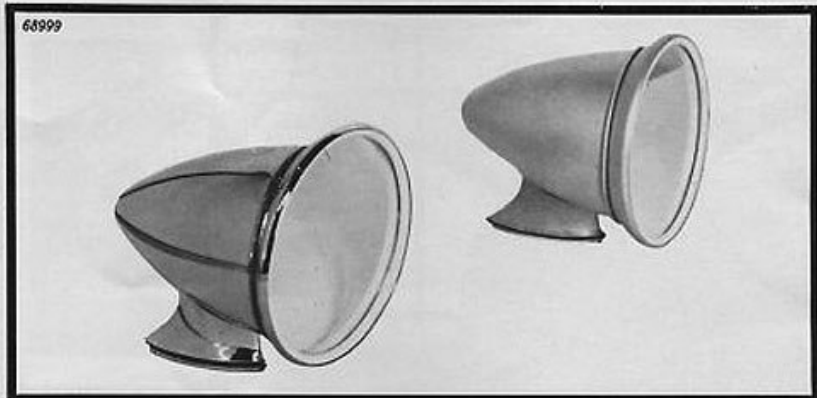

Race and Speed Mirrors

Two types of streamlined rear view mirrors are available. Speed Mirrors are made from a brass pressing, heavily chrome plated, whilst the Race Mirror is manufactured from Aluminium with polished anodised finish. Fully adjustable head makes these mirrors easy to position. Available with flat or convex glass.

Part No.

Speed Mirror with flat glass AC.51.F
Speed Mirror with convex glass AC.51

Race Mirror with flat glass
Race Mirror with convex glass

AC.52F
AC.52
PRICE £1.10.0

**Horns**

Two types of horns specially suitable for the VW are the TR2 Major which gives a tuned sharp melodious blast and the Strident Air Horn a very compact but powerful twin trumpet horn. A relay must be used with the TR2 Horns and is available as an extra.

Part No.			
T.R.2 Major, 6 volt.	AC.TR2.6	PRICE £3.19.6	per pair
Strident Air Horn 6 volt	AC.10.6	PRICE £6.19.6	
with relay	AC.36	PRICE 12/6d.	
Relay 6/12 volt			

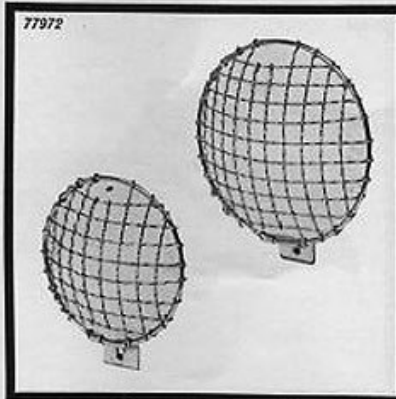
**Lamp Stoneguards**

Essential for all Rally Drivers where there is a risk of flying stones. These chrome plated stoneguards are available for both headlamps and auxiliary lights.

Part No.		
For VW headlamps	AC.53VW	
For 5" Spotlight	AC.54/5	PRICE 17/6d. each
For 6" Spotlight	AC.54/6	PRICE 17/6d. each

**Roof Lamp**

This roof spotlight gives 360° visibility enabling the motorist and rallyist to quickly locate road signs, turnings under all conditions. On and Off switch incorporated in the handle which projects 4½" into the car. Supplied complete with bulb.

Part No.	AC.50.6	PRICE £7.19.6
-----------------	---------	---------------

PERSONAL ACCESSORIES

**Graham Hill Rally Master Jacket**

Specially designed by Graham Hill for the discerning driver. This Rally Master Jacket is waterproof and windproof. With fully detachable hood, own collar, touch and close fastening, plenty of pockets. Available in various sizes and colours.

Part No.	Blue	Olive Green	Black	
Rally Master Jacket, small 36-39"	AC.71.S	AC.72.S	AC.73.S	
Rally Master Jacket, medium 38-40"	AC.71.M	AC.72.M	AC.73.M	
Rally Master Jacket, large 40-42"	AC.71.L	AC.72.L	AC.73.L	PRICE
Rally Master Jacket, ex-largo 42-44"	AC.71.LL	AC.72.LL	AC.73.LL	£10.10.0

**Graham Hill Driving Gloves**

These beautiful champion Driving Gloves are made of black soft calf leather with red finger panels, fully ventilated back with red wrist band and Velcro touch closure. Speedwell also offer a leather Rally Glove with string back available in Fawn or Black. All gloves available in small, medium or large sizes.

Graham Hill Glove			
Part No.			
Small	AC.68.S	PRICE	
Medium	AC.68.M	PRICE	
Large	AC.68.L	PRICE	£2.12.6

Rally Glove			
Part No.	Fawn	Black	
Small	AC.66.S	AC.66.BS	
Medium	AC.66.M	AC.66.BM	PRICE
Large	AC.66.L	AC.66.BL	£1.12.6

77974

**Speedwell Body Badge**

Attractively styled body badge, pressure die casting with chrome letters on black background. Easily fitted to boot.

Part No. AC.175 PRICE 7/6d.

77973

**Lapel Badges and Transfers**

Speedwell emblem in yellow on black background. The transfers are of the dry-type and are fitted in a matter of seconds.

Part No.		
Lapel badge	AC.155	PRICE 6d. each
Speedwell transfer	AC.156	PRICE 6d. each

SPECIAL ENGINE JACK

28

15

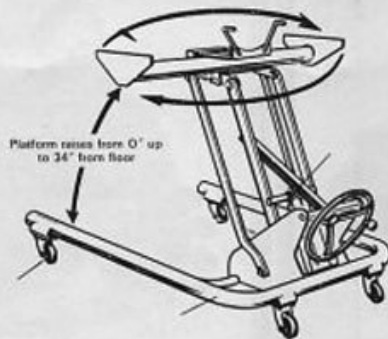
**Motor Porter**

Now one man can handle engine and transmission removal and replacement. Allows you to transport engines and transmission anywhere quickly and easily. Locks engine or transmission in place in seconds and serves as a stable and secure workstand. The Motor Porter has been tested and approved for Volkswagen workshop use. Ideal for VW Clubs, who organise their own maintenance and repairs.

Part No.
Motor Porter complete, including transmission cradle and two inter-changeable engine cradles. TO.100 PRICE £125.0.0

16

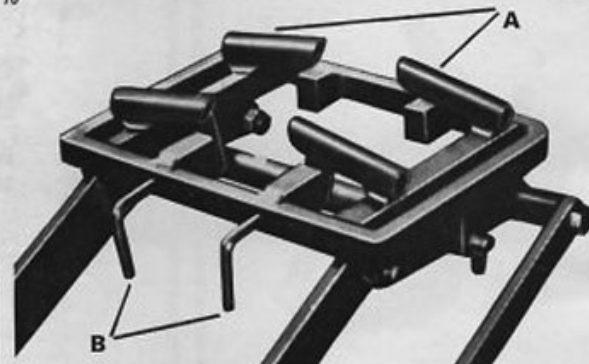
**Engine Cradle with Patented Locking Device**

Note four fingers (A) which fasten on to four nuts underneath the engine. Engine locks by pushing in locking pins, (B).

SPEEDWELL GUARANTEE

Cars . Components . Engines . Suspension

The goods supplied by Speedwell Performance Conversions Ltd., (hereinafter called the "the Company") are supplied with the following express guarantee:

- 1 For the purpose of this guarantee the term "Goods" means and includes any new Speedwell Modified Vehicle, supplied by the Company and includes replacement parts and other equipment manufactured or supplied by the Company with the exception of tyres, speedometers or electrical equipment or proprietary articles or goods (including coachwork) not of the Company's own manufacture although supplied by the Company.
- 2 For a period of 12 MONTHS from the date of which Goods are delivered to the first owner-user, the Company will exchange or repair any part which needs replacing or repair by reason of defective material or workmanship.
- 3 The Company will not be responsible

for any expense which the owner-user may incur in removing or having removed, or replacing or having replaced, any parts to be sent for inspection or in fitting or having fitted any new parts supplied in lieu thereof.

- 4 No claim for exchange or repair can be considered unless the person claiming:
 - a) Immediately upon discovery of the alleged defect returns the part or parts complained of carriage paid to the Company or the dealer from whom the parts were purchased.
 - b) Sends particulars of the Vehicle or chassis number and engine number of the Vehicle.
 - c) Sends full particulars of the claim and the reason therefor, stating in such particulars the date of purchase and name and address of the person or firm or company from whom the Goods were purchased.
- 5 No claim for exchange or repair under the terms of this guarantee may be made

in respect of:

- a) Any Goods used
 - (i) For racing, rallying and/or record attempts, or
 - (ii) For any other purpose than the private or genuine commercial use of the owner-user.
 - b) Any Goods which in the opinion of the Company have been injured by wear and tear, neglect, or any form whatsoever of improper use.
 - c) Any Goods which have been altered in any way, or to which any part not sold or approved by the Company has been affixed.
- 6 The responsibility of the Company is limited to the terms of this guarantee and it shall not be liable for personal injuries, damage, or loss arising from any defects.
- 7 The judgement of the Company in all cases of claims shall be final and conclusive and the claimant shall accept its decision on all questions as to defects and the exchange of a part.

SPEEDWELL PERFORMANCE CONVERSIONS LTD. LONDON ENGLAND



SPEEDWELL PERFORMANCE CONVERSIONS LIMITED LONDON ENGLAND

CUT HERE

Please print your name and address here

.....

.....

.....

.....

This card should be sent with your remittance to
Speedwell Performance Conversions Limited
Speedwell Centre,
Cornwall Avenue, London, N.3

PTO

CUT HERE

Please register me as a subscriber for the Speedwell News Bulletin and all future literature and information for 12 months

*Enclosed 7.5
(Pleasest 6.-)*

Please send me the new Speedwell Manual Enclosed 8/6
(6th Edition available May 1966) 6th Edition still available.



My car is

Model _____ Year _____

I am interested in the following equipment

.....

.....

PTO