



SPECIAL TOOLS

SUITED FOR REPAIR WORK ON VW CARS

AVAILABLE THROUGH YOUR REGIONAL DISTRIBUTOR

Catalog No.9 - 1969



Special TOOLS

INDEX

<u>DESCRIPTION:</u>	<u>PAGE No.</u>
US B-9 to 93	1a
US 101 to US 184	1b - 4
US 201 to US 299	5 - 13
US 307 A to US 384	14 - 16
US 400 Z to US 473	17 - 22
US 612/2 to US 699-64	23 - 25
US 705 to US 799	26 - 28
HEX KEYS,SPECIAL SOCKETS	29
SPEC,SOCKETS & US1001 to US1024 ..	30
TORQUE WRENCHES	31
EXTRACTORS,PULLERS & US1010	32
DISC BRAKE TOOLS	33
VALVE SEAT CUTTERS	34
VALVE SERVICE TOOLS	35
US 4400 to US 4434	36 - 38
HAZET SERVICE TOOLS	39
PLIERS	40
FILES,PUNCHES,CHISELS	41
HAMMERS	42
SCREW DRIVERS	43
GAGES	44
MEASURING TOOLS: CALIPERS, DEPTH GAGES,RULES	45
PRECISION MEASURING INSTRU- MENTS:MICROMETERS,BORE GAGES	46
DIAL INDICATORS	47
TAPS & DIES	48
TAP & DIE SET	49
DRILLS	50
DRILL SETS	51

<u>DESCRIPTION:</u>	<u>PAGE No.</u>
WRENCHES (#450 & #600)	52
WRENCHES (#625 & #630)	53
SOCKETS,SOCKET SETS	54
VICES	55
<u>ILLUSTRATIONS:</u>	
US B-9 to 93	56
US 101 to US 202 D	57 - 61
US 202 F to US 299	62 - 71
US 307 A to US 384	72 - 74
US 400 Z to US 473	75 - 81
US 612/2 to US 699-64	82 - 85
US 705 to US 797/3	86 - 88
HEX KEYS,SPECIAL SOCKETS	89
SPEC,SOCKETS & US1001 to US1024 ...	90
EXTRACTORS,PULLERS & US 1010	91
DISC BRAKE TOOLS	92
VALVE SERVICE TOOLS	93
VALVE SERVICE TOOLS	94
VALVE SERVICE TOOLS	95
FRAME JIG. -CHECKING TOOLS FOR AUTOMATIC TRANSMISSION ...	96
HAZET TOOLS	97
HAZET TOOLS	98
PLIERS	99
FILES,PUNCHES,CHISELS	100
MEASURING TOOLS:CALIPERS DEPTH GAGES,RULES	101
DIAL INDICATORS, EXTENSIONS	102
VICES	103

Special**TOOLS**

TOOL No.	WHGT Lbs	DESCRIPTION	TYPE				NET PRICE US \$	REMARKS
			1	2	3	4		
US B-9	0.5	RIVETING TOOL For Hub Cap Spring Clips						
US 8	0.1	MEASURING GLASS only For US 8-3						
US 8-3	0.1	MEASURING GLASS 8 cc.						
US 50	0.1	MEASURING GLASS 50 cc.						
US 80	3.0	HINGE PIN REMOVER Complete Kit.(13 Pcs)						Replacing Tool US 730
US 80-10	0.1	PRESSURE PINS 20 mm,Set of 2 Pcs.						
US 80-11	0.1	PRESSURE PINS 25 mm,Set of 2 Pcs.						
US 80-12	0.2	PRESSURE PINS 35 mm ,Set of 2 Pcs						
US 80-20	0.3	SPLIT SLEEVE						
US 80-30	0.1	PRESSURE HEAD						
V/90	10.0	PRESSURE GAGES With Connection Hose						
V/90-1	0.4	T-CONNECTION FOR V/90						
91	3.0	COMPRESSION RECORDER With 50 Pcs Diagram Charts. In Wooden Case						288 W/50
92	0.1	DIAGRAM CHARTS,50 Pcs. For Compression Recorder # 91						
93	0.5	HYDROMETER for Battery ,with Thermometer						

Special **TOOLS**

TOOL No.	WHGT Lbs	DESCRIPTION	TYPE				NET PRICE US \$	REMARKS
			1	2	3	4		
US 101	0.7	T-WRENCH,13mm, 6 points	x	x	x			
US 102	0.7	T-WRENCH,14mm, 6 points	x	x	x			
US 103	0.7	T-WRENCH,17mm, 6 points	x	x	x			
US 106	0.7	T-WRENCH,10mm, 6 points	x	x	x			
US 109	0.2	BOX WRENCH,10mm For use on Oil Cooler	x	x				
US 109 H	0.3	BOX WRENCH,10x14mm For use on Carburetor and Oil Cooler	x	x			Hazet	
US 112 A	5.30	36 mm SOCKET,6 point WITH GUIDE PLATE AND 3/4" DRIVE T-HANDLE. For loosening Flywheel Gland Nut	x	x	x			
US 113	0.8	SET OF 2 OPEN END WRENCHES,27mm For adjusting Front Wheel Bearings	x	x	x		Hazet	
US 113 A	1.0	SET OF TWO OPEN END WRENCHES,32mm For adjusting Front Wheel Bearings		x			Hazet	
US 113 B	1.2	SET OF TWO OPEN END WRENCHES,24mm For adjusting Front Wheel Bearings			x		Hazet	
US 114-1	0.3	T-WRENCH,8mm SQUARE SOCKET,300mm lg. For use on Gearshift Rod Coupling & Screws	x	x	x		US 114 discontinued Hazet	
US 121 B	0.3	PISTON RING REMOVING TOOL For Pistons from 50 to 100 mm Dia.	x	x	x		Hazet	
US 122 B	0.3	CIRCLIP PLIER For removing and installing PistonPinCirclips	x	x	x		Hazet	

Special TOOLS

TOOL No.	WHGT Lbs	DESCRIPTION	TYPE				NET PRICE US \$	REMARKS
			1	2	3	4		
US I23	0.6	PISTON RING COMPRESSING TOOL For Pistons from 75 to 76 mm Dia	x	x			Hazet	
US I23 A	0.6	PISTON RING COMPRESSING TOOL For Pistons from 77 to 78mm Dia	x	x			Hazet	
US I23 B	0.6	PISTON RING COMPRESSING TOOL For Pistons from 83 to 84 mm Dia			x		Hazet	
US I23 C	0.6	PISTON RING COMPRESSING TOOL For Pistons from 85.5 to 86.5 mm Dia			x		Hazet	
US I24	0.3	PEENING CHISEL For securing Connecting Rod Bolts and Clutch Release Lever Special Nut	x	x	x		Hazet	
US I26 A	0.4	FUEL PUMP WRENCH,14 mm For the Mounting Nuts of the Fuel Pump	x	x			Hazet	
US I26 B	0.4	FUEL PUMP WRENCH,13 mm For the Mounting Nuts of the Fuel Pump	x	x	x		Hazet	
US I30	0.5	KING PIN PILOT DRIFT Pilot Dia 5.9 mm	x					
US I30 A	0.6	KING PIN PILOT DRIFT Pilot Dia 7.9 mm	x					
US I31	1.5	KING PIN BUSHING PILOT DRIFT Pilot Dia 17.5mm.To use on Swing Lever Shaft Bushing,Sector Shaft Bushes & King Pin Bushes	x					
US I31 A	1.5	KING PIN BUSHING PILOT DRIFT Pilot Dia 21.5mm.Application same as US I31		x				
US I33	1.6	TORSION ARM LINK PIN BUSHING PILOT DRIFT,Pilot Dia 17.9mm.-For removing and installing Torsion Arm Link Pin Bushes	x					
US I33 A	1.6	TORSION ARM LINK PIN BUSHING PILOT DRIFT,Pilot Dia 19.9mm.Appl.same as US I33		x				
US I33 B	2.1	TORSION ARM LINK PIN DRIFT,Pilot Dia 26.9mm.-For removing and installing the Outer Needle Bearing Rings of TorsionArmLink Pins		x				

Special **TOOLS**

TOOL No.	WHGT Lbs	DESCRIPTION	TYPE				NET PRICE US \$	REMARKS
			1	2	3	4		
US 150	0.5	OFFSET HANDLE, 1/2" SQUARE. (With US 156) For Socket Head Screws of Front Torsion Bar	x	x				
US 151	0.3	TUBE FOR EXTRACTING. -70mm Dia. Bulletin No.: H 2.27.1967. Used with US 228 B		x				
US 156	0.1	HEX KEY, 8 mm - 1/2" DRIVE For loosening & tightening Connecting Rod Bolts, Socket Head Screws of Front Torsion Bar	x	x			Hazet	
US 157	0.2	HEX KEY, 10 mm - 1/2" DRIVE To use on Cylinder Head Nuts	x	x			Hazet	
US 159	0.6	OIL PRESSURE SWITCH WRENCH, 27mm For removing and installing the Switch.	x	x			Hazet	
US 159 A	0.6	OIL PRESSURE SWITCH WRENCH, 24mm For removing and installing the switch.	x	x	x		Hazet	
US 161 A	0.7	CIRCLIP PLIER Removing and installing Circlip on Drive Pinion, on Hand Brake Lever Pin, Etc.	x	x	x		Hazet	
US 161 B	0.2	SET OF SPARE JAWS WITH PINS & SCREWS FOR US 161 A 2 pcs Jaws, 1 Pin, 1 Screw	x	x	x		Hazet	
US 162	0.3	SOCKET, 32mm, 1/2" DRIVE, 6 POINT	x	x	x		Hazet	
US 163 A	0.5	SOCKET, 36mm, 3/4" DRIVE, 6 POINT For loosening rear Axle Shaft Nut	x	x			Hazet	
		OTHER SOCKETS SEE ON PAGE: 29-30 & 54						
US 165	0.3	SOCKET WRENCH 15 mm, 1/2" DRIVE For loosening & tightening Cylinder Head Nuts	x	x	x		Hazet	
US 170	0.2	SOCKET, MODIFIED AS PER BULLETIN M24 For loosening & Tightening Threaded Ring in Oil Filler and in Oil Breather	x	x	x			
US 171	0.02	SPRING CLIPS, -SET OF TWO For holding the Cam Followers	x	x	x			

Special **TOOLS**

TOOL No.	WHGT Lbs	DESCRIPTION	TYPE				NET PRICE US \$	REMARKS
			1	2	3	4		
US 172	0.4	DRAIN PLUG KEY, 17mm HEX SOCKET For loosening & tightening the Oil Drain Plug In Transmission Case	x	x	x			
US 172 H	0.5	SPECIAL WRENCH FOR OIL SERVICE 17mm HEX & 21mm BOX END.-For the Oil Drain Plugs in Transmission Case ,Etc.	x	x	x		Hazet	
US 173	0.3	SPECIAL SOCKET, 1/2" DRIVE FOR SAXOMAT AUTOMATIC CLUTCH.Used on Gland Nut	x					
US 174	0.1	SPECIAL SOCKET, 1/2" DRIVE FOR SAXOMAT AUTOMATIC CLUTCH.Used on SOCKET HEAD	x					
US 176	0.9	EXTRACTOR FOR FAN For extracting the Fan from Crankshaft			x			
US 177	1.6	CENTERING SLEEVE FOR FAN HOUSING For centering the front half of the Fan Housing to the Oil Return Thread.			x			
US 178	0.3	SPECIAL WRENCH FOR CARBURETOR For removing & tightening the Carburetor Mounting Nuts			x			
US 179	0.4	SPECIAL WRENCH 36 mm For adjusting the Camber by resetting the eccentric Bush on Upper Torsion Arm	x					
US 180	0.7	OPEN END WRENCH, 46mm To use on the Threaded Adaptor for the Heat Exchanger on the Muffler			x			
US 181	0.6	OPEN END WRENCH ,42mm. For holding the Bolt of the Rubber Stop on the on the Front Shock Absorber	x					
US 182	1.0	SPECIAL TWO-PIN WRENCH FOR AUTOMAT. TRANSMISSION.For adjusting the Ring Gear and the Preload of the Pinion Bearing			x			
US 183	1.0	C-WRENCH FOR ROUND NUT FOR AUTO- MATIC TRANSMISSION .To use on the Nut of the Double Tapered Roller Bearing	x					
US 184	5.5	RETAINER FOR THE DRIVE PLATE OF AUTO- MATIC TRANSMISSION. For holding the Torque Converter Drive Plate	x		x			

**Special TOOLS**

TOOL No.	WHGT Lbs	DESCRIPTION	TYPE				NET PRICE US \$	REMARKS
			1	2	3	4		
US 201	0.8	OIL PUMP EXTRACTOR For extracting the Oil Pump Body	x	x	x			
US 202	3.6	EXTRACTOR FOR USE WITH US202A to 202T For various removal operations.	x	x	x			
US 202 A	0.8	EXTRACTOR HOOKS (SET OF TWO) For removing the Crankshaft Gears	x	x	x			
US 202 BZ		EXTRACTOR-COMplete UNIT For removing the Brake Drums & Brake Discs. Latest type.	x	x	x		US 202 C discontinued	
US 202 D	0.8	EXTRACTOR HOOKS (SET OF TWO) For removing the Steering Drop Arm, the Reduc- tion Gear Case and the Steering Wheel.	x	x	x			
US 202 F	0.3	THRUST PAD For removing the Gears from Krankshaft, For extracting Inner Ball Bearing	x	x	x			
US 202 I	0.3	THRUST PAD For removing Front Brake Drums and Spacer of Inner front Wheel Bearing	x					
US 202 K	0.2	THRUST PAD For removing the Reduction Driven Gear and Shaft outer and inner Bearings.		x				
US 202 M	0.3	THRUST PAD For removing the Front Brake Drums and Spacer of the inner Front Wheel Bearing		x				
US 202 P	4.0	EXTRACTOR PLATES For removing the Steering Wheel from the Steering Column.		x				
US 202 S	1.0	EXTRACTOR HOOKS (SET OF TWO) For removing the Spacer of the Inner Front Wheel Bearing	x	x				
US 202 T	0.1	THRUST PAD For removing the Front Brake Drums			x			
US 202 U	1.8	EXTRACTOR HOOKS (SET OF TWO) For pulling off the Roller Bearing from the Reduction Gear ,Driven Gear and Shaft		x				

**Special TOOLS**

TOOL No.	WHGT Lbs	DESCRIPTION	TYPE				NET PRICE US \$	REMARKS
			1	2	3	4		
US 203 B	0.8	FAN PULLEY EXTRACTOR For removing Crankshaft Pulley with Engine removed or in situ.	x	x				
US 203 B-6	0.3	REPLACEMENT HOOKS (SET OF TWO) For use on US 203 B	x	x				
US 203 D	0.4	FAN PULLEY THRUST PAD For removing the Crankshaft Pulley	x	x			Used with US 203 B	
US 204 B	2.0	CRANKSHAFT OIL SEAL INSTALLING TOOL For installing the Crankshaft Oil Seal	x	x	x			
US 207	1.2	PISTON PIN PILOT DRIFT For removing or installing the Piston Pin after having heated the Piston	x	x	x			
US 207-I	1.3	PISTON PIN PILOT DRIFT-NEW MODEL For removing or installing the Piston Pin after having heated the Piston(1500 & 1600 cm ³	x	x	x			
US 207 B	4.0	PISTON PIN REMOVING AND INSTALLING TOOL.For removing & installing the Piston Pin after having heated the Piston	x	x	x			
US 212 A	0.4	PISTON PIN BUSHING REMOVING AND INSTALLING TOOL.For removing and installing the Piston Pin Bushing	x	x				
US 214 D	20.0	CONNECTING ROD REPAIR DEVICE. For checking & straightening removed connecting Rods ,checking parallelism.214B&C comb.	x	x	x		Price incl. the tool in wooden box	
US 215	0.3	FLYWHEEL RETAINER IN CONNECTION WITH US 307.For holding the Flywheel when loosening and tightening the Gland Nut.	x	x	x		Used with with old Mod. 2 arm Fixt.	
US 215 B	0.5	FLYWHEEL RETAINER For holding the Flywheel when loosening and tightening the Gland Nut	x	x	x			
US 215 C	0.4	FLYWHEEL RETAINER FOR 130 TOOTH FLYWHEEL.For holding the Flywheel when loosening and tightening the Gland Nut	x	x	x			
US 217	1.3	FACING CUTTER WITH PILOT. For refacing the Torsion Arm Eyes					Guide Dia 18 mm	
US 217 A	0.2	FACING CUTTER PILOT.For refacing the Torsion Arm Eyes in conjunction of the Cutter.		x			Guide Dia 20 mm	
US 217 Z	0.2	FACING CUTTER -Replacement To use on US 217	x	x			Before US 217 B	

Special TOOLS

TOOL No.	WHGT Lbs	DESCRIPTION	TYPE				NET PRICE US \$	REMARKS
			1	2	3	4		
US 219	1.0	CLUTCH PILOT For centering the Clutch Plate during Installation of Clutch Assembly	x	x	x			
US 219 A	1.0	CLUTCH PILOT WITH 12mm GUIDE FOR AUT. CLUTCH. For centering the Clutch Plate during installation of Clutch assembly	x					
US 222 A	0.3	STARTER SHAFT BUSHING PILOT DRIFT For removing & installing the Starter Shaft Bushing in Transmission Case (Both Sizes)	x	x	x		Replacing US 222	
US 224	1.1	KING PIN BUSHING REAMER, 18 to 21 mm For reaming up the King Pin Bushes. Reamer with two Guides, 35mm long.	x					
US 224-1	0.2	SET OF 5 BLADES. Replacement for Reamer 18 to 21 mm	x					
US 224-2	0.2	LOCK NUTS (SET OF TWO) For Reamer 18 to 21 mm	x					
US 224 A	1.6	KING PIN BUSHING REAMER, 21 to 24.5 mm For reaming up the King Pin Bushes and the Sector Shaft Bushes		x				
US 224 A-1	0.2	SET OF 5 BLADES Replacement for Reamer 21 to 24.5 mm		x				
US 224 A-2	0.2	LOCK NUTS (SET OF TWO) For Reamer 21 to 24.5 mm		x				
US 228 A	0.5	STARTER SHAFT BUSHING EXTRACTOR For removing the Starter Shaft Bush in Transmission Case (Old Type, Large I.D. Bushing)	x	x	x			
US 228 B	0.5	STARTER SHAFT BUSHING EXTRACTOR For removing the Starter Shaft Bush in the Transmission Case. (New Type, small I.D. Bush.)	x	x	x			
US 235	4.0	STEERING WHEEL PULLER For pulling the Steering Wheel off the Steering Column		x				
US 236	2.2	PULLER For pulling off the Drop Arm		x				
US 237	3.7	PULLER FOR BALL BEARING For pulling off the Ball Bearing from the Flange of the Differential Housing	x	x	x			



Special TOOLS

TOOL No.	WHGT Lbs	DESCRIPTION	TYPE				NET PRICE US \$	REMARKS
			1	2	3	4		
US 240 A	3.0	DRIFT For installing the Reduction Gear Case and the Bearing Housing on the Rear Axle Tube	x	x				
US 241 A	2.0	BALL BEARING EXTRACTOR. For removing the Outer Ball Bearing of the Driven Gear and Shaft & the Rear Wheel Ball Bearing	x	x	x		For 7 ball Fafnir Brng. use US6306-7	
US 241 A-4	1.0	HOOKS FOR US 241 A (SET OF FOUR) Replacement parts	x	x	x			
US 243	3.0	DRIVER . For installing the Inner Ball Bearing of the driven Gear and Shaft in the Reduction Gear Case		x				
US 244	1.00	DRIVING SLEEVE. For Installing the Spacer of Inner Front Wheel Bearing			x			
US 244 B	2.5	DRIVING SLEEVE For installing the Rear Axle Shaft Outer Ball Bearing & the Spacer of inner Front Wheel Brg.	x	x	x			
US 244 C	1.2	DRIVING SLEEVE For installing the inner Ball Race of the outer Front Wheel Bearing			x			
US 244 D	1.8	DRIVING SLEEVE For driving the Roller Bearing on the Driven Gear and Shaft		x				
US 245 A	2.5	PROTRACTOR For measuring the Camber, the Caster and the Spring Plate Adjustment	x	x	x			
US 245 A-1	0.2	LEVEL FOR US 245 A Replacement part for US 245 A	x	x	x			
US 246	0.2	NO-GO PLUG GAGE For checking the Wear of Starter Shaft Bush. and Gland Nut Bush	x	x	x			
US 248	0.5	MANDREL FOR INSTALLING & REMOVING THE GOVERNOR OIL SEAL For removing the Oil Control Seal of the Gov.			x		Automatic Transmission	
US 249	0.5	CLAMPING PIECE (For AUTOMATIC TRANSMISSION. For checking the Friction Torque			x			

Special TOOLS

TOOL No.	WHGT Lbs	DESCRIPTION	TYPE				NET PRICE US \$	REMARKS
			1	2	3	4		
US 253	0.2	VALVE GAUGE, 7mm	x	x				
US 253 A	0.2	VALVE GAUGE, 8mm	x	x	x			
US 254 A	2.5	CLUTCH ADJUSTMENT GAUGE For all Clutch diameters	x	x	x		Tool US 782 can also be used	
US 254 B	5.0	CLUTCH ADJUSTMENT & REPAIR APPLIANCE For adjusting the Clutch Release Ring In conjunction with Flywheel & US 782	x	x	x			
US 258 A	10.0	STUB AXLE GAUGE For checking the Stub Axles for twist (From Chassis No. I.397023)	x					
US 258 D	1.6	STEERING KNUCKLE PILOT For checking the Steering Knuckle alignment			x			
US 258 F	4.5	STEERING KNUCKLE GAUGE For checking the Steering Knuckles for twist		x			US 258 F/2 included in price	
US 258 F/2	2.0	STEERING KNUCKLE GAUGE SUPPLEMENT For previously supplied US 258 F		x				
US 258 H	5.5	STEERING KNUCKLE GAUGE For checking the Steering Arm on the Steering Knuckle for bend	x					
US 258 M	7.0	STEERING KNUCKLE GAUGE For checking the Steering Arm on the Steering Knuckle for twist	x				Modified per VoA circular T-119-68	
US 258 P	7.0	MEASURING DEVICE FOR STEERING KNUCKLE. For checking the Stub Axle for bends, also for checking the contact surface for caliper	x		x	x	Includes US258K/50	
US 258 K/50	2.0	ADAPTOR FOR MEASURING DEVICE For Tool US 258 K Previously supplied	x		x			
US 259	2.0	TORSION ARM LINK GAUGE For measuring the Torsion Arm Link Offset	x					
US 261	3.0	PROTRACTOR. - For measuring the Alignment on Front Axle Beam & for measuring the Camber	x	x	x			

Special **TOOLS**

TOOL No.	WHGT Lbs	DESCRIPTION	TYPE				NET PRICE US \$	REMARKS
			1	2	3	4		
US 262	5.0	DEVICE FOR CHECKING STEERING ARM FOR TWIST AND WEAR			x			
US 266 H	5.0	TIE ROD END REMOVER For removing all maintenance free type Tie Rod Ends	x		x			
US 267 A	5.0	BALL JOINT REMOVAL TOOL Pressing out the Lower Ball Joint from the Steering Knuckle	x	x				
US 267/4	0.1	CAP NUTS ,M 12 x 1.50 Replacement part for US 267 A Bulletin V-43	x	x				
US 267/5	0.1	CAP NUTS , M 10 x 1.00 Replacement part for US 267 A Bulletin V-43	x	x				
US 267/7	0.1	CAP NUTS , M 18 x 1.50 Replacement part for US 267 A Service Circular #0-90-67	x	x				
US 270 A	1.0	TORSION ARM OFFSET GAGE,PIN DIA 18mm For checking Offset between Upper & Lower Torsion Arms	x					
US 270 B	1.2	TORSION ARM OFFSET GAGE,PIN DIA 20mm For checking Offset between Upper & Lower Torsion Arms		x				
US 270 C	1.3	TORSION ARM OFFSET GAGE,PIN DIA 22mm For measuring Offset between Upper & Lower Torsion Arms		x				
US 273 A	6.0	TORSION ARM BUSHING DRIFT For installing the Torsion Arm Bushes & Needle Bearings in Front Axle Beams	x					
US 273 B	6.0	TORSION ARM BUSHING DRIFT For installing the Torsion Arm Bushes in the Front Axle Beams		x				
US 273 C	4.3	LOWER TORSION ARM BUSHING DRIFT For installing the lower Torsion Arms Bushes and Needle Bearing			x			
US 273 D	4.5	UPPER TORSION ARM BUSHING DRIFT For installing the Upper Torsion Arm Bushes and upper Needle Bearings in the Axle Beam			x			
US 274 A	4.8	TORSION ARM BUSHING REAMER For reaming up the Torsion Arm Bushes Range 36 to 38 mm	x				In wooden box	
US274A-R20	1.0	REAMER HEAD REPLACEMENT Range 36 to 38 mm	x					

Special TOOLS

TOOL No.	WHGT Lbs	DESCRIPTION	TYPE				NET PRICE US \$	REMARKS
			1	2	3	4		
US 274 B	6.0	TORSION ARM BUSHING REAMER For reaming up the Torsion Arm Bushes Range 41 to 44 mm		x			In wooden box	
US274B-R20	1.0	REAMER HEAD REPLACEMENT Range 41 to 44 mm		x				
US 274 C	5.0	CUTTER FOR TORSION ARM BUSHES For cutting the upper and lower Torsion Arm Bushes in the Front Axle Beams			x		In wooden box	
US 276 A	1.5	LOWER TORSION ARM EXTRACTOR For removing the Lower Torsion Arm from the Front Axle Beam			x			
US 277	0.6	OPEN END WRENCH ,41 mm For loosening and tightening the Steering Worm adjusting screw Lock Nut	x		x			
US 278 A	0.6	WRENCH FOR STEERING WORM ADJUST- MENT.For adjusting the Steering Worm in the Roller Type Steering	x		x			
US 279	0.2	STEERING ADJUSTING DEVICE For checking and setting the Free of Play Steering Lock	x		x			
US 280	4.0	ASSEMBLY AND CHECKING DEVICE FOR ROLLER & WORM STEERING	x		x		Including US 280-8	
US 280 - 8	2.0	ADDITIONAL PART FOR TOOL US 280 Previously supplied	x		x			
US 281	2.0	LEVER FOR CHECKING THE PLAY ON THE BALL JOINTS	x					
US 281 A	6.0	BALL JOINT CHECKING DEVICE	x	x	x		Reinforced model	
US 282 B	14.0	TORSION ARM TEST PLATE For checking the Torsion Arms for Parallelism and Twist		x				
US 282 B-3	4.0	CHECKING MANDREL, LONG.Holding dia 20mm.Replacement part for US 282 B		x				
US 282 B-5	4.0	CHECKING MANDREL, SHORT.Holding dia 22mm.Replacement part for US 282 B		x				

**SpecialTOOLS**

TOOL No.	WHGT Lbs	DESCRIPTION	TYPE				NET PRICE US \$	REMARKS
			1	2	3	4		
US 282 D	26.0	TORSION ARM TEST PLATE.LATEST MODEL. For checking the upper & lower Torsion Arms for Parallelism and Twist			x			Price includes US282D-13/18 & US282D/50
US282DI3/18	2.0	SUPPLEMENT TO TOOL US 282 D Additional part for previously purchased US 282 D			x			
US 282D/50	0.6	TORSION ARM GAUGE SUPPLEMENT Additional part for previously purchased US 282 D			x			
US 287 A	9.0	DIFFERENTIAL HOUSING GAUGE For measuring the length of the Differential Housing	x	x	x			
US 288 B	1.5	DIAL BACKLASH GAUGE For measuring the Backlash between Drive Pinion and Ring Gear	x	x				
US 289 D	9.5	TRANSMISSION CASE MANDREL For adjusting the Drive Pinion.For measuring the depth of Transm.Case betw.Differ.Brng.	x	x	x			Price includes the Tool in wooden box
US 292	0.2	CRANKSHAFT END PLAY GAUGE For checking the Crankshaft End Play,for chec- king the End Play of the Oil Pump Gears	x	x	x			
US 293	5.0	DRIVE PINION HOLDING FIXTURE.LATEST MODEL.For loosening and tightening the Round Nut on the Drive Pinion	x	x	x			Price includes US 293/104 US 293/50
US 293/104	0.4	RING for Tool US 293 Previously supplied Workshop Bulletin H of 17 April,1967	x	x	x			
US 293/50	0.4	HOLDING CLAMP FOR NEW LARGE BEAR- ing for Tool US 293 previously supplied	x	x	x			
US 294	11.0	GEARSHIFT TEST APPLIANCE (Old Model)For adjusting Selector Forks	x	x	x			
US 294 A/50	0.4	SUPPLEMENTARY PART For previously supplied Tool US 294 A	x	x	x			
US 294 B	12.0	APPLIANCE FOR ADJUSTMENT OF THE SELECTOR FORKS (NEW MODEL) For adjustment also on TYPE 2/1968	x	x	x			Includes Tools US294A & US 294A-50

Special **TOOLS**

TOOL No.	WHGT Lbs	D E S C R I P T I O N	TYPE				NET PRICE US \$	REMARKS
			1	2	3	4		
US 295	1.5	NEEDLE BEARING DRIFT. For removing and installing the Needle Bearing of the Main Drive on the reserve Gear Shaft	x	x	x			
US 295 A	0.4	ADDITIONAL TOOL FOR US 295 For removing and installing the Needle Bearing of the Main Drive Shaft	x	x	x			
US 296	1.0	TRANSMISSION REMOVAL TOOL For removing the Transmission from Transmission Case	x	x	x			
US 297	10.0	RING GEAR ADJUSTING DEVICE For adjusting the Ring Gear and for various operation on the Transmission	x	x	x		In wooden box	
US 298	0.1	GAUGE RING For adjusting the Ring Gear	x	x	x			
US 299	2.3	ADJUSTING DEVICE FOR CONCAVED WASHER. For determining the thickness of the Shims of the Drive Pinion Concave Washer	x	x	x			

**Special TOOLS**

TOOL No.	WHGT Lbs	DESCRIPTION	TYPE				NET PRICE US \$	REMARKS
			1	2	3	4		
US 307 A	10.0	FIXTURE ,3 ARMS FOR BOTH FLYWHEELS For holding the Engine during assembly and disassembly in conjunction with US 313 Tool	x	x	x		36.00	Price includes Tool US307A-7 Retainer
US 307 A-7	0.2	FLYWHEEL RETAINER FOR BOTH FLYWHEELS Workshop Bulletin M-53	x	x	x			
US 307A/20	2.5	THIRD ARM For previously purchased Tool US 307 Workshop Bulletin M-53	x	x	x			
US 308	52.0	ASSEMBLY STAND, PLAIN	x	x	x			
US 308 A	61.0	ASSEMBLY STAND,WITH ARMS & FORKS	x	x	x			
US 308 B	73.0	ASSEMBLY STAND WITH ARMS & FORKS AND WITH FIXTURE US 313	x	x	x			
US 308 C	86.0	ASSEMBLY STAND WITH ARMS & FORKS & WITH FIXTURES US 313 & US 307 A	x	x	x			
US 309	14.0	HOLDING PLATE For holding the Front Axle during assembly and disassembly	x	x	x			
US 309 A	4.5	FRONT AXLE ADAPTORS -SET OF TWO		x				
US 309 B	2.0	CLAMPS FOR FRONT AXLE- SET OF TWO			x			
US 309 C	6.0	SUPPORT-4 PARTS For holding the Front Axle during assembly in conjunction with US 309,US 313 and US 308	x	x	x			
US 310 A	9.0	FIXTURE For holding the Crankshaft	x	x	x			
US 311 H	17.0	VALVE EXTRACTOR For removing and installing the Valves	x	x	x			
US 313	12.0	FIXTURE For holding the Fixture US 307 A during assembly & disassembly of Engine or Transmiss.	x	x	x			



Special TOOLS

TOOL No.	WHGT Lbs	DESCRIPTION	TYPE				NET PRICE US \$	REMARKS
			1	2	3	4		
US 314	8.0	FIXTURE For tightening & loosening the Nut on the Drive Pinion	x	x	x			
US 328 A	1.2	FUEL PUMP PUSH ROD GAGE	x	x				
US 328 B	1.2	FUEL PUMP DIAPHRAGM GAUGE	x	x				
US 328 A & US 328 B	3.0	SET OF ONE OF EACH	x	x	x		In wooden box	
US 328 C	0.8	FUEL PUMP PUSH ROD GAGE For adjusting the stroke of the vertical drive type Fuel Pump	x	x	x			
US 328 D	0.8	FUEL PUMP DIAPHRAGM GAUGE For adjusting the Diaphragm of the vertical drive type Fuel Pump	x	x	x			
US 328 C & US 328 D	2.0	SET OF ONE OF EACH	x	x	x		In wooden box	
US 330	8.0	CLAMPING AND MEASURING PLATES FOR LIMITED SLIP DIFFERENTIAL. Clamping the partially assembled limited slip differential.		x				
US 341 C	5.0	TOE-IN GAUGE, STANDARD TYPE Range 835-1500 For internal measurements	x	x	x		Matra # CII	
US 350	6.0	RETAINING PLATE WITH MEASURING EQUIPMENT. For holding the final drive for assembly & for adjusting the Ring Gear			x		For Automatic Transmission	
US 351	6.0	HOLDING APPLIANCE FOR REAR AXLE & TRANSMISSION. For use in assembly work			x		For Automatic Transmission	
US 352	12.0	SUPPORT FOR TRANSMISSION Used during assembly work in conjunction with US 309, US 313 and US 308		x				
US 360		REAR AXLE MEASURING ROD	x		x			
US 380	5.5	RING GEAR ADJUSTMENT APPLIANCE FOR AUTOMATIC TRANSMISSION. For adjusting Ring Gear and Drive Pinion.- 4 parts			x			

Special TOOLS

TOOL No.	WHGT Lbs	DESCRIPTION	TYPE				NET PRICE US \$	REMARKS
			1	2	3	4		
US 381	18.0	RING GEAR ADJUSTING APPLIANCE, 15 Parts. For adjusting the Ring Gear and Drive Pinion		x				INCLUDES US 381-50
US 381-50		ADDITIONAL PART for previously supplied US 381		x				
US 382	9.5	TRANSMISSION CASE MANDREL FOR AUTOMATIC TRANSMISSION (10 parts) For adjusting the Ring Gear & Drive Pinion	x					
US 384	6.5	REAR AXLE ADJUSTER			x			

Special **TOOLS**

TOOL No.	WHGT Lbs	DESCRIPTION	TYPE				NET PRICE US \$	REMARKS
			1	2	3	4		
US 400 Z	685.0	15 TON PRESS, TWO STAGE FOOT OPERATED PUMP.(Stenhoj).For pressing operations in conjunction with special tools.	x	x	x			
US 401	5.5	THRUST PLATE For carrying out the many press operations in conjunction with other tools.	x	x	x			
US 402	5.0	THRUST PLATE FOR REMOVING & INSTALLING Roller Bearing & Ball Bearing.For removing the Crankshaft timing Gear,etc.	x	x	x			
US 405	3.0	V-BLOCK PUNCH	x	x	x			
US 406	4.0	V-BLOCKS-SET OF TWO	x	x	x			
US 407	6.0	PUNCH For removing & installing the Axle Shaft Bearing Housing & Reduction Gear Case, Etc.	x	x	x			
US 408 A	2.5	PUNCH For removing and installing the Torsion Arm Link Pin Bushes & Starter Shaft Bushes, Etc.	x	x	x		Tool US 408 Punch discontinued	
US 409	1.3	PUNCH For removing & installing the Ball Bearings on Right & Left Hand Transmission Case Halves	x	x	x			
US 410	1.5	PUNCH For pressing in the Bushes of the Clutch Pedal Shaft, the Gland Nut Bush.	x	x	x			
US 411	1.1	PUNCH For removing & installing the King Pin, the King Pin Bushes & Clutch operating Bushes	x	x	x			
US 412	1.0	THRUST DISC For carrying out a number of operations in conjunction with US 401, Etc.	x	x	x			
US 415 A	2.0	TUBE DIA 60 mm For removing & installing left & right Ball Bearings in Transmission Case.	x	x	x			
US 416 B	1.1	TUBE DIA, 37mm For installing the double Bearing for the Pinion, Etc.	x	x	x		Tool US416A discontinued	
US 417	1.6	TUBE DIA 30 /31.9 mm For installing the Steering worm 16.8 mm dia Lower Thrust Bearing	x					

**Special TOOLS**

TOOL No.	WHGT Lbs	DESCRIPTION	TYPE				NET PRICE US \$	REMARKS
			1	2	3	4		
US 418A	0.8	TUBE,DIA 31.5 mm For removing & installing the Starter Motor Shaft Bush.	x		x			Tool US418 discontinued
US 419	0.7	TUBE ,DIA 32 mm For removing the Gland Nut Bush,The Piston Pin Bush,Etc.	x	x	x			
US 420	1.6	TUBE,DIA 28 mm For removing and installing the reverse sliding Gear Bush	x	x				
US 421	0.7	TUBE,DIA 28 mm For removing & installing the lower King Pin Bush & Shock Absorber Eye Bush,Etc.	x	x	x			
US 422	0.3	TUBE,DIA 28 mm (SPLIT) For removing the King Pin Bush,for installing the 4th Gear & Needle Bearing inner Race	x	x	x			
US 423	0.5	TUBE,DIA 21.5 mm For removing the King Pin Bushes,the Piston Pin Bush	x	x				
US 424	0.5	EXTENSION		x				
US 426	0.2	TUBE,32 mm DIA,45 mm LONG For pressing the Circlip onto the Drive Shaft and the Drive Shaft into the Ball Bearing	x	x	x			
US 427	0.2	GUIDE TUBE For guiding the Crankshaft Timing Gear, Spacer & Distributor Drive Gear,Etc.	x	x	x			
US 428	0.2	GUIDE TUBE,TAPERED For guiding the Distributor Drive Gear retain- ing ring,when pressing it in position	x	x	x			
US 429	0.3	THRUST RING For installing the Distributor Drive Gear Retaining	x	x	x			
US 430	0.5	THRUST PAD For installing the Drive Pinion Roller Bearing, Ball Bearing and Needle Bearing	x	x	x			
US 431	0.5	THRUST PAD 16.5/28 mm DIA For removing the 3rd Gear on Main Drive Shaft of Synchromesh Transmission	x	x				
US 432	4.0	ARBOR,50mm DIA For installing the outer Front Wheel,outer Ball Race and the King Pin Bushes	x	x	x			



Special TOOLS

TOOL No.	WHGT Lbs	DESCRIPTION	TYPE				NET PRICE US \$	REMARKS
			1	2	3	4		
US 433	1.0	THRUST PAD For removing and installing the Differential Bearing in Transmission.	x	x	x			
US 433 A	0.2	SPACER RING For installing the Rear Axle Shaft Bearing Housing on the Axle Tube	x					
US 434	0.3	ARBOR For removing the Torsion Arm Link Pin Bushes	x	x	x			
US 435	0.5	ARBOR For removing and installing the Clutch operating shaft Bushes in Transmission Case	x	x	x			
US 436 A	0.2	GUIDE PIN,TAPERED For pressing out the Clutch Pedal Shaft,for installing Telescopic Shock Absorber Bush.	x	x	x		Tool US436 discontinued	
US 437 A	0.2	GUIDE PIN,TAPERED For installing the Lever Type Shock Absorber	x	x			Tool US437 discontinued	
US 438	0.2	GUIDE PIN,CYLINDRICAL For removing the bushes from Telescopic Shock Absorbers and from Steering Dampers	x	x	x			
US 439	1.2	GUIDE PIN,SHOULDERED For removing and installing the inner Transmission Shift Lever Bushes	x	x	x			
US 440	1.2	SUPPORT RING Pressing out the Steering Ball from the Lower Transmission Arm	x					
US 441	1.5	BASE BLOCK For removing and installing the Rear Wheel Bearing Oil Seal,Etc.	x	x	x			
US 442	1.0	THRUST PAD For installing the Rear Wheel Bearing Oil Seal	x		x			
US 446	1.7	TUBE For removing the inner and outer Front Wheel Bearing for installing Brake Pedal Bushes	x	x	x			

Special **TOOLS**

TOOL No.	WHGT Lbs	DESCRIPTION	TYPE				NET PRICE US \$	REMARKS
			1	2	3	4		
US 447	0.4	THRUST PLATE For removing the Outer Ball Race of the inner Front Wheel Bearing	x	x				
US 447 A	0.4	THRUST PLATE For removing the outer Race of the inner Front Wheel Bearing with 59 mm Dia.	x					
US 447 B	0.5	THRUST PLATE For removing the outer Race of the inner Front Wheel Bearing with 72 mm Dia.		x				
US 447 C	0.2	THRUST PLATE For removing the Outer Race of the Inner Front Wheel Bearing			x			
US 447 D	0.2	THRUST PLATE For removing the Outer Case of the Outer Front Wheel Bearing			x			
US 447 F	0.2	THRUST PLATE For removing the Outer Race of the Outer Front Wheel Bearing with 45mm Dia		x				
US 447 G	0.3	THRUST PLATE For removing the Outer Race of the inside Front Wheel Bearing with 59 mm Dia		x				
US 447 H	0.3	THRUST PLATE For installing the Outer Race of outside Front Wheel Bearing with 45mm Dia		x				
US 447 I	0.4	THRUST PLATE For installing the Outer Race of the Inner Front Wheel Bearing with 59mm Dia		x				
US 448	0.6	THRUST PLATE For removing the Outer Race of the Outer Front Wheel Bearing with 48mm Dia	x					
US 449 A	0.3	TOOTHED THRUST RING For removing the Drive Pinion Roller Bearing Inner Race from the Drive Pinion	x	x				
US 449 B	0.3	TOOTHED THRUST RING For removing the Drive Pinion Roller Bearing inner Race from the Drive Pinion	x	x				
US 449 C	0.3	TOOTHED THRUST RING For removing the Drive Pinion Roller Bearing Inner Race from the Drive Pinion	x	x				
US 449 D	0.3	TOOTHED THRUST RING For removing the Drive Pinion Needle Bearing Inner Race & Ball Bearings		x	x			
US 449 F	0.3	TOOTHED THRUST RING For removing the Drive Pinion Ball Bearing from Drive Pinion	x	x	x			

**SpecialTOOLS**

TOOL No.	WHGT Lbs	DESCRIPTION	TYPE				NET PRICE US \$	REMARKS
			1	2	3	4		
US 450 A	60.0	STAND FOR PRESS TOOLS WITH 7 PLASTIC TRAYS For Tools US 401 and subsequent numbers	x	x	x			
US 450 A-7	5.0	SET OF 7 PLASTIC TRAYS FOR PRESS TOOLS To use on US 450 A Stand	x	x	x			
US 451	0.7	THRUST PLATE For removing the Differential Bearings		x				
US 452	8.0	GEAR CARRIER SUPPORT For removing Transmission out of Gear Carrier	x	x	x			
US 453	4.0	HOLDER FOR BRAKE DRUM			x			
US 454	0.6	PRESSURE PIECE FOR THE DIFFERENTIAL BEARINGS For pressing the Tapered Roller Bearings	x	x	x			
US 455	1.3	SLEEVE FOR DIFFERENTIAL HOUSING BEARING.For pushing on the Differential Housing Tapered Roller Bearings	x	x				
US 456	11.0	SUPPORT FOR GEAR CARRIER For pressing out the Drive Shaft from the Gear Carrier	x	x	x			
US 457	3.6	ANGLED THRUST PLATES FOR DIFFERENTIAL BEARINGS.For pushing off the Bearings of the Differential.	x	x	x		Used with Tool US 456	
US 458	1.3	THRUST PLATE WITH PINS For pushing out the Tapered Roller Bearings from the Final Drive Cover	x	x				
US 459	4.2	THRUST TUBE WITH RING For pressing the Ball Joints into and out of the Torsion Arms		x	x			
US 460	8.0	REMOVAL DEVICE-SET OF 3 PIECES For removing the Upper King Pin from the Steering Knuckle		x	x			
US 461	8.0	KING PIN INSTALLING DEVICE SET OF 7 PIECES		x				
US 463	2.7	REMOVAL & INSTALLATION DEVICE.SET OF 4 PIECES.For pressing or/and installing the Inner Needle Bearing Ring on the Torsion Arm		x				



Special TOOLS

TOOL No.	WHGT Lbs	DESCRIPTION	TYPE				NET PRICE US \$	REMARKS
			1	2	3	4		
US 470	2.5	THRUST PIECES WITH RETAINING RING FOR DRIVE PINION BEARING. For pressing the Tapered Roller Bearings off the Drive Pinion			x		For latest Pinion use US 1010 See Page 32	
US 471	0.6	PEENING TOOL FOR BALL JOINTS THRUST RING. For peening the Ball Joints in the Torsion Arms.		x				
US 472	3.2	THRUST PAD WITH SPACER SLEEVE For pressing the Outer Race of the Tapered Roller Bearing into the Bearing Cover		x				
US 473	3.4	THRUST PIECE. For pressing the Oil Seal out of the Bearing Cover, Etc.	x	x	x			

Special **TOOLS**

TOOL No.	WHGT Lbs	DESCRIPTION	TYPE				NET PRICE US \$	REMARKS
			1	2	3	4		
US 612/2	16.6	SUPPORT FOR ENGINE JACK	x	x	x			
US 612/3	3.5	SUPPORT FOR TRANSMISSION & ENGINE Used in connection with US 612/2	x	x	x			
US 631	8.0	OIL TRAY FOR ASSEMBLY STAND	x	x	x			
US 637-2	1.5	INNER HUB CAP PULLER	x	x	x		US 637-1 discontinued	
US 638	6.0	DRIFT FOR TORSION ARM BUSHINGS	x	x				
US 638/6	0.3	WASHER FOR US 638 Additional Part	x	x				
US 639	4.5	TORSION ARM BUSHING EXTRACTOR			x			
US 642	7.0	REMOVAL TOOL FOR SWING LEVER SHAFT	x	x				
US 644	3.0	EXHAUST TAIL PIPE REMOVAL TOOL	x	x	x			
US 646-1	1.0	DISCHARGE TUBE TOOL 28 Pict. Carburetor	x	x	x			
US 647	0.2	CLIP FOR FUEL TUBE	x	x	x			
US 651	73.0	DISASSEMBLY TROLLEY	x	x	x			
US 652-3	11.0	DISASSEMBLY RACK	x	x	x			
US 652-5	25.0	DISASSEMBLY RACK	x	x	x	x		

**Special TOOLS**

TOOL No.	WHGT Lbs	DESCRIPTION	TYPE				NET PRICE US \$	REMARKS
			1	2	3	4		
US 653-2	2.5	VALVE SPRING COMPRESSING TOOL WITH TUBE	x	x	x			
US 654	1.5	FITTING JIG FOR OIL FILLER			x			
US 655-2	5.0	TORSION ARM TENSIONER	x	x	x		TOOL US 655-1 Discontinued	
US 655-3	6.0	TORSION BAR TENSIONER Latest Model	x	x	x			
US 659-2	1.0	DIAL INDICATOR BRACKET	x	x	x			
US 660	1.0	IGNITION TIMING ADJUSTING GAGE			x			
US 661-2	5.0	OIL COOLER TEST APPLIANCE Modified.	x	x	x			
US 662-2	2.5	OIL PRESSURE SWITCH TESTER	x	x	x			
US 663-1	1.5	FUEL PUMP TESTER	x	x	x			
US 664	2.3	DIFFERENTIAL HOUSING HOLDING FIXTURE	x	x	x			
US 664-1	2.2	DIFFERENTIAL HOUSING HOLDING FIXTURE	x	x	x			
US 665	0.6	OIL PUMP PILOT	x	x	x			
US 667	0.2	CLUTCH CABLE ADJUSTING TOOL	x	x	x			
US 669-1	4.0	TENTION TESTER FOR V-BELT	x	x	x			



Special TOOLS

TOOL No.	WHGT Lbs	DESCRIPTION	TYPE				NET PRICE US \$	REMARKS
			1	2	3	4		
US 674 A	0.4	SPECIAL CROSS KEY (US 674 Discontinued)	x	x	x		Tool US 674 discontinued	
US 676	18.0	CASTER AND BRACKET	x	x	x			
US 681	0.5	EXTRACTOR LEVER FOR MAIN DRIVE SHAFT OIL SEAL	x	x	x			
US 689/1	5.0	Replaced by #4420 VALVE GUIDE WEAR CHECKING DEVICE. See on Page No. 37	x	x	x		Tool US 689/1 discontinued	
US 690	0.8	INSTALLING DEVICE FOR REAR AXLE SHAFT BALL-BEARING		x				
US 691	1.0	ADAPTER FOR TWIN CARBURETOR SYSTEM	x	x	x		Price Includes US 691/1	
US 691/1	0.3	ADDITIONAL PART FOR US 691	x	x	x			
US 691 A	0.5	SYNCHRONIZER Used with Tool US 691	x	x	x			
US 692	0.5	FITTING SLEEVE			x			
US 693	0.6	DEVICE FOR PRESSING OUT THE DRIVEN GEAR & SHAFT OF THE REAR AXLE		x				
US 694	0.5	PULLER FOR SEALING CAP		x				
US 697	30.0	TEST APPLIANCE FOR FRAME HEAD			x			
US 699	0.1	FITTING SLEEVE	x	x	x			
US 699-64	0.3	See with other Cutters on Page No. 35						

Special TOOLS

TOOL No.	WHGT Lbs	DESCRIPTION	TYPE				NET PRICE US \$	REMARKS
			1	2	3	4		
US 705	0.5	DISASSEMBLY TOOL For Window Handle	x	x	x			
US 709		TORSION BAR TENSIONING TOOL						
US 710		ASSEMBLY WRENCH For Compartment Lid Lock						
US 736-1	0.5	HEADLINING TOOL	x	x	x			
US 753	0.3	APPLIANCE FOR CHECKING BRAKE LINING WEAR		x	x			
US 756	5.0	LOWER FRONT AXLE BUSHING DRIFT			x			
US 757	4.0	UPPER FRONT AXLE BUSHING DRIFT			x			
US 758/1	0.5	ADAPTER FOR STEERING WORM Used when making adjustments to the Steering Gear	x	x	x			
US 759	1.0	APPLIANCE FOR CHECKING BRAKE DRUM OVALITY	x	x	x			
US 760		KING PIN BUSH SLOTTING TOOL (Upper King Pin Bushes)	x					
US 761	0.2	BACKLASH CHECKING HOLDER	x	x				
US 767	5.0	DRIFT FOR LOWER TORSION ARM BEARING	x					
US 768	5.0	DRIFT FOR UPPER TORSION ARM BEARING	x					
US 769	1.0	DIAL INDICATOR BRACKET FOR WHEEL BEARING ADJUSTMENT	x	x	x			

**Special TOOLS**

TOOL No.	WHGT Lbs	DESCRIPTION	TYPE				NET PRICE US \$	REMARKS
			1	2	3	4		
US 771	17.0	SLIDE HAMMER,Multi-purpose		x				
US 771-22		ADDITIONAL PART FOR US 771 Multi-purpose Tool	x		x			
US 772	7.0	DRIFT FOR BEARING						
US 774	0.3	TOOL FOR CHECKING DISC BRAKE PAD WEAR	x		x		DZ-1500-1 Also in Brake Tool Section	
US 775		PULLER FOR WHEEL CAPS	x	x	x			
US 776	2.5	RETAINING BRACKET For Lower Beam Lever (2 Pcs Set)			x			
US 778	0.4	INSTALLING SLEEVE(Inserting Tool) For plastic Retaining Rings	x					
US 780-1	1.0	INSTALLING SLEEVE FOR RETAINING RING Upper,42.6 mm Dia.	x					
US 780-2	1.0	INSTALLING SLEEVE FOR LOWER RETAIN- ING RING. 38.5 mm Dia.	x					
US 782	4.0	ADJUSTING BOW,DIAL INDICATOR HOLDER & T-HANDLE FOR CLUTCH	x	x	x		3 Pcs Set Incl.US659-1	
US 784	3.0	TRANSMISSION SUPPORT		x				
US 785	7.5	TRANSMISSION SUPPORT			x			
US 785-1		TRANSMISSION SUPPORT Used when removing Engine			x			
US 786	0.6	RETAINING BRACKET FOR PINION			x			



Special TOOLS

TOOL No.	WHGT Lbs	DESCRIPTION	TYPE				NET PRICE US \$	REMARKS
			1	2	3	4		
US 787	1.0	TRAY FOR PARTS OF AUTOMATIC Transmission			x			
US 789	0.3	PLASTIC KNOB REMOVAL TOOL	x		x			
US 790	1.0	TOOTHED T-LEVER FOR TURNING ENGINE			x			
US 791	4.0	LONG T-WRENCH WITH FLEXIBLE JOINT SOCKET,21mm.For turning Engine.	x				Automatic	
US 792	7.0	OIL SEAL FITTING TOOL	x					
US 797/1		ASSEMBLY APPLIANCE FOR FUEL PUMP For 25 & 30 bhp Engines	x	x				
US 797/2		ASSEMBLY APPLIANCE FOR FUEL PUMP For 34 to 54 bhp Engines		x	x			
US 797/3		ASSEMBLY APPLIANCE FOR FUEL PUMP For 68 bhp Engine.				x		
US 799	0.4	DOOR SPRING PLIER Range 210 mm.For removing and installing of door and window handle.	x	x	x		Hazet	



Special TOOLS

HEX KEYS special sockets AND ATTACHMENTS

TOOL No.	WHGT Lbs	DESCRIPTION	TYPE				NET PRICE US \$	REMARKS
			1	2	3	4		
911- 2.5 mm	0.05	2.5 mm DIN 911 HEX KEY			x			
911- 6 mm	0.2	6 mm DIN 911 HEX KEY					Old No. US 1002	
911- 10	1.0	SET OF HEX KEYS (10 Pcs Set) 1.5 mm to 12 mm	x	x	x			
JT - 5	0.2	5 mm HEX KEY SOCKET 3/8" DRIVE			x			
JT - 6	0.2	6 mm HEX KEY SOCKET 3/8" DRIVE	x	x			Old No. #2584	
R 8	0.1	8 mm, 12 POINTS, 1/4" DRIVE SOCKET Because of limited working space J 8 3/8" drive socket was discontinued.	x					
US 156	0.1	HEX KEY, 8mm, 1/2" DRIVE. For loosening and tightening Connecting Rod Bolts, Socket Head Screws of Front Torsion Bar	x	x			Illustration on page 59 Hazet	
US 157	0.2	HEX KEY, 10mm, 1/2" Drive To use on Cylinder Head Nuts	x	x			Illustration on page 59 Hazet	
US 162	0.3	SOCKET, 32mm, 1/2" Drive, 6 Point	x	x	x		Illustration on page 60 Hazet	
US 163 A	0.5	SOCKET, 36mm, 3/4" Drive, 6 Point For Loosening Rear Axle Shaft Nut	x	x			Illustration on page 60 Hazet	
US 163 B	1.4	46 mm 3/4" Drive, 6 Point SOCKET		x	x			
US 163 C	1.0	41 mm 3/4" Drive, 6 Point SOCKET		x				
US 163 D	0.1	8 POINT 1/4" DRIVE SPECIAL SOCKET			x			
US 163 E	0.2	3/8" Drive No.2 PHILLIPS SCREW DRIVER SOCKET			x			
US 163 F	0.1	REDUCTION FROM 3/8" to 1/4 "			x			



Special TOOLS

special sockets

TOOL No.	WHGT Lbs	DESCRIPTION	TYPE				NET PRICE US \$	REMARKS
			1	2	3	4		
US 173	0.3	SPECIAL SOCKET, 1/2" Drive for SAXOMAT AUTOMATIC CLUTCH. Used on Gland Nut.	x				Illustration on Page 60	
US 174	0.1	SPECIAL SOCKET, 1/2" Drive for SAXOMAT AUTOMATIC CLUTCH. Used on Socket Head.	x				Illustration on Page 60	
2286/64	0.3	SPECIAL SOCKET, 11mm For Brake Hose						
2287/64	0.3	SPECIAL SOCKET, 14mm For Brake Hose						
INX 19/M6	0.3	SPECIAL MULTI-POINT SOCKET	x					
INX 19/M8	0.4	SPECIAL MULTI-POINT SOCKET	x					
US 1001	0.2	17mm 1/2" DRIVE TORQUE WRENCH EXTENSION					See also in Torque Wrench Section	
US 1002	0.2	6 mm Din 911 HEX KEY					NEW No. 911-6mm	
US 1003	0.2	19 mm 1/2" DRIVE TORQUE WRENCH EXTENSION					See also in Torque Wrench Section	
US 1004	0.5	SPECIAL WRENCH, 10mm Long Handle For Cylinder intake Port Pipes			x			
US 1011		COUNTERSINKING TOOL For Crankcase Stud Holes					VWoA Serv. Circular # T-13-69	
US 1024	0.3	SPECIAL WRENCH WITH PERMANENT MAGNET, 17 mm, 12 Points.						

Special **TOOLS**

torque wrenches and EXTENSIONS

US SP50

TORQUE WRENCH, 3/8" DRIVE. 0-50 Inch Pound Scale Type. Same as SP 30 but Plastic Knob is modified to 90° angle. Replaces SP 30 and US 547 VZ

NET PRICE US\$ _____



US 547 A

ADAPTER 1/4-3/8-1/2" DRIVE WITH 32 mm 1/2" Drive 12 Point Socket.

NET PRICE US\$ _____

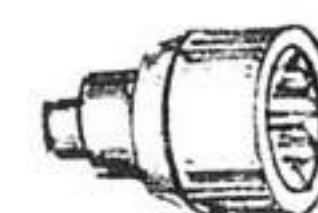

US 118/2

SPECIAL TORQUE WRENCH, 0-2 mkg, 3/8" Drive

NET PRICE US\$ _____

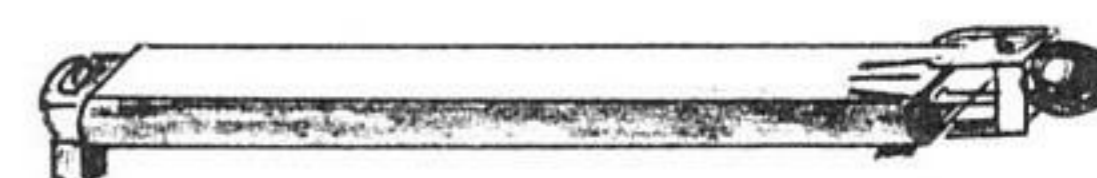

US 118/6H

TORQUE WRENCH, T-Handle, 1/2" Drive, Up to 6 mkg.

NET PRICE US\$ _____

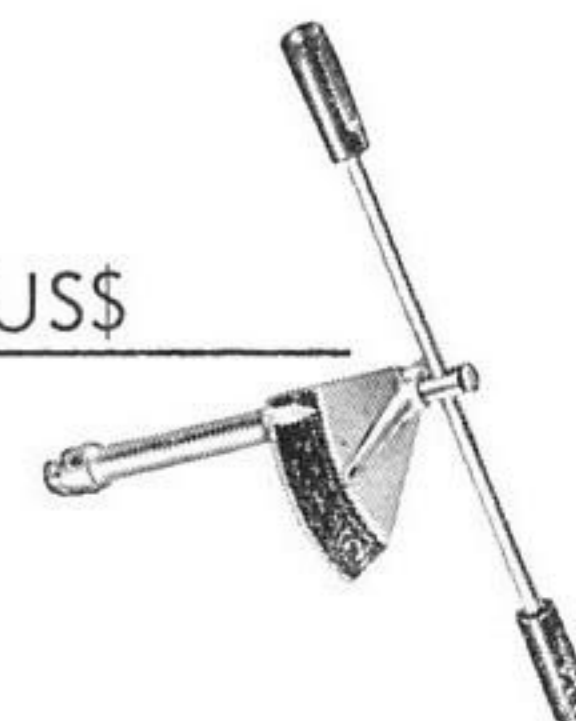

US 118/20

TORQUE WRENCH, 1/2" Drive, Dual Scale, 0-20 mkg. 150 Lbs. In Meter Kilogram & Foot Pound.

NET PRICE US\$ _____

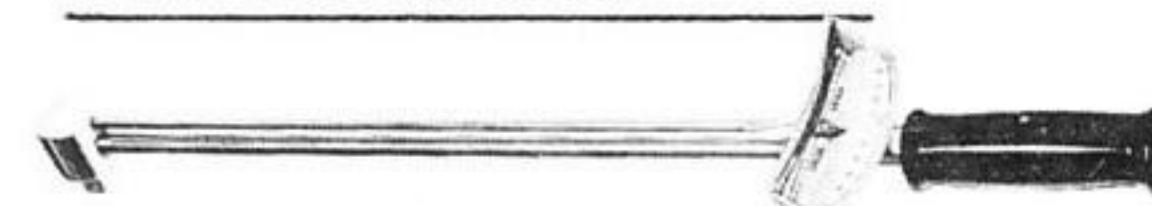

US 118/40

TORQUE WRENCH, 3/4" Drive, Dual Scale, 0-40 mkg. 300 Lbs. In Meter Kilogram and Foot Pound.

NET PRICE US\$ _____



US 1001

17 mm, 1/2" Drive TORQUE WRENCH EXTENSION
Listed also with Special Sockets

NET PRICE US\$ _____

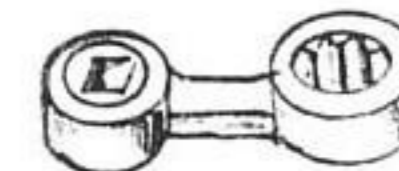

US 1003

19 mm 1/2" Drive TORQUE WRENCH EXTENSION
Listed also with Special Sockets.

NET PRICE US\$ _____

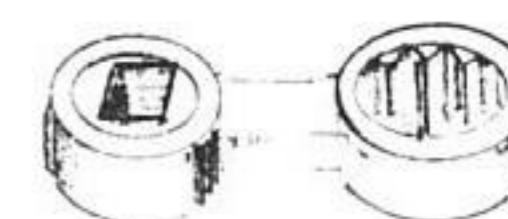

Special **TOOLS**

extractors and pullers

TOOL No.	WHGT Lbs	DESCRIPTION	TYPE				NET PRICE US \$	REMARKS
			1	2	3	4		
21/7		INTERNAL EXTRACTOR			x			
22/2		SPINDLE . Used with Tool 21/7			x			
6305		BALL BEARING EXTRACTOR for outer Ball Bearing of Reduction Gearcase of VW-Transporter		x			Rillex	
6306 - 7		BALL BEARING EXTRACTOR for Rear Wheel Flywheel Shaft & Inner Rear Axle Shaft Ball Bearing of Reduction Gearcase.(VW Transp.)		x			Rillex 7 Ball FAFNIR Bearing	
US 1010		PULLER FOR PINION BEARING			x		Same use as Tool US 470	
US 202 BZ		EXTRACTOR-COMplete UNIT FOR REMOVING BRAKE DRUMS & BRAKE DISCS	x	x	x		US 202 C Tool discontinued	
US 235	4.0	STEERING WHEEL PULLER.For pulling the Steering Wheel off the Steering Column.		x				
US 236	2.2	PULLER For pulling off the Drop Arm		x				
US 237	3.7	PULLER FOR BALL BEARING	x	x	x			
US 241 A	2.0	BALL BEARING EXTRACTOR .For removing the Outer Ball Bearing of the Driven Gear and Shaft.	x	x	x			
US 241 A-4	1.0	HOOKS for US 241 A(Set of 4) Replacement parts.	x	x	x			
US 266 H	5.0	TIE ROD END REMOVER .For removing all Maintenance free type Tie Rod ends.	x		x			
US 267 A	5.0	BALL JOINT REMOVAL TOOL Pressing out the Lower Ball Joint	x	x				
US 276 A	1.5	LOWER TORSION ARM EXTRACTOR.For removing Torsion Arm from Front Axle Beam.			x			
US 639	4.5	TORSION ARM BUSHING EXTRACTOR			x			



Special TOOLS

Disc Brake TOOLS

TOOL No.	WHGT Lbs	DESCRIPTION	TYPE				NET PRICE US \$	REMARKS
			1	2	3	4		
3.9314-1800.2	1.5	PISTON RETAINING PLIER	x		x			
3.9314-1500.2	0.7	PISTON ROTATING PLIER New Model	x		x			
3.9314-2400.1	0.1	PISTON SETTING GAUGE (Modified old No.3.9314-0900.1)	x		x			
3.9314-1400.2	0.5	EXTRACTOR HOOKS	x		x			
3.9314-2203.2	0.8	MEASURING APPLIANCE DIAL GAUGE BRACKET.New Model.	x		x		Replacing #3.0314-1300.2	
3.9314-2300.2	2.0	PISTON INSTALLING CLAMP FOR DISC BRAKES GUIDE	x		x			
TZ 1500-6	5.5	COMPLETE TOOL SET,Consisting of the above listed 6 Tools VW Bulletin # B-59	x		x			
3.9314-2202.1	0.2	BLOCKS,2 Pcs	x		x			
3.9314-2201.2	0.3	SWIVELING ARM	x		x			
3.9314-3100.1	0.2	FITTING SLEEVE I.D. 19.05 mm	x		x		Also No.4425	
3.9314-3200.1	0.3	FITTING SLEEVE I.D.22.2 mm		x			Also No.4426	
DZ-1500-1	0.3	GAUGE ,For checking Pad Thickness on Disc Brakes	x		x		Also No.US 774	

Special **TOOLS**

VALVE SEAT CUTTERS and accessories

1600-AV VALVE SEAT CUTTER KIT

1600 - AV NET PRICE
US \$

CONSISTING OF:

- # 204 15° & 46° Seat Cutter
 - # 209 15° & 46° Seat Cutter
 - # 211 60° & 75° Seat Cutter
 - # 150-7 7 mm Expandable Pilot
 - # 150-8 8 mm Expandable Pilot
 - # 503 1/2" T-Wrench (2 Pcs)
 - # 245 Pilot Puller Pin
 - # 240 1 Pc 5/64 (2mm) Hex Key
1 Pc 3/32 (2.4mm) Hex Key
- IN PLASTIC BOX.

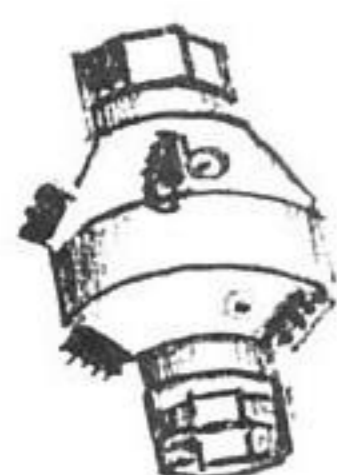

204
15° & 46° Seat Cutter
NET PRICE US\$



209
15° & 46° Seat Cutter
NET PRICE US\$

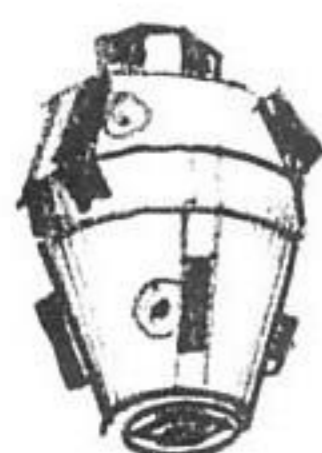

211
60° & 75° Seat Cutter
NET PRICE US\$

ALL ABOVE SEAT CUTTERS
WITH CARBIDE BLADES

CARBIDE BLADES
for Seat Cutters :



- # 250 3/8" long for # 204 & # 209
Seat Cutter Heads
- # 252 1/2" long for #211 Seat Cutter Head

NET PRICE
US \$
Each Blade

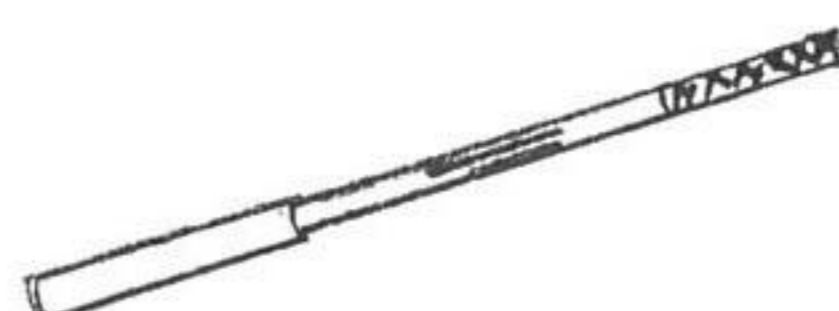

150-7
7mm Expandable Pilot
NET PRICE US\$



150-8
8 mm Expandable Pilot
NET PRICE US\$

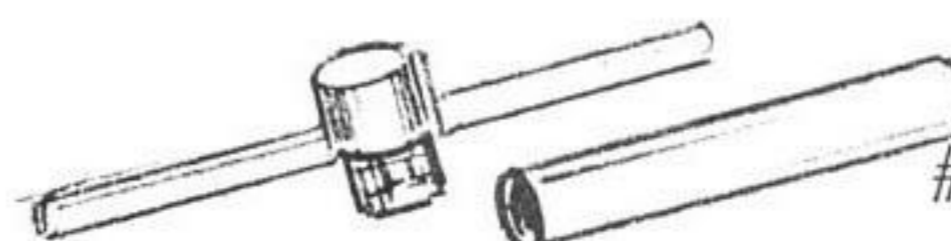

503
1/2" T-Wrench(2 Pcs)
NET PRICE US\$



#245
Pilot Puller Pin
NET PRICE US\$



240 5/64 Hex Key
241 3/32 Hex Key
NET PRICE US \$ /Ea.

NEW A Y VALVE SEAT CUTTERS

Special**TOOLS**

valve service tools

TOOL No.	WHGT Lbs	DESCRIPTION	TYPE				NET PRICE US \$	REMARKS
			1	2	3	4		
US 253	0.2	VALVE GAGE, 7 mm Dia.	x	x				
US 253 A	0.2	VALVE GAGE, 8 mm Dia.	x	x	x			
US 3II-I	0.2	CYLINDRICAL WIRE BRUSH, 20 mm Dia.	x	x	x			
US 3II-2	0.3	VALVE GUIDE REAMER , 7 mm Dia.	x	x			See also # 4411	
US 3II-3	0.3	VALVE GUIDE REAMER, 8 mm Dia.	x	x	x		See also # 4412	
US 3II C	0.4	CHUCK, 7 mm Dia.	x	x				
US 3II F	0.5	CHUCK, 8 mm Dia.	x	x	x			
US 3II-I2	0.3	VALVE RESEATER WITH SUCKER	x	x	x			
US 3II K-16	0.4	VALVE GUIDE PILOT , 7 mm Dia.	x	x			For Matra Service Tool	
US 3II K-17	0.4	VALVE GUIDE PILOT, 8 mm Dia.	x	x	x		For Matra Service Tool	
US 3II K-20	0.4	VALVE GUIDE BRUSH, 7 mm Dia.	x	x				
US 3II K-21	0.5	VALVE GUIDE BRUSH , 8 mm Dia.	x	x	x			
US 653-2	2.5	VALVE SPRING COMPRESSING TOOL	x	x	x			
US 699-64	0.3	VALVE GUIDE CUTTER	x	x	x			

Special**TOOLS**

valve service tools

TOOL No.	WHGT Lbs	DESCRIPTION	TYPE				NET PRICE US \$	REMARKS
			1	2	3	4		
4400	22.5	VALVE GUIDE REPLACEMENT KIT, COMPLETE.	x	x	x			
		P A R T S :						
4401	15.0	ANGLE PLATE WITH 2 PINS	x	x	x			
4404	6.0	CLAMPING PLATE	x	x	x			
4405	0.2	7/9 mm SHOULDERED DRILL	x	x				
4406	0.2	8/11 mm SHOULDERED DRILL	x	x	x			
4407	0.2	7 mm VALVE GUIDE DRIFT	x	x				
4408	0.2	8 mm VALVE GUIDE DRIFT	x	x	x			
4409	0.2	7 mm VALVE GUIDE ARBOR	x	x				
4410	0.2	8 mm VALVE GUIDE ARBOR	x	x	x			
4411	0.1	7 mm REAMER	x	x			See also US 311-2	
4412	0.1	8 mm REAMER	x	x	x		See also US 311-3	
4414	0.6	DRILL GUIDE KIT, Recommended for above set. This Kit helps to avoid breakage of the Shouldered Drills.	x	x	x			

Special **TOOLS**

valve service tools

TOOL No.	WHGT Lbs	DESCRIPTION	TYPE				NET PRICE US \$	REMARKS
			1	2	3	4		
4420		VALVE GUIDE CLEARANCE CHECKING DEVICE. VWoA Serv.Circular 0-46-66	x		x			US 689/1 is replaced by this No.
		P A R T S :						
4420-1		BASE PLATE FOR MAGNET WITH ECCENTER						
4420-2		ECCENTRIC PIN						
4420-3		UNIVERSAL MAGNET WITH 2 ADJUSTABLE BARS AND UNIVERSAL JOINT						
4420-4		DIAL INDICATOR BRACKET						
4420-5		FLAT EXTENSION WITH 2.6 mm SCREW						
4420-6		TWO 8mm WING NUTS To fasten Cylinder on Clamping Plate						
4421		TEMPLATE For Brake Pad adjusting	x					
4423		TEMPLATE For Brake Pad adjusting			x			
4424		SUPPORT BAR Used with Disc Brake Tool						
4425	0.2	FITTING SLEEVE (Brake Cylinder) I.D.19.05 mm	x		x			Also #3.9314- 3100.1
4426	0.3	FITTING SLEEVE (Brake Cylinder) I.D.22.2 mm		x				Also #3.9314- 3200.1
4427		INSTALLING SLEEVE.For installing the Ball Joint Rubber Booths.		x				

Special**TOOLS**

TOOL No.	WHGT Lbs	D E S C R I P T I O N	TYPE				NET PRICE US \$	REMARKS
			1	2	3	4		
US 4430		FRAME JIG. To check Missalignment and for replacement of Frame Head	x				Includes US 4430-5 Protractor	
US 4430-5		PROTRACTOR for measuring. Used in connection with US 4430	x					
		CHECKING TOOLS FOR AUTOMATIC TRANSMISSION						
US 4431		DISTANCE BRIDGE Center points distance 40 mm	x					
US 4432		FEELER GAGE 12" long. 4mm & 6.5mm.	x					
US 4433		FEELER GAGE 5" long. 9.2mm.	x					
US 4434		DISTANCE BRIDGE for SERVO-CLUTCH Rod	x					

TOOL #	D E S C R I P T I O N	NET PRICE	REMARKS
2502	SPECIAL SPARKPLUG WRENCH Hazet Chrome Vanadium		
2560	DOUBLE HEX BOX WRENCH, 27 x 36 mm Hazet Chrome Vanadium		
2561	DOUBLE HEX BOX WRENCH , 21 x 36 mm Hazet Chrome Vanadium		
2566	SPECIAL TOOL For the Switch of the Windshield Wiper		
2567	SPECIAL WRENCH FOR OIL SERVICE Hazet Chrome Vanadium		
2568	ADJUSTING VALVE WRENCH, 13 mm Hazet Chrome Vanadium		
2569	SPECIAL WRENCH, 17 mm For adjusting Roller, Worm & Steering Hazet Chrome Vanadium		
2573	SPECIAL WRENCH, 10 mm, length 285 mm. For removing & tightening of Nuts on Manifold of Cylinder Head. Hazet Chrome Vanadium		
2577	DOUBLE BOX WRENCH, 17 x 22 mm. Opening 22 mm is used for installing Back-up light. Opening 17mm for screw on Gear Box		
2578	SPECIAL WRENCH. For tightening nuts on Oil Pump Cover's right & left side. Hazet Chrome Vanadium		
2579	SPECIAL BOX WRENCH, 13 x 13 mm Hazet Chrome Vanadium		
2582	ADJUSTING LEVER FOR BRAKE SHOES Hazet Chrome Vanadium		
2587	SPECIAL WRENCH, 15° & 60°. For removing and tightening Free-run Nozzle on SOLEX-Carburetor. Hazet Chrome Vanadium		
4513-13	SPECIAL SOCKET, 13 mm with Folding Screw Driver . To use on SOLEX-Carburetor. Hazet Chrome Vanadium		
4513-14	SPECIAL SOCKET, 14 mm with Folding Screw Driver. To use on SOLEX-Carburetor. Hazet Chrome Vanadium		
615-11x13	DOUBLE-HEX STARTER & BLOCK WRENCH Hazet Chrome Vanadium		
650-16	TIRE IRON , 16" long Hazet Chrome Vanadium		
2165-1	PRY BAR, For lifting Cylinder-Heads, taking off Gears, Bushings Hazet Chrome Vanadium		
2165-2	PRY BAR, For lifting Cylinder Heads, taking off Gears, Bearings. Hazet Chrome Vanadium		

Special **TOOLS** PLIERS

TOOL No.	WHGT Lbs	DESCRIPTION	TYPE				NET PRICE US \$	REMARKS
			1	2	3	4		
US 122 B	0.3	CIRCLIP PLIER, For removing & installing Piston Pin Circlips.						Hazet
Z-P 126	0.5	NEEDLE NOSE PLIER Length 145 mm						
US 161 A	0.7	CIRCLIP PLIER For removing & installing circlip on Drive Pinion, on Hand Brake Lever Pin, etc.						Hazet
429	0.2	HOSE CLAMP PLIER Removes & installs all sizes clamps						
O300	0.3	CIRCLIP PLIER, Straight tips for INTERNAL Lock Rings, Length 180mm. Tips Dia 1.8 mm (0.07 inches)						
O400	0.3	CIRCLIP PLIER, Straight tips for EXTERNAL Lock Rings, Length 180mm. Tips Dia 1.8 mm (0.07 inches)						
O404	0.3	CIRCLIP PLIER, bent tips 45° For EXTERNAL Lock Ring, Length 180mm. Tips Dia. 1.8 mm (0.07 inches)						
O409	0.3	CIRCLIP PLIER, bent tips 90° For EXTERNAL Lock Ring, Length 180mm. Tips Dia. 1.8 mm (0.07 inches)						
O500	0.5	CIRCLIP PLIER, Straight tips for INTERNAL Lock Rings, Length 220 mm. Tips Dia. 2.5 mm (0.09 inches)						
O504	0.5	CIRCLIP PLIER, Bent tips 45° For INTERNAL Lock Ring, Length 220 mm Tips Dia. 2.5 mm (0.09 inches)						
O600	0.5	CIRCLIP PLIER, Straight Tips for EXTERNAL Lock Rings, Length 220 mm Tips Dia. 2.5 mm (0.09 inches)						
O604	0.5	CIRCLIP PLIER, Bent tips 45° For EXTERNAL Lock Ring, Length 220 mm. Tips Dia. 2.5 mm (0.09 inches)						
Z-P 316	0.7	DIAGONAL CUTTING PLIER Length 160 mm						
Z-P 760	1.0	WATERPUMP PLIER Length 240 mm						
US 799	0.3	DOOR SPRING PLIER, Range 210mm, For removing & installing of Door & Window Handle.						
1515	0.5	HORSE SHOE LOCK RING PLIER						

Special **TOOLS**

FILES
PUNCHES
CHISELS
miscellaneous tools

TOOL No.	WHGT Lbs	DESCRIPTION	TYPE				NET PRICE US \$	REMARKS
			1	2	3	4		
ZF-8729-6		IGNITION POINT FILES Set of 6 Pcs., 6" long.						
F - 8701-2		FILE, Flat, 10" long						
F - 8719 - 2		FILE, Triangle, 10" long						
F - 8722-2		FILE, Round, 10" long						
C 352-112		FLAT CHISEL, 11 mm						
C 352-116		FLAT CHISEL ,15 mm						
DP 355-99		DRIFT PUNCH, 2mm Dia.						
DP 355-103		DRIFT PUNCH, 4 mm Dia.						
CP 350-101		CENTER PUNCH, 10 mm Dia.						
O 102		PLASTIC OILER, 0.025 liter						
O 100		PLASTIC OILER, 0.25 liter						
O 103		METAL OILER WITH PUMP LEVER 0.25 liter						
Z-8551-66		SCREW EXTRACTOR SET for Dia. 1.4 to 16 mm						
TF-4595-1		COPPER TUBE FLARING TOOL For Tubes Dia. 4, 4.75 , 6 , 8 , 10 , 12 , 14 mm OD						
R.A.P.A.		TEST LAMP. 6-12 volts						

Special **TOOLS**

hammers

CATALOG No.	DESCRIPTION	UNIT PRICE US \$	REMARKS
H 8605-1	GERMAN TYPE ENGINEER'S HAMMER ,Weight 100 grams		
H 8605-2	GERMAN TYPE ENGINEER'S HAMMER,Weight 200 grams		
H 8605-3	GERMAN TYPE ENGINEER'S HAMMER,Weight 300 grams		
H 8605-5	GERMAN TYPE ENGINEER'S HAMMER,Weight 500 grams		
H 268-22	SOFT FACE HAMMER, DIA 22 mm		
H 268-30	SOFT FACE HAMMER, DIA 30 mm		
H 268-40	SOFT FACE HAMMER, DIA 40 mm		
RM 258	RUBBER MALLET,DIA 57 mm		

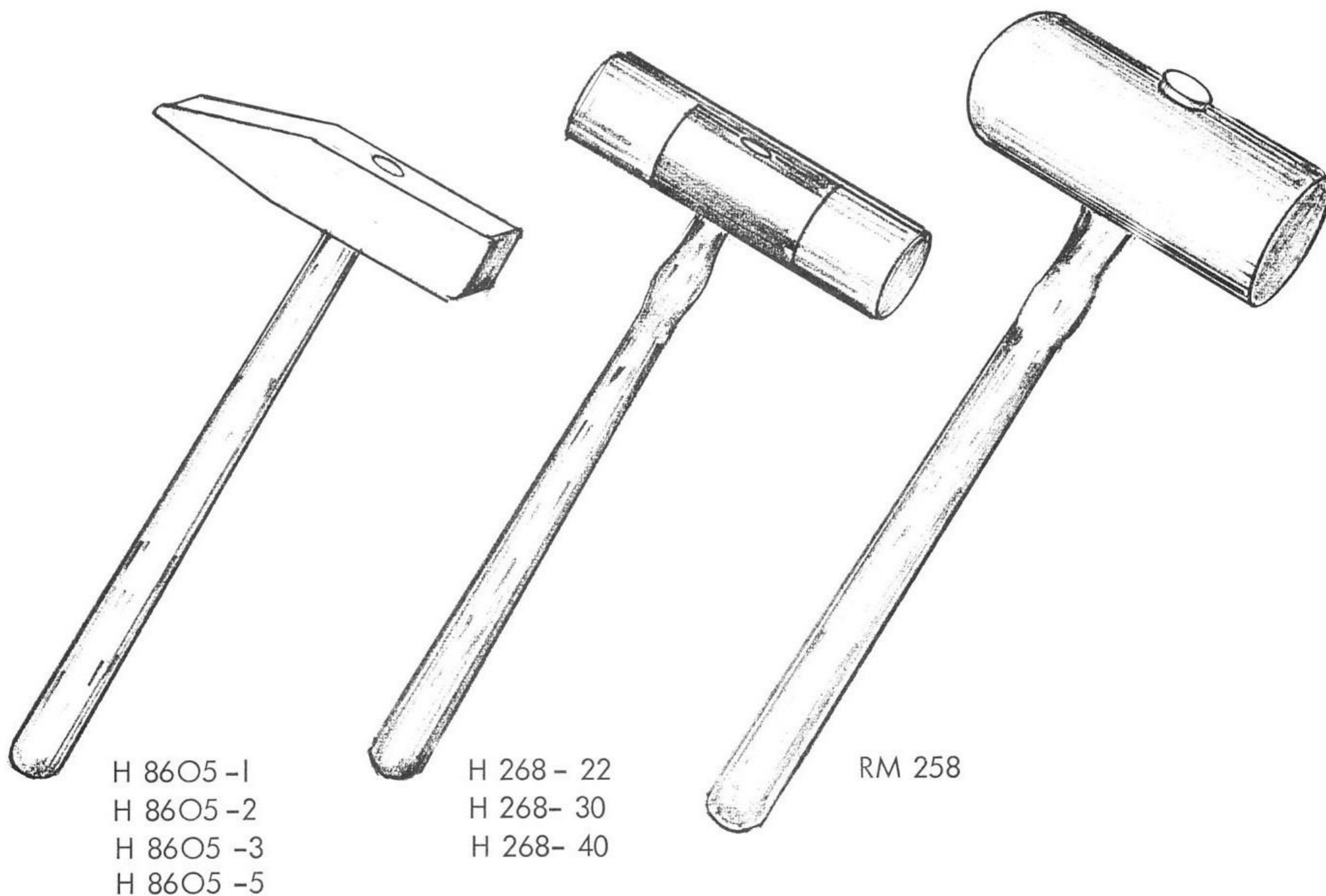

H 8605 -1
H 8605 -2
H 8605 -3
H 8605 -5

H 268 - 22
H 268- 30
H 268- 40

RM 258

Special **TOOLS**

screwdrivers

CATALOG No.		BLADE LENGTH		TIP WIDTH	WEIGHT Lbs.	NET PRICE	REMARKS
<u>ELECTRICIANS ROUND BLADE</u>							
DE - 43		3"		3/16	0.1		
DE - 46		6"		3/16	0.14		
DE - 50		10"		3/16	0.14		
DE - 52		2-1/4"		1/8	0.05		
<u>MECHANICS SQUARE BLADE</u> With Cushion Grip							
DSG - 4		4"		9/32	0.2		
DSG - 6		6"		5/16	0.4		
DSG - 8		8"		3/8	0.6		
DSG-62		1-1/4"		1/4	0.15		
<u>PHILLIPS</u> With Cushion Grip							
DPG - 1		3"		# 1	0.06		
DPG - 2		4"		# 2	0.2		
DPG - 3		6"		# 3	0.3		

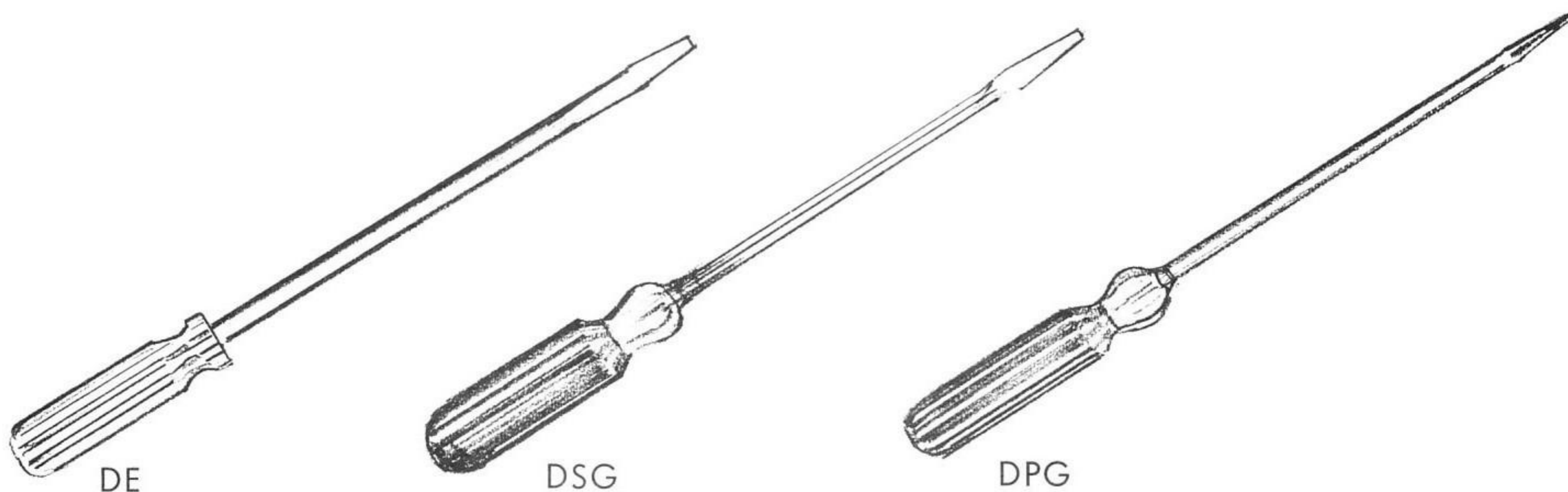

Special **TOOLS**

GAGES

CATALOG No.	DESCRIPTION	NET PRICE US \$	REMARKS
804	PRECISION FEELER GAGE Blade length 95 mm,width 10 mm,With 18 blades in mm: 0.04 0.05 0.06 0.07 0.08 0.09 0.10 0.15 0.20 0.25 0.30 0.40 0.50 0.60 0.70 0.80 0.90 1.00		
A 23	PRECISION FEELER GAGE Blade length 300 mm,width 13 mm,With 13 blades in mm: 0.05 0.10 0.15 0.20 0.25 0.30 0.40 0.50 0.60 0.70 0.80 0.90 1.00		
82	SCREW PITCH GAGE METRIC,Thread 60°,20 blades,Pitch 0.25 to 5 mm.Measuring range M2 to M60.Precision model for external & internal threads.		
2520-10	VALVE SETTING GAGE,With 10 spare blades Thickness of blade 0.1 mm		Hazet
2520-10 BL	10 SPARE BLADES FOR ABOVE Thickness of Blade 0.1 mm.Packed 10 pcs.		Hazet
2520-20	VALVE SETTING GAGE, With 10 spare blades Thickness of blade 0.2 mm		Hazet
2520-20 BL	10 SPARE BLADES FOR ABOVE Thickness of blade 0.2 mm.Packed 10 pcs.		Hazet
2520-30	VALVE SETTING GAGE,With 10 spare blades Thickness of blade 0.3 mm		Hazet
2520-30 BL	10 SPARE BLADES FOR ABOVE Thickness of blade 0.3 mm.Packed 10 pcs.		Hazet

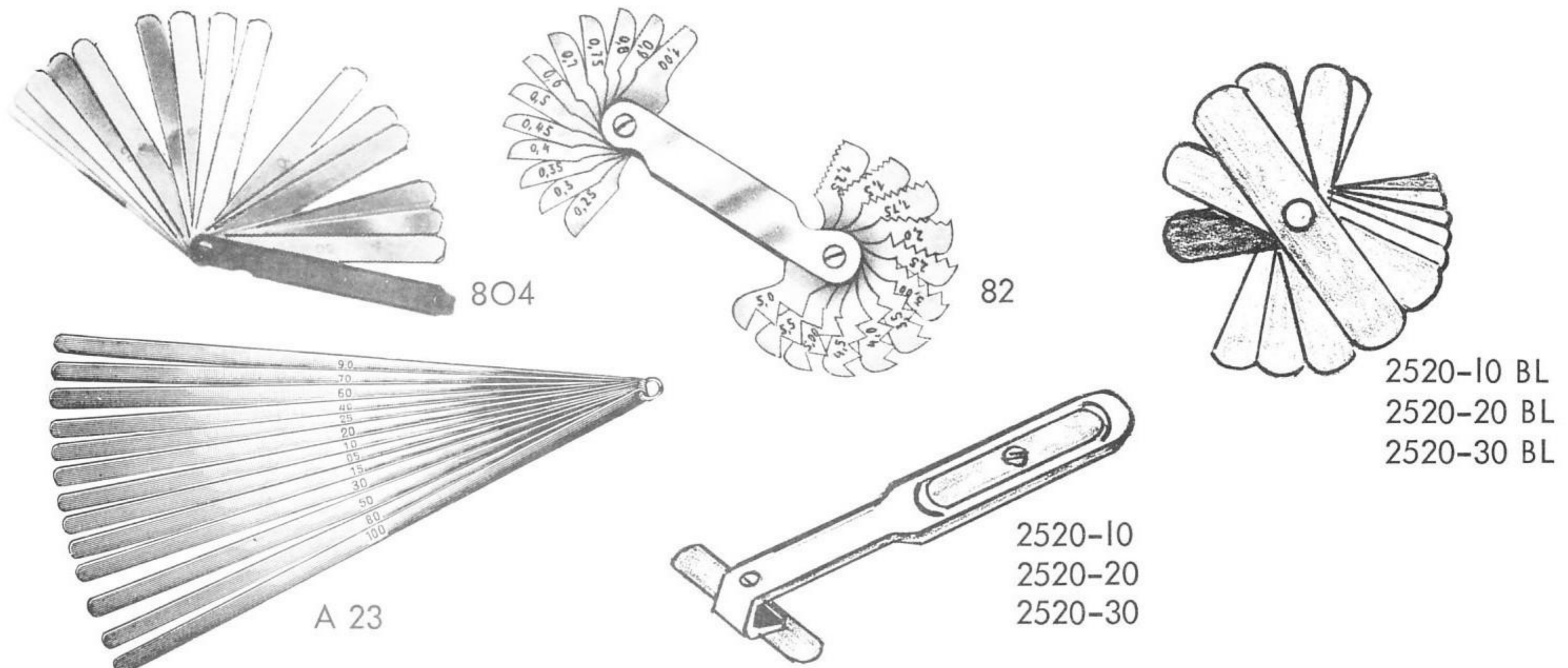

Special **TOOLS**

measuring tools

CATALOG NO.	D E S C R I P T I O N	NET PRICE US \$	REMARKS
<u>VERNIER CALIPERS AND DEPTH GAGES</u>			
S 5	PRECISION POCKET VERNIER CALIPER ,Special Alloy tool steel-hardened.Scale length 160 mm(6").Reading on the upper scale 1/125",Reading on lower scale 1/20 mm.		
SR 14	STAINLESS STEEL SATIN CHROMED HIGH PRECISION POCKET VERNIER CALIPER.Hardened. Scale length 160mm(6")Reading:upper scale 1/20mm,lower scale 1/1000".		
S 57	PRECISION VERNIER CALIPER WITH FINE ADJUSTMENT Graduated in metric & inch systems.Scale length 300mm (12")Reading: upper scale 1/50mm,lower scale in inch decimals.		
S 18	METRIC DEPTH GAUGE. Scale length 300 mm (12") Length of head 220 mm		Used on Gear Box
S 113	PRECISION WORKSHOP VERNIER DEPTH GAGE with hook.Measuring capacity 250 mm (10") Reading in 1/50 mm		
S 124	PRECISION VERNIER DEPTH GAGE With fine adjustment.Measuring capacity 250 mm (10") Reading in 1/50 mm		
<u>STEEL TAPE AND STEEL RULES</u>			
N 3 - 500	WORKSHOP RULE,QUALITY I. LENGTH 500 mm. Width 30 mm,Thickness 6 mm.Working edges finely scraped.Flats best machined.		
R 200	STAINLESS STEEL FLEXIBLE RULE ,Length 200 mm Both sides graduated in mm & inches.		
R 300	STAINLESS STEEL FLEXIBLE RULE,Length 300 mm Both sides graduated in mm & inches.		
R 500	STAINLESS STEEL FLEXIBLE RULE,Length 500 mm Both sides graduated in mm and inches.		
S 167	STEEL TAPE MEASURE,Length 2 meters,Width 13 mm For inside and outside measurements In molded zinc case.		

ILLUSTRATIONS ON PAGE: 101

Special**TOOLS**

precision measuring instruments

CATALOG No.	D E S C R I P T I O N	NET PRICE US\$	REMARKS
M I C R O M E T E R S			
M 16 0-25	PRECISION MICROMETER Measuring capacity : 0-25 mm. In Wooden Case.		
M 16 25-50	PRECISION MICROMETER. Measuring Capacity:25-50 mm. With Checking Standard. In Wooden Case.		
M 16 50-75	PRECISION MICROMETER. Measuring Capacity:50-75 mm. With Checking Standard. In Wooden Case.		
M 16 75-100	PRECISION MICROMETER. Measuring Capacity:75-100 mm. With Checking Standard. In Wooden Case.		
B O R E G A G E S			
UG 74 - 3	SELF-CENTERING HIGH PRECISION FINE BORE GAGE "SUBITO". Reading : 1/100 mm.Measuring capacity 18-100mm. WITH DIAL GAGE. With 3 Measuring Bars. In Wooden Case.		Recommended by VWoA
UG 74 - 2	SELF-CENTERING HIGH PRECISION FINE BORE GAGE "SUBITO". Measuring capacity: 50- 100 mm. Reading 1/100 WITH DIAL GAGE. With 1 Measuring Bar. In Wooden Case.		

ILLUSTRATIONS ON PAGE: 102

**Special TOOLS****precision measuring instruments****DIAL INDICATORS**

CATALOG No.	DESCRIPTION	NET PRICE US\$	REMARKS
U - 11	METRIC DIAL INDICATOR Normal Size. Diameter 58 mm (2-1/4") Reading 0.01 mm, Travel 11 mm.		
U - 2	METRIC DIAL INDICATOR Small Size. Diameter 39 mm. (1-1/2") Reading 0.01 mm, Travel 5 mm.		
EXTENSIONS:			
E - 3	DIAL INDICATOR EXTENSION, Length 3 mm Shorter than standard.		
E - 6	DIAL INDICATOR EXTENSION, Length 6 mm, Standard		
E - 14	DIAL INDICATOR EXTENSION, Length 14 mm.		
E - 18	DIAL INDICATOR EXTENSION, Length 18 mm.		
E - 21	DIAL INDICATOR EXTENSION, Length 21 mm.		
E - 28	DIAL INDICATOR EXTENSION, Length 28 mm.		
E - 6 T	DIAL INDICATOR EXTENSION, Length 6 mm. Flat,		#382 Tool
E - 18 T	DIAL INDICATOR EXTENSION, Length 18 mm.		#382 Tool
E - 22 T	DIAL INDICATOR EXTENSION, Length 22 mm. Tapered		#381 Tool
E - 30 T	DIAL INDICATOR EXTENSION, Length 30 mm. Tapered		#383-9 Tool
E - 52 T	DIAL INDICATOR EXTENSION, Length 52 mm. Tapered		#381 Tool
E - 85 T	DIAL INDICATOR EXTENSION, Length 85 mm.		#381-12 Tool

T= Tracer

ILLUSTRATIONS ON PAGE: 102



Special TOOLS

CARBON STEEL HAND TAPS AND DIES



HAND TAPS SETS OF 3 PCS

ROUND DIES

DIA & PITCH	DRILL SIZE DIA mm	NET PRICE US \$	REMARKS	DIA & PITCH	O.D. INCHES	NET PRICE US \$	REMARKS
M 4 x 0.70	3.3			M 4 x 0.70	1		
M 5 x 0.80	4.2			M 5 x 0.80	1		
M 6 x 1.00	5			M 6 x 1.00	1		
M 7 x 1.00	6			M 7 x 1.00	1		
M 8 x 1.25	6.7			M 8 x 1.25	1		
M 8 x 1.00	7			M 8 x 1.00	1		
M10 x 1.50	8.5			M10 x 1.50	1		
M10 x 1.25	8.75			M10 x 1.25	1		
M10 x 1.00	9			M10 x 1.00	1		
M12 x 1.75	10.2			M12 x 1.75	1-1/2		
M12 x 1.50	10.5			M12 x 1.50	1-1/2		
M12 x 1.00	11			M12 x 1.00	1-1/2		
M14 x 2.00	12			M14 x 2.00	1-1/2		
M14 x 1.50	12.5			M14 x 1.50	1-1/2		
M14 x 1.25	12.75			M14 x 1.25	1-1/2		
				M16 x 1.50	1-1/2		
				M16 x 1.50 L.H.	1-1/2		
				M18 x 1.00	1-1/2		
				M18 x 1.00 L.H.	1-1/2		
				M18 x 1.50	1-1/2		
				M18 x 1.50 L.H.	1-1/2		
				M22 x 1.50	1-3/4		
				M22 x 1.50 L.H.	1-3/4		
				M24 x 1.50	1-3/4		
				M30 x 1.50	2		



HIGH SPEED GROUND THREAD PLUG TAPS

M15 x 1.50	13.5		
M20 x 1.50	18.5		
M28 x 1.50	26.5		



TAP WRENCHES



DIE STOCKS

TOOL No	CAPACITY FOR TAPS DIA mm	NET PRICE US \$	REMARKS	TOOL No	CAPACITY O.D. DIES	NET PRICE US \$	REMARKS
10 - 1	2 to 6			12 - 2	1"		
10 - 2	4 to 14			12 - 3	1-1/2"		
10 - 3	5 to 18			12 - 4	1-3/4"		
COMPLETE TAP & DIE SET SEE NEXT PAGE				12 - 5	2"		

Special**TOOLS**

METRIC TAP AND DIE SET

IN WOODEN BOX

SET CONSISTS OF:

HAND TAPS-SETS OF 3 Pcs

- M 6 x 1.00
- M 7 x 1.00
- M 8 x 1.25
- M 8 x 1.00
- M 10 x 1.50
- M 10 x 1.00
- M 12 x 1.50
- M 14 x 1.50

ONE TAP

- M 14 x 1.25

ONE TAP WRENCH

- No.10 size 2

ROUND DIES

- M 6 x 1.00
- M 7 x 1.00
- M 8 x 1.25
- M 8 x 1.00
- M 10 x 1.50
- M 10 x 1.00
- M 12 x 1.50
- M 16 x 1.50
- M 16 x 1.50 L.H.
- M 18 x 1.50
- M 18 x 1.50 L.H.
- M 18 x 1.00
- M 18 x 1.00 L.H.
- M 22 x 1.50
- M 22 x 1.50 L.H.
- M 24 x 1.50
- M 30 x 1.50

DIE STOCKS

- No.12 size 2
- No.12 size 3
- No.12 size 4
- No.12 size 5

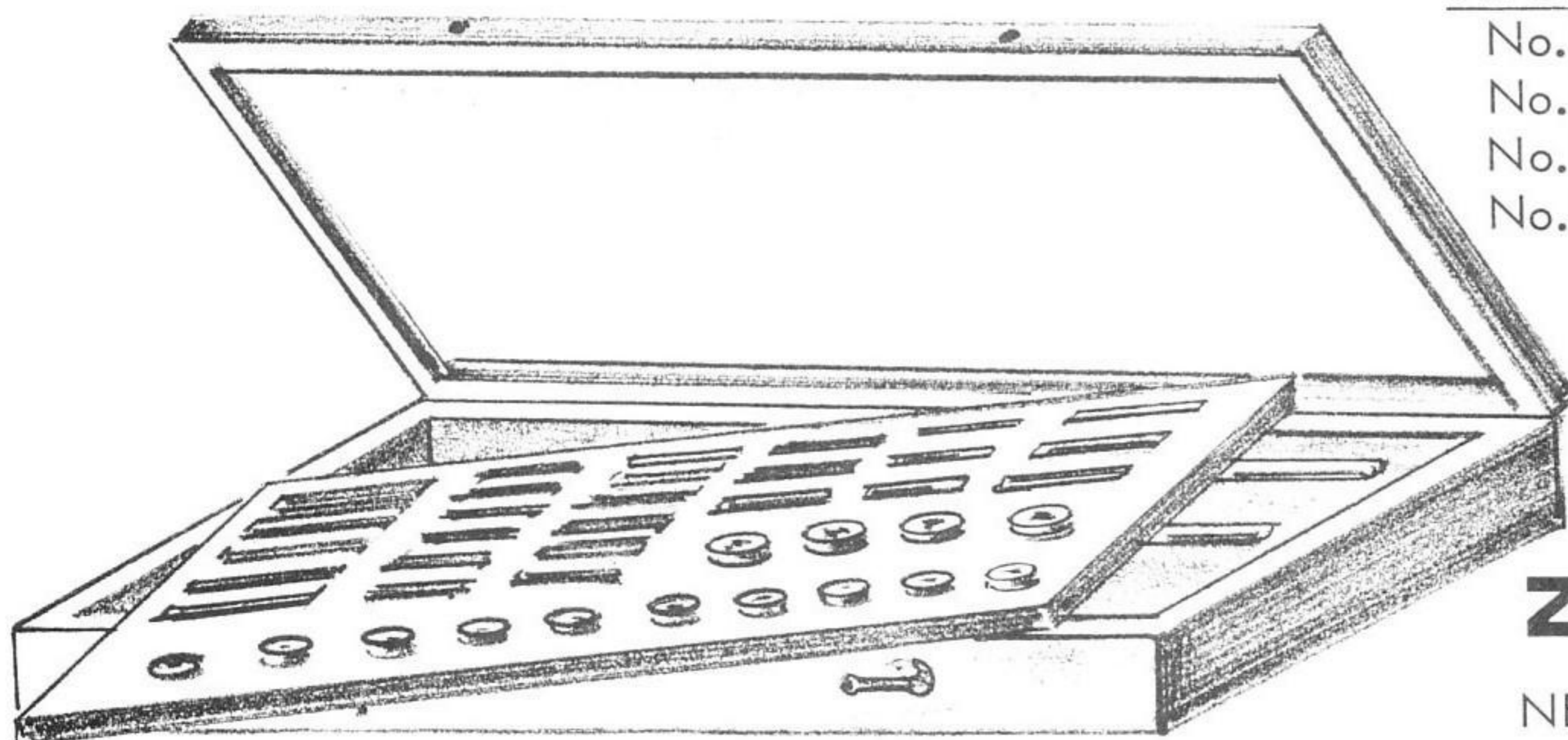

Z - TD 47

NET PRICE US \$

Special **TOOLS**



METRIC DRILLS

SUPER HIGH SPEED STEEL

DIA mm	OVERALL LENGTH	NET PRICE	REMARKS	DIA mm	OVERALL LENGTH	NET PRICE	REMARKS	DIA mm	OVERALL LENGTH	NET PRICE	REMARKS
MINIMUM ORDER \$ 5.00											
0.50	36			3.10	67			7.00	100		
0.55	36			3.20	67			7.10	105		
0.60	36			3.25	67			7.20	105		
0.65	36			3.30	67			7.25	105		
0.70	36			3.40	67			7.30	105		
0.75	36			3.50	75			7.40	105		
0.80	36			3.60	75			7.50	110		
0.85	36			3.70	75			7.60	110		
0.90	36			3.75	75			7.70	110		
0.95	36			3.80	75			7.75	110		
1.00	44			3.90	75			7.80	110		
1.05	44			4.00	79			7.90	110		
1.10	44			4.10	79			8.00	115		
1.15	44			4.20	79			8.10	115		
1.20	44			4.25	79			8.20	115		
1.25	44			4.30	79			8.25	115		
1.30	44			4.40	79			8.30	115		
1.35	44			4.50	85			8.40	115		
1.40	52			4.60	85			8.50	120		
1.45	52			4.70	85			8.60	120		
1.50	52			4.75	85			8.70	120		
1.55	52			4.80	85			8.75	120		
1.60	52			4.90	85			8.80	120		
1.65	52			5.00	89			8.90	120		
1.70	52			5.10	89			9.00	125		
1.75	52			5.20	89			9.10	125		
1.80	52			5.25	89			9.20	125		
1.85	52			5.30	89			9.25	125		
1.90	52			5.40	89			9.30	125		
1.95	52			5.50	95			9.40	125		
2.00	55			5.60	95			9.50	130		
2.05	55			5.70	95			9.70	130		
2.10	55			5.75	95			9.75	130		
2.15	55			5.80	95			9.80	130		
2.20	55			5.90	95			9.90	130		
2.25	55			6.00	99			10.00	135		
2.30	55			6.10	99			10.25	135		
2.35	55			6.20	99			10.50	150		
2.40	55			6.25	99			10.75	150		
2.45	55			6.30	99			11.00	150		
2.50	62			6.40	99			11.25	150		
2.60	62			6.50	100			11.50	160		
2.70	62			6.60	100			11.75	160		
2.75	62			6.70	100			12.00	160		
2.80	62			6.75	100			12.50	160		
2.90	62			6.80	100			13.00	160		
3.00	67			6.90	100						

Special **TOOLS**

SUPER HIGH SPEED STEEL METRIC DRILL SETS

SET No.
<u>Z - D 49</u>
<u>Z - D 27</u>

EACH SIZE PACKED SEPARATELY
IN HANG-UP PLASTIC CONTAINER

METRIC DRILL SET - 49 pcs Set NET PRICE US \$

Consisting of:
 3 pieces of each Drill Dia. 1 , 1.5 , 2 , 2.5 , 3 , 3.5 , 4 , 4.5 mm
 2 pieces of each Drill Dia. 5 , 5.5 , 6 , 6.5 , 7 , 7.5 , 8 , 8.5mm
 9 , 9.5 mm
 1 piece of each Drill Dia. 10 , 10.5 , 11 , 11.5 , 12 mm

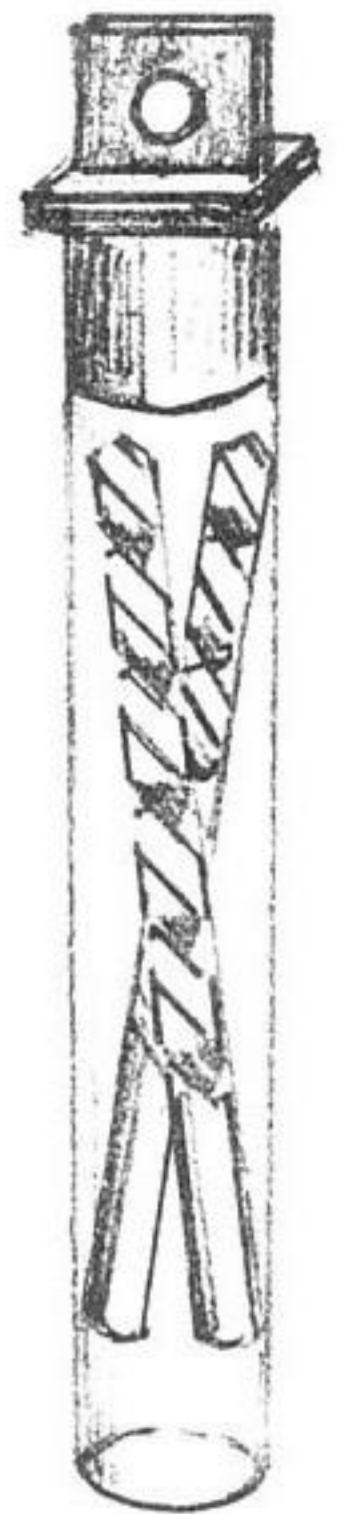

METRIC DRILL SET - 27 pcs Set NET PRICE US \$

Consisting of Metric Drills
 recommended for use with Metric Taps
 3 pieces of each Drill Dia. 3.3 , 4.2 , 4.9 mm
 2 pieces of each Drill Dia. 5.9 , 6.7 , 6.9 , 8.4 , 8.6 , 8.9 mm
 1 piece of each Drill Dia. 10 , 10.25 , 11 , 11.75 , 12 , 12.75 mm

SUPER HIGH SPEED STRAIGHT SHANK TWIST DRILL SETS IN METAL INDEX BOX

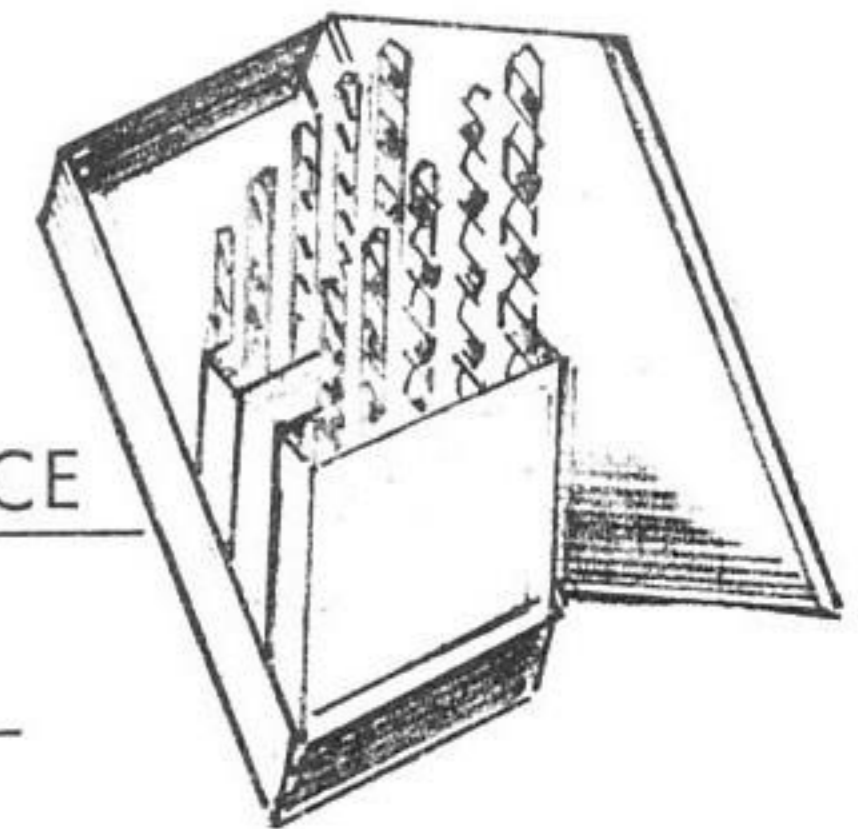

SET No.
<u>1-41A</u>
<u>2-50B</u>
<u>3-50C</u>
<u>4-19D</u>
<u>5-25E</u>

	<u>NET PRICE</u>
41 pieces set from 1 mm to 5 mm (5mm incl.), in steps of 0,1mm. In Metal Index Box.	<u>US \$</u>
50 pieces set from 1 mm to 5.9 mm (5.9 mm incl.) in steps of 0.1 mm. In Metal Index Box.	<u>US \$</u>
50 pieces set from 5.1 mm to 10 mm (10 mm incl.) in steps of 0.1 mm. In Metal Index Box.	<u>US \$</u>
19 pieces set from 1 mm to 10 mm (10 mm incl.) in steps of 0.5 mm. In Metal Index Box.	<u>US \$</u>
25 pieces set from 1 mm to 13 mm (13 mm incl.) in steps of 0.5 mm. In Metal Index Box.	<u>US \$</u>

COMPLETE LISTING OF DRILL SIZES SHOWN ON PAGE 50

Special **TOOLS**

WRENCHES

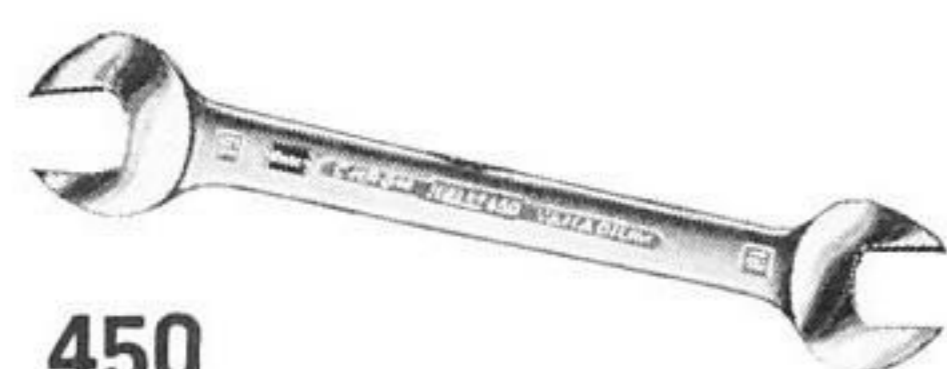
450

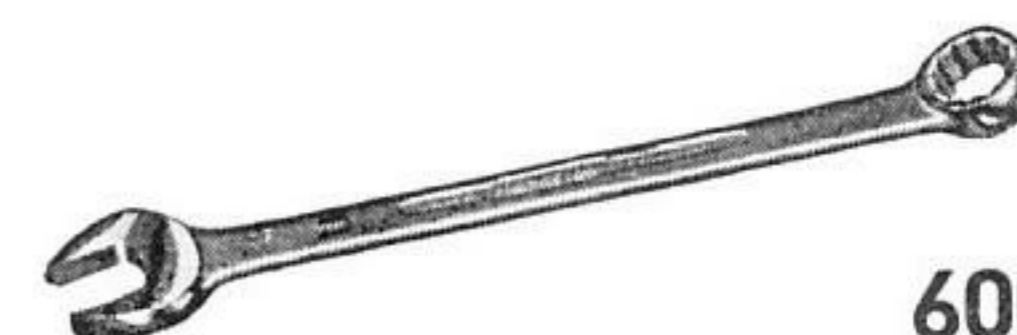
 DOUBLE OPEN-END WRENCHES- HAZET
 CHROME PLATED, BRIGHT HEADS

600

 COMBINATION BOX AND OPEN END
 WRENCHES, CHROME PLATED, BRIGHT HEADS

CATALOG No.	SIZE mm	NET PRICE US \$	REMARKS
450-0045	4 x 5		
450-0067	6 x 7		
450-0089	8 x 9		
450-1011	10 x 11		
450-1213	12 x 13		
450-1415	14 x 15		
450-1617	16 x 17		
450-1819	18 x 19		
450-2022	20 x 22		
450-2123	21 x 23		
450-2426	24 x 26		
450-2528	25 x 28		
450-2730	27 x 30		
450-3236	32 x 36		
450-3842	38 x 42		
450-4146	41 x 46		

ALTERNATE OPENING COMBINATIONS

450-1014	10 x 14
450-1315	13 x 15
450-1417	14 x 17
450-1719	17 x 19

SETS

No.450-0619 7 pieces set NET PRICE US\$ 6 x 7 - 10 x 11 - 14 x 15 - 8 x 9 - 12 x 13 - 16 x 17 - 18 x 19 mm
--

No.600-6719 14pieces set NET PRICE US\$ 6 - 8 - 10 - 12 - 14 - 16 - 18 mm 7 - 9 - 11 - 13 - 15 - 17 - 19 mm

CATALOG No.	SIZE mm	NET PRICE US \$	REMARKS
600-06	6		
600-07	7		
600-08	8		
600-09	9		
600-10	10		
600-11	11		
600-12	12		
600-13	13		
600-14	14		
600-15	15		
600-16	16		
600-17	17		
600-18	18		
600-19	19		
600-20	20		
600-22	22		
600-23	23		
600-24	24		
600-25	25		
600-26	26		
600-27	27		
600-28	28		
600-30	30		
600-32	32		
600-36	36		
600-41	41		

Special **TOOLS**

DOUBLE OFFSET BOX WRENCHES

CHROME - VANADIUM STEEL



No. 625 - 30° Offset



No. 630 - 45° Deep Offset



CATALOG No.	SIZE mm	NET PRICE US \$	REMARKS	CATALOG No.	SIZE mm	NET PRICE US \$	REMARKS
625-0067	6 x 7			630-0067	6 x 7		
625-0089	8 x 9			630-0089	8 x 9		
625-1011	10 x 11			630-1011	10 x 11		
625-1213	12 x 13			630-1213	12 x 13		
625-1415	14 x 15			630-1415	14 x 15		
625-1617	16 x 17			630-1617	16 x 17		
625-1819	18 x 19			630-1819	18 x 19		
625-2022	20 x 22			630-2022	20 x 22		
625-2123	21 x 23			630-2123	21 x 23		
625-2426	24 x 26			630-2426	24 x 26		
625-2528	25 x 28			630-2528	25 x 28		
625-2730	27 x 30			630-2730	27 x 30		
625-3236	32 x 36			630-3236	32 x 36		

SETS

No.625-6719 7 pieces set

DOUBLE OFFSET BOX-END WRENCH SET
 CHROME VANADIUM STEEL
 Chrome Plated-Bright Heads
 6 x 7 mm , 8 x 9 mm , 10 x 11 mm , 12 x 13 mm
 14 x 15 mm , 16 x 17 mm , 18 x 19 mm
 NET PRICE US\$

No.630-6719 7 pieces set

DOUBLE OFFSET BOX-END WRENCH SET
 CHROME VANADIUM STEEL
 Chrome Plated - Bright Heads
 6 x 7 mm , 8 x 9 mm , 10 x 11 mm , 12 x 13 mm
 14 x 15 mm , 16 x 17 mm , 18 x 19 mm
 NET PRICE US\$

Special **TOOLS**

METRIC

SQUARE DRIVE SOCKETS

CHROME-VANADIUM STEEL

3/8"
DRIVE

3/4"
DRIVE

CATALOG No.	OPENINGS mm	NET PRICE US \$	
J 8 H	8		
J 9 H	9		
J 10 H	10		
J 11	11		
J 12	12		
J 13	13		
J 14	14		
J 15	15		
J 16	16		
J 17	17		
J 18	18		
J 19	19		
J 20	20		
J 21	21		

CATALOG No.	OPENINGS mm	NET PRICE US \$	
K 22 H	22		
K 24 H	24		
K 27 H	27		
K 29 H	29		
K 30 H	30		
K 32 H	32		
K 36 H	36		
K 38 H	38		
K 41 H	41		
K 46 H	46		
K 50 H	50		
K 55 H	55		

6 point Sockets

8, 9, 10 mm 6 points, others 12 points.

CATALOG	OPENINGS mm	NET PRICE US \$	
S 10	10		
S 11	11		
S 12	12		
S 13	13		
S 14	14		
S 15	15		
S 16	16		
S 17	17		
S 18	18		
S 19	19		
S 20	20		
S 21	21		
S 22	22		
S 23	23		
S 24	24		
S 25	25		
S 26	26		
S 27	27		
S 28	28		
S 29	29		
S 30	30		
S 32	32		

12 point Sockets

1/2"
DRIVE

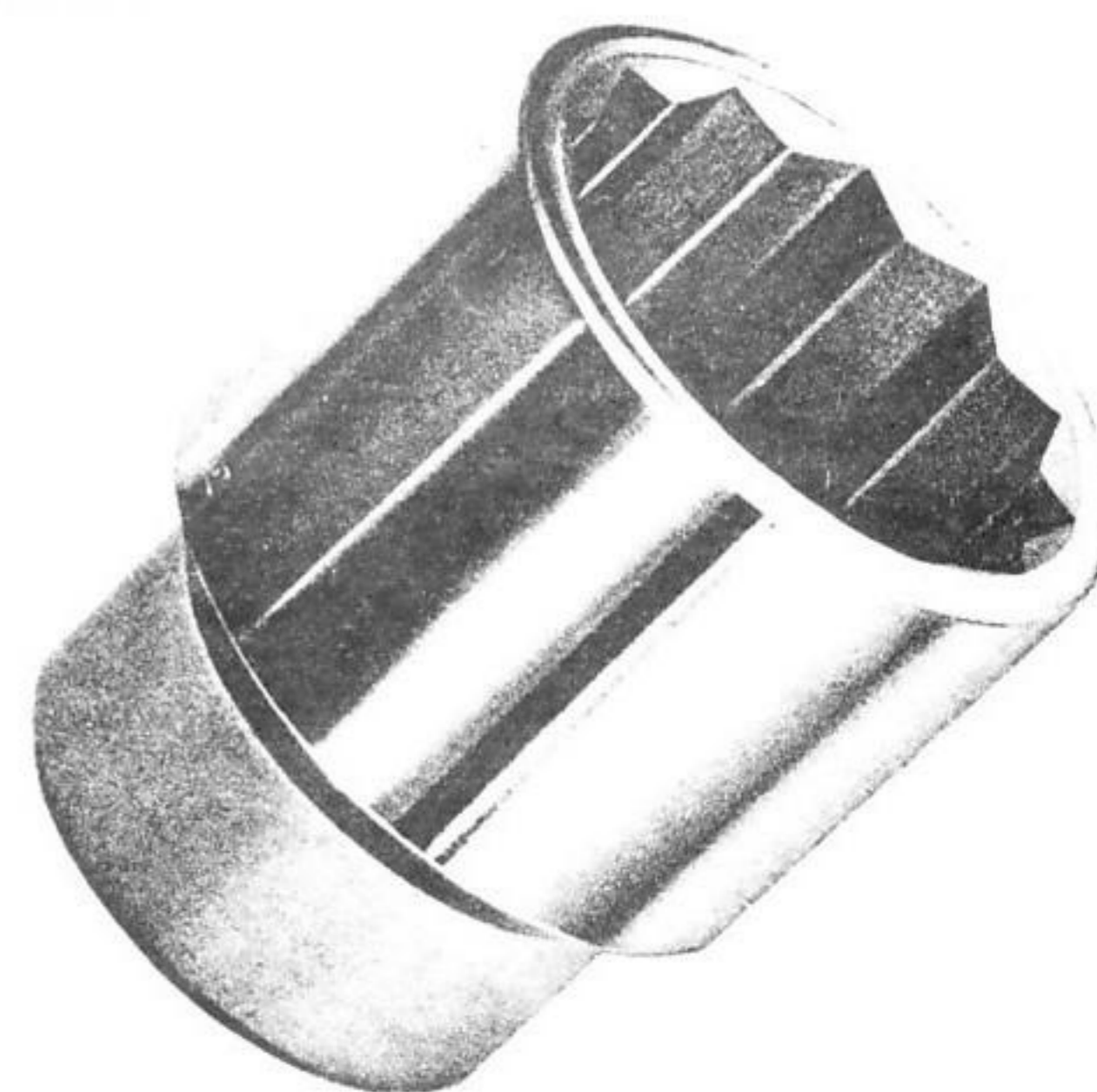

SETS

3/8"

No. J 14 - 8921 METRIC SOCKET SET
NET PRICE 14 Pcs SET
US \$ SIZE 8 to 21 mm

1/2"

No. S 12 - 1021 METRIC SOCKET SET
NET PRICE 12 Pcs SET
US \$ SIZE 10 to 21 mm

1/2"

No. S 22 - 1032 METRIC SOCKET SET
NET PRICE 22 Pcs SET
US \$ SIZE 10 to 32 mm

Special **TOOLS**

VICES

DROP-FORGED STEEL

CATALOG No.	DESCRIPTION				NET PRICE US\$	REMARKS
	JAW WIDTH	OPENING	DEPTH	WEIGHT-Lbs		
<u>HIGH PRECISION MACHINISTS' VISE ON STATIONARY BASE</u>						
5000-3-1/2	3-1/2	4	2-3/8	9		
5000-4-1/2	4-1/2	5	2-3/4	22		
5000-5-1/4	5-1/4	6-3/4	3-1/2	37		
5000-6	6	8	4	57		
5000-7	7	8	4	60		
<u>HIGH PRECISION MACHINISTS' VISE ON SWIVEL BASE</u>						
5001-3-1/2	3-1/2	4	2-3/8	11		
5001-4-1/2	4-1/2	5	2-3/4	26		
5001-5-1/4	5-1/4	6-3/4	3-1/2	44		
5001-6	6	8	4	64		
5001-7	7	8	4	66		
<u>VICE WITH CLAMP ATTACHMENT</u> On Stationary Base						
5002-3-1/2	3-1/2	4	2-3/4	9		
5002-4-1/2	4-1/2	5	2-3/4	22		
5003-5	MULTIPOSITION MACHINISTS' VISE WITH INDEPENDENT SWIVEL AND TILTING SWIVELS 360° HORIZONTALLY AND CAN BE TILTED DOWNWARD 90°. OPENING 5" JAW WIDTH 5", DEPTH 2-3/4". CLAMPING PRESSURE 4500 Lbs.					
5004-4-1/2 5004-5-1/4 5004-6	REINFORCED PLASTIC JAW CAPS-2 PCS SET, 4-1/2" REINFORCED PLASTIC JAW CAPS-2 PCS SET, 5-1/4" REINFORCED PLASTIC JAW CAPS-2 PCS SET, 6"					

"PEDDINGHAUS" - The World's largest producer of DROP-FORGED STEEL VICES

ILLUSTRATIONS ON PAGE No.103

Special TOOLS

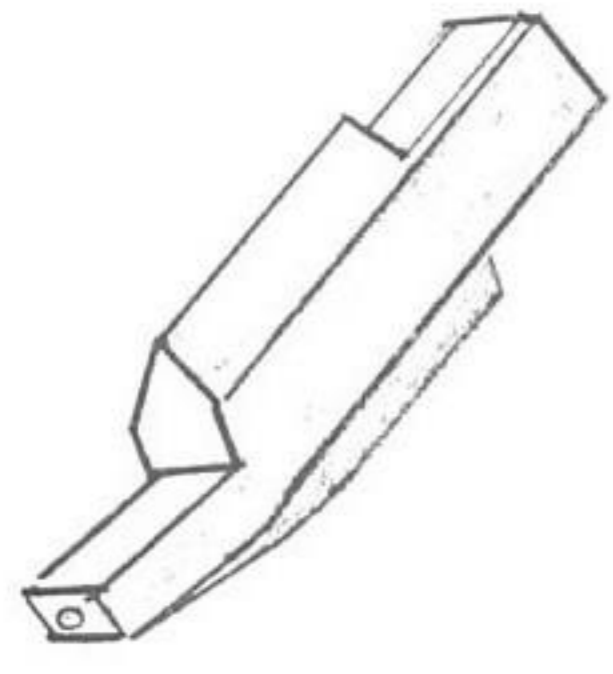

US B-9

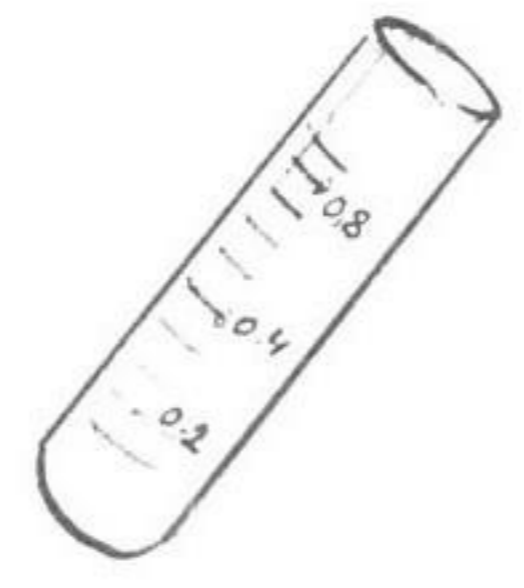

US 8

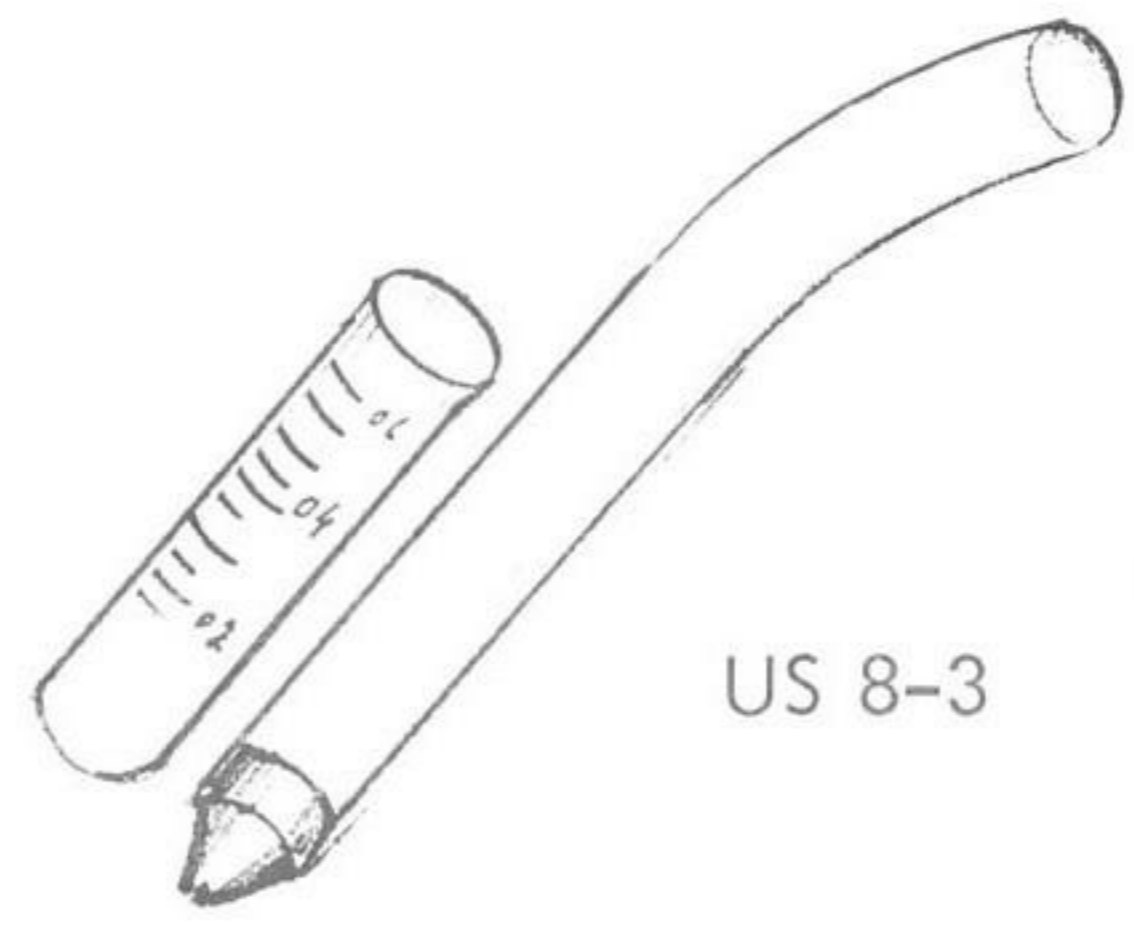

US 8-3

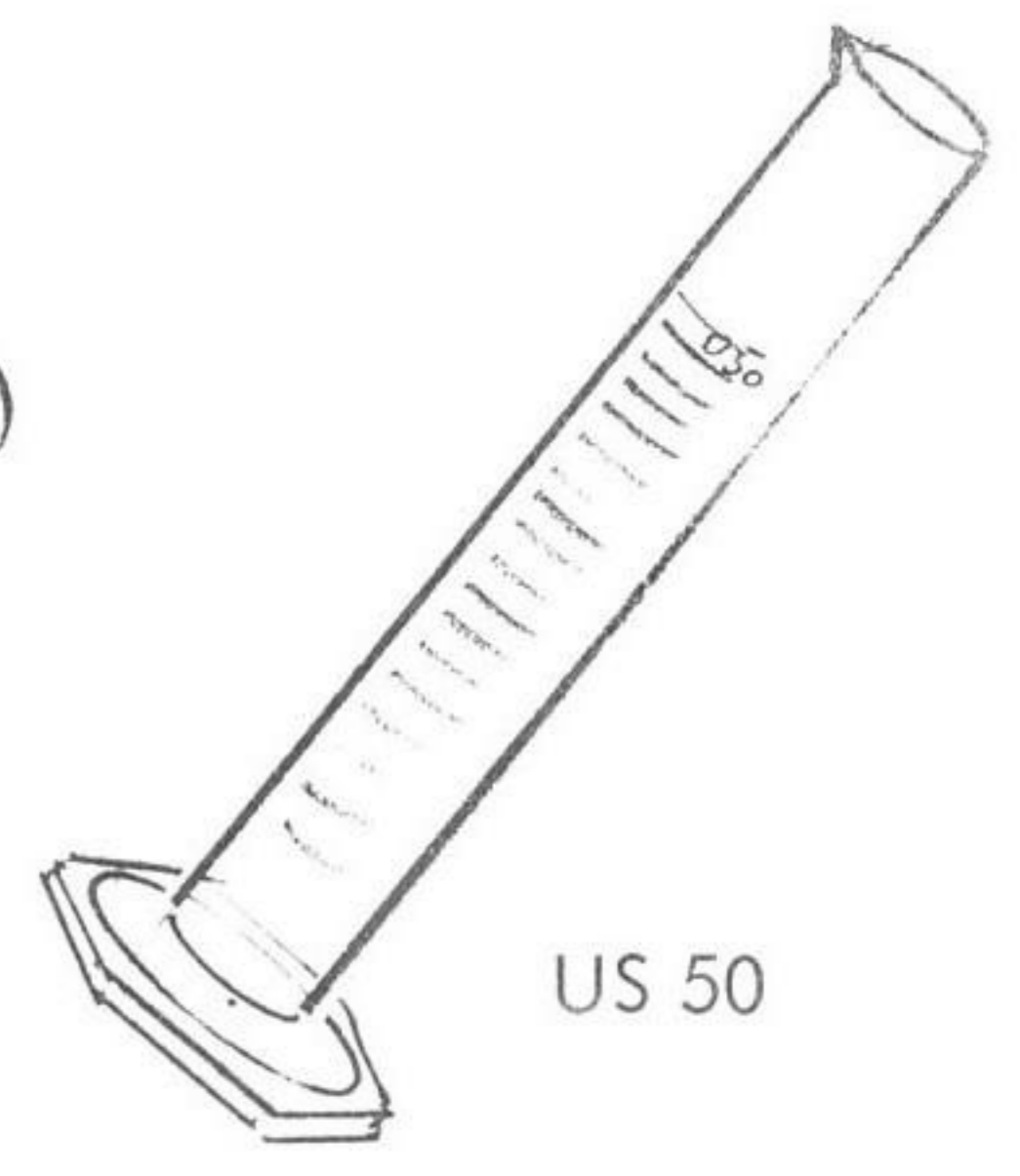

US 50

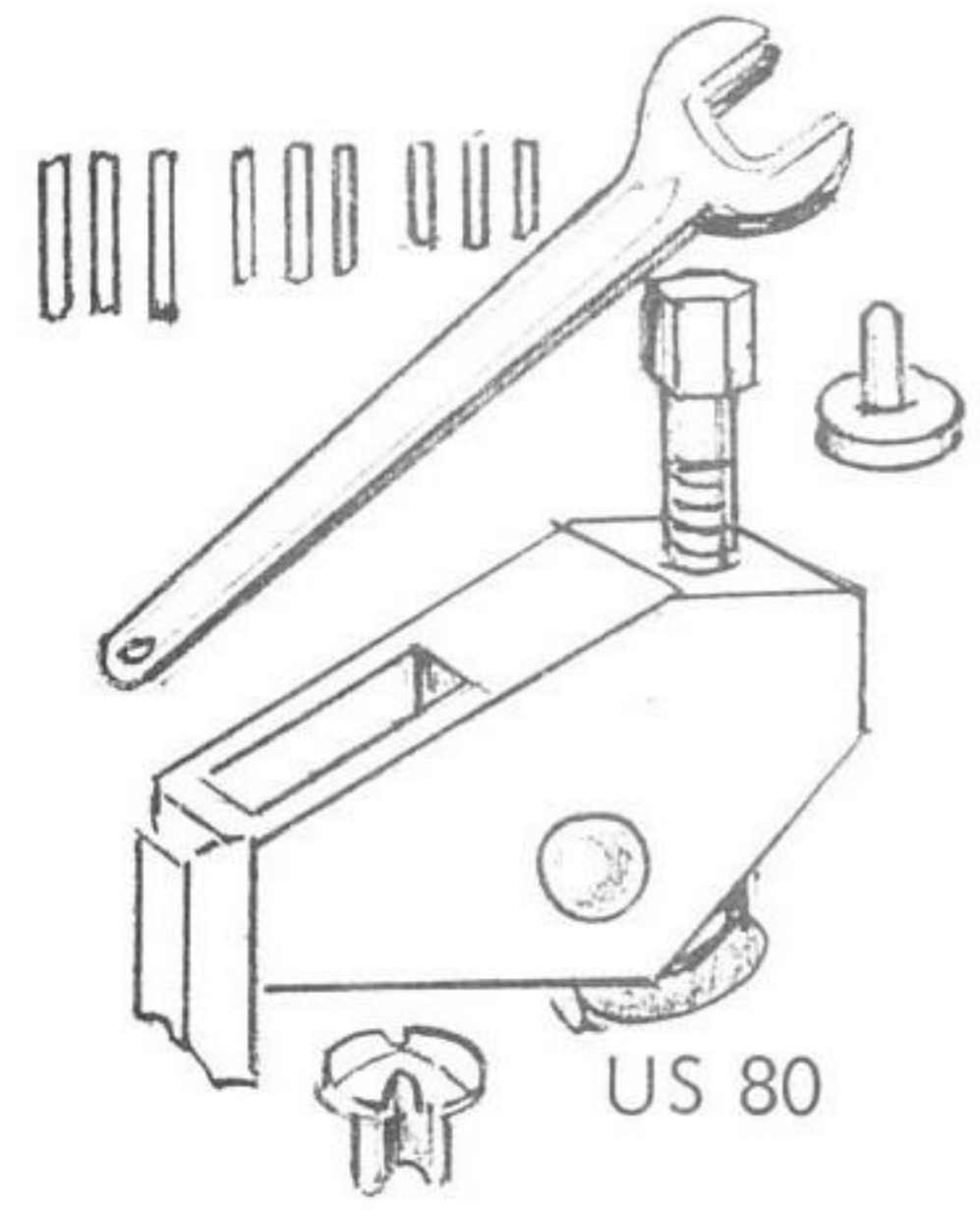

US 80

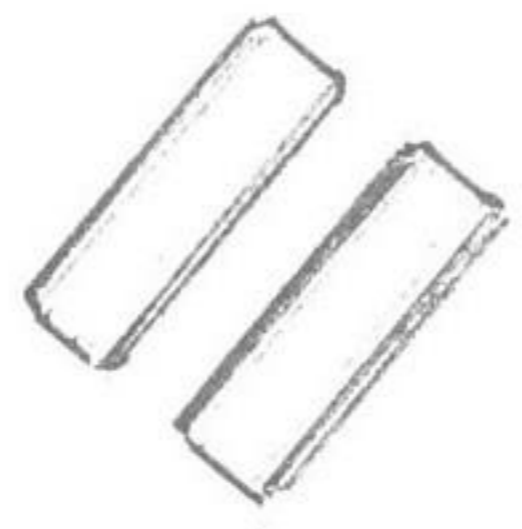

US 80-10



US 80-11



US 80-12

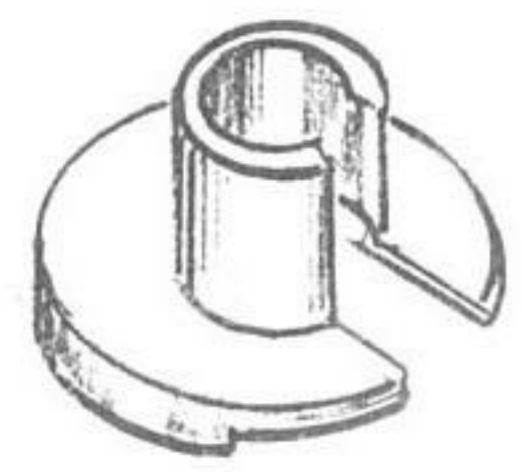

US 80-20

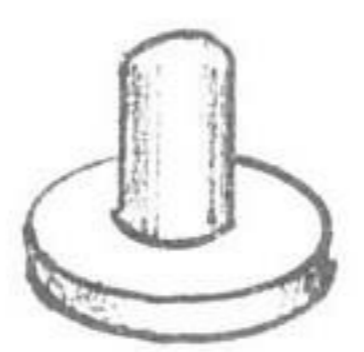

US 80-30

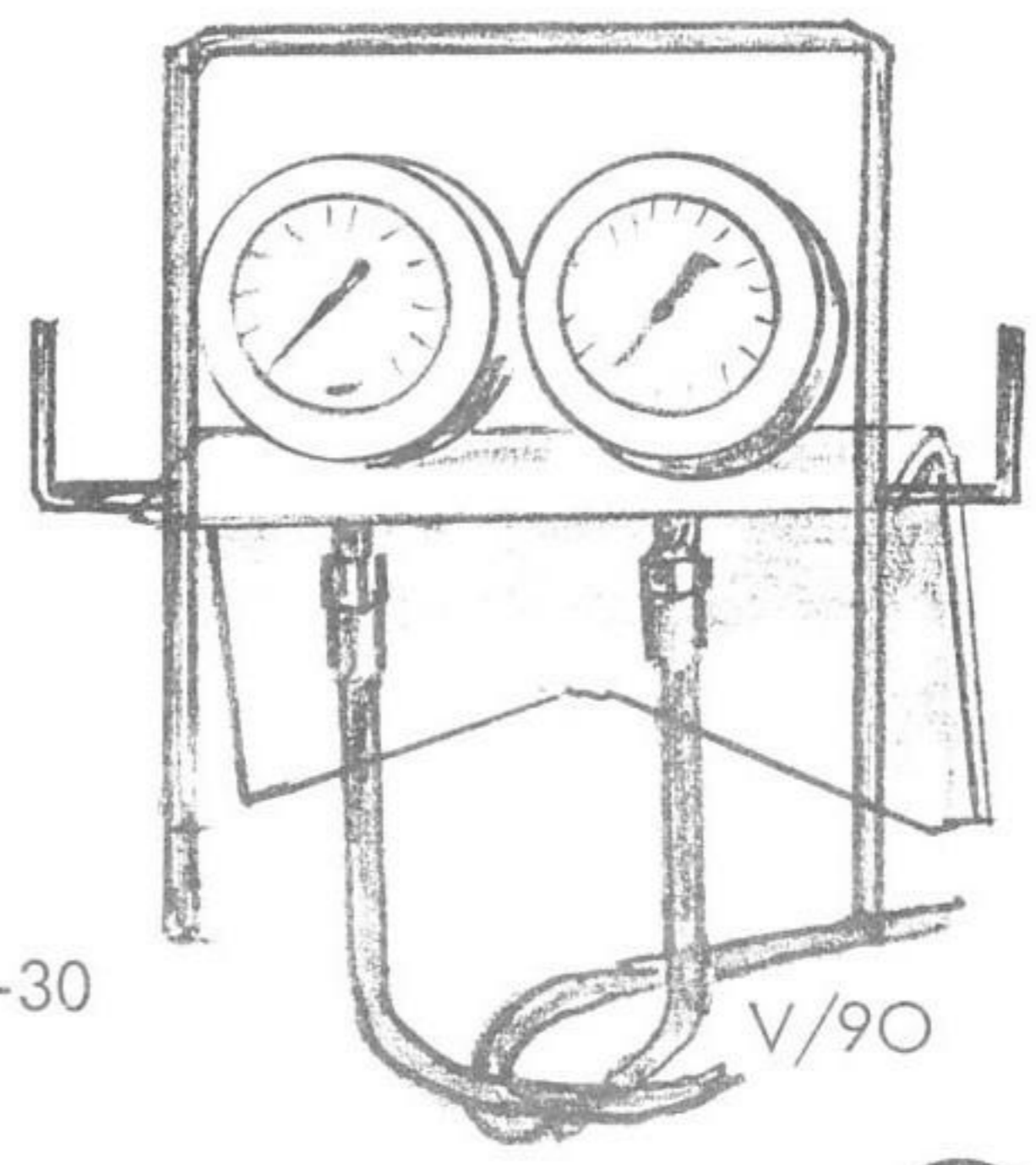

V/90

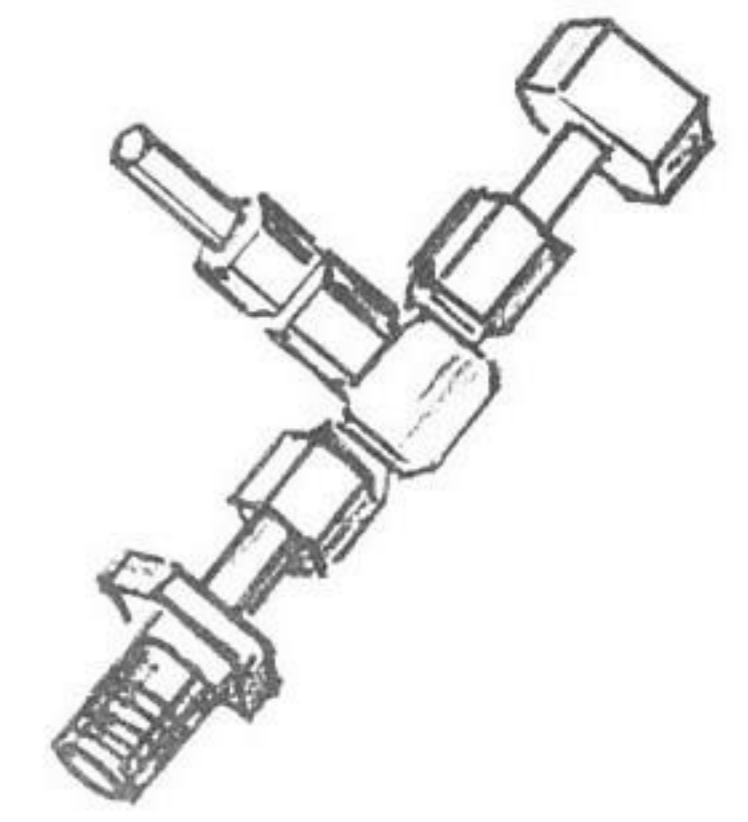

V/90-1

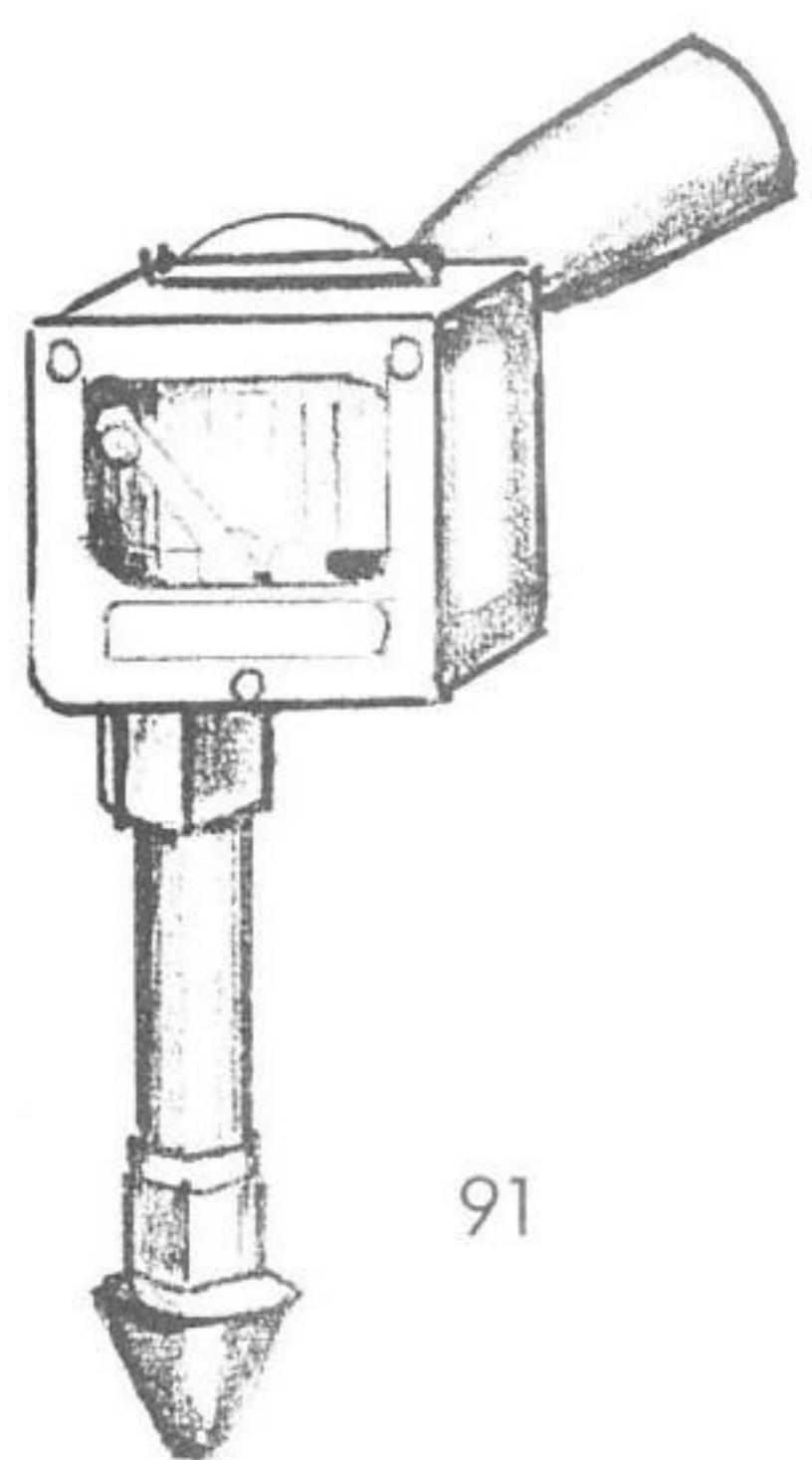

91

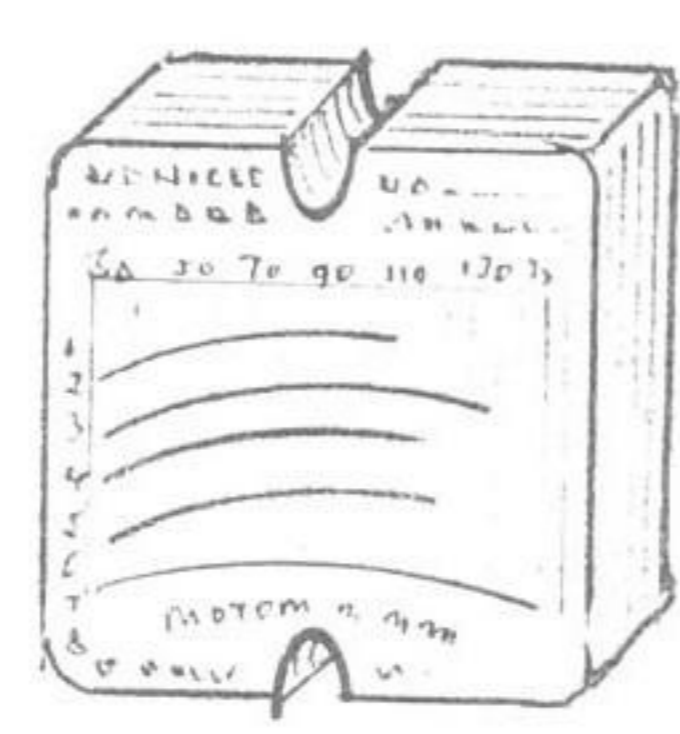

92



93

Special TOOLS



US 101

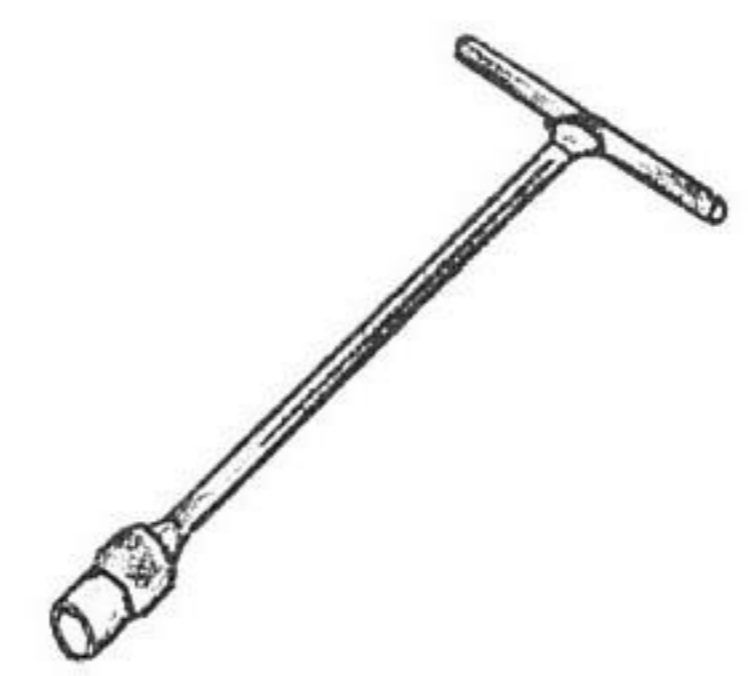

US 102



US 103

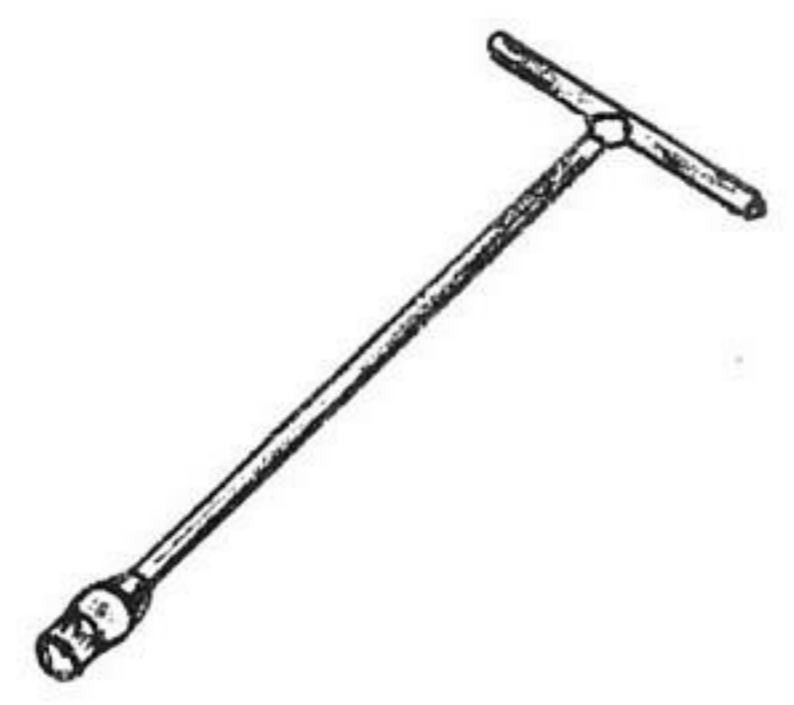

US 106

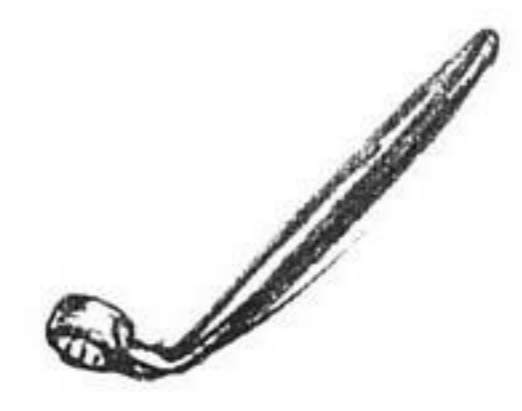

US 109



US 109 H

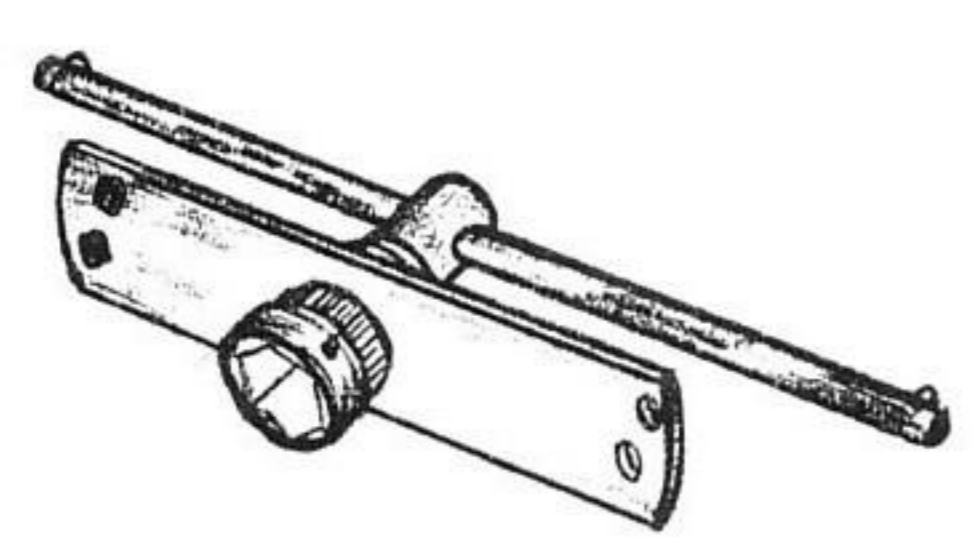

US 112 A

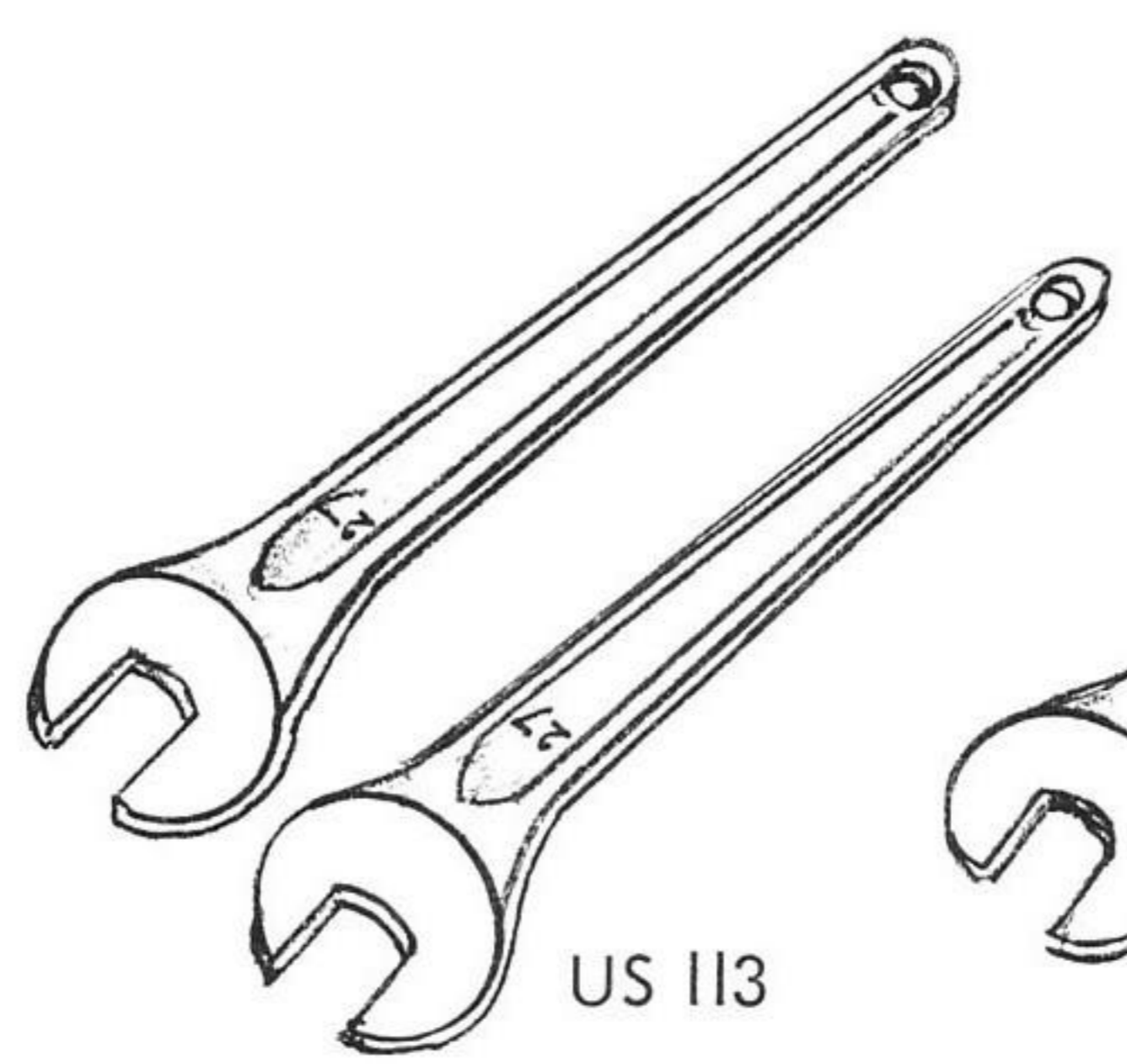

US 113

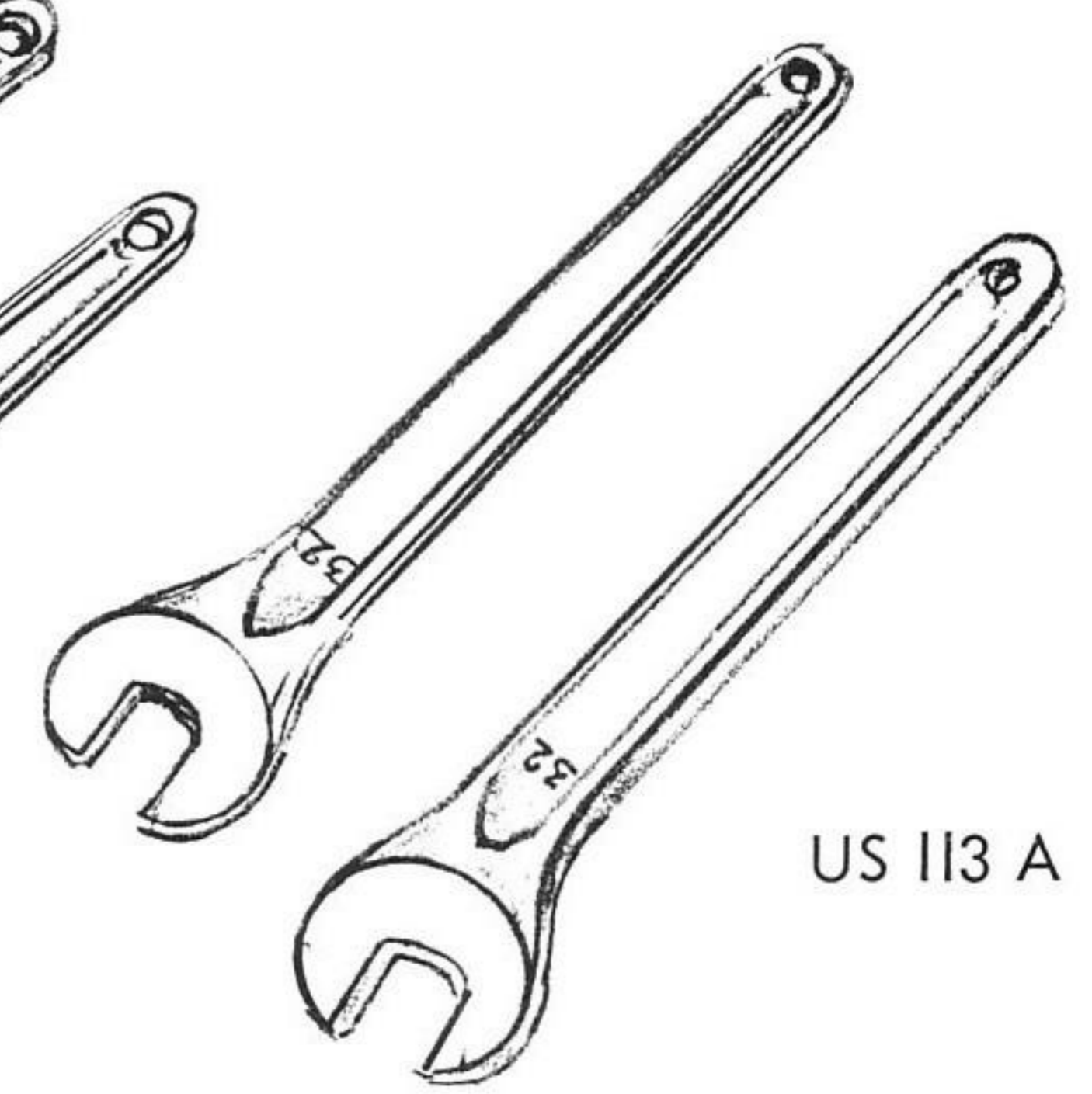

US 113 A

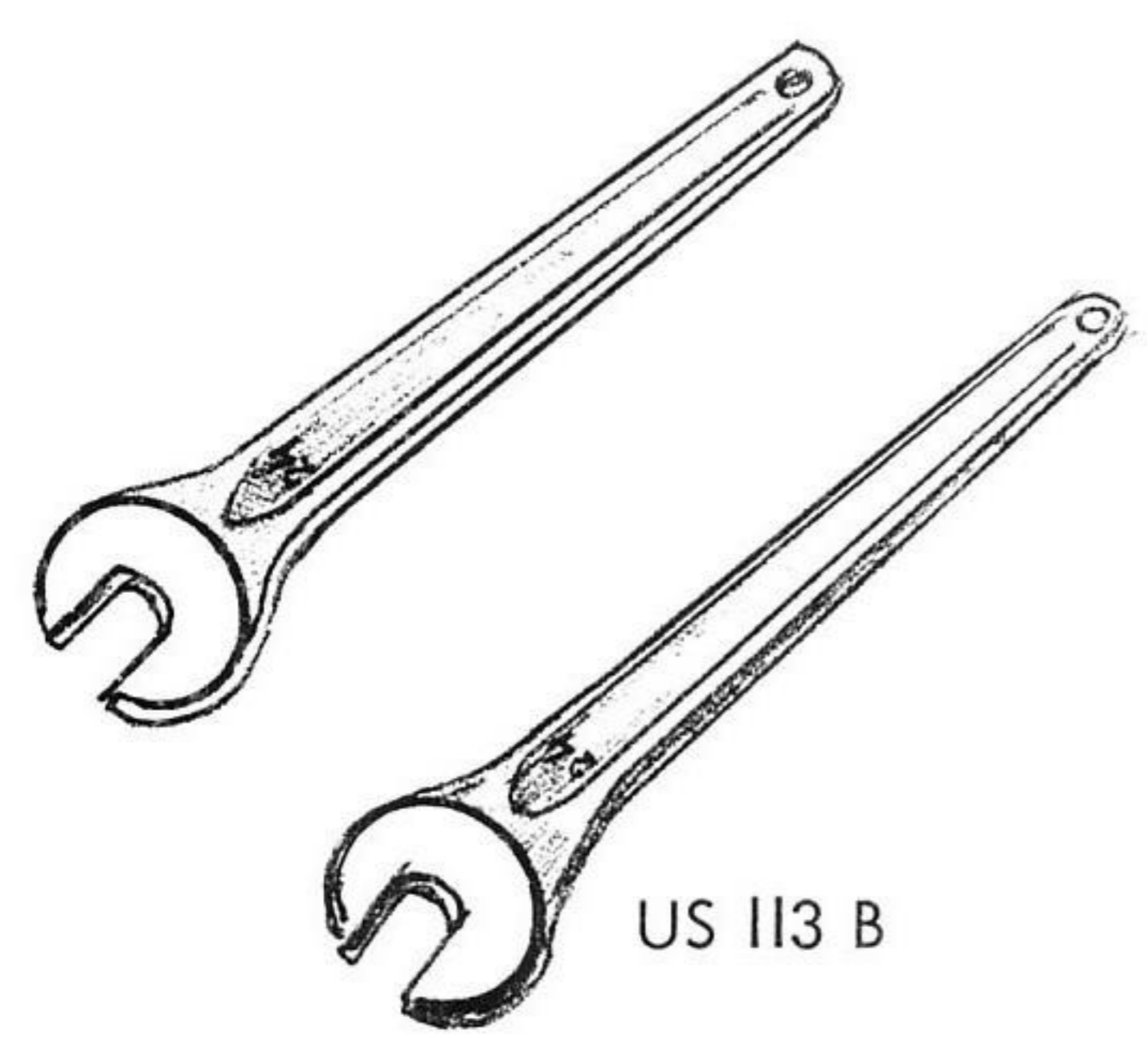

US 113 B

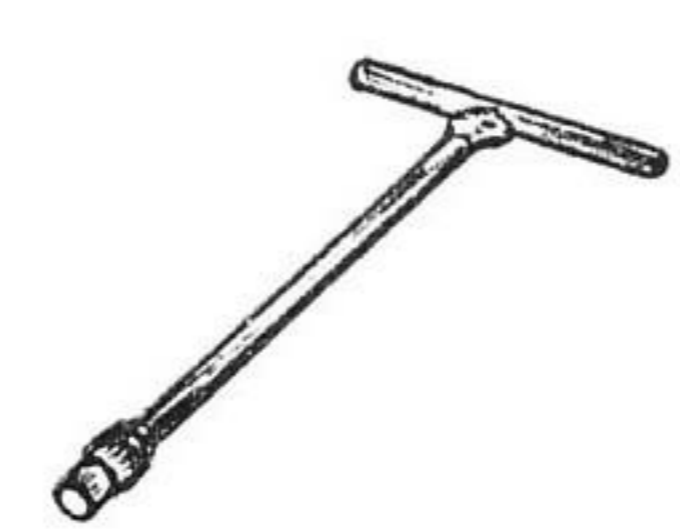

US 114-I

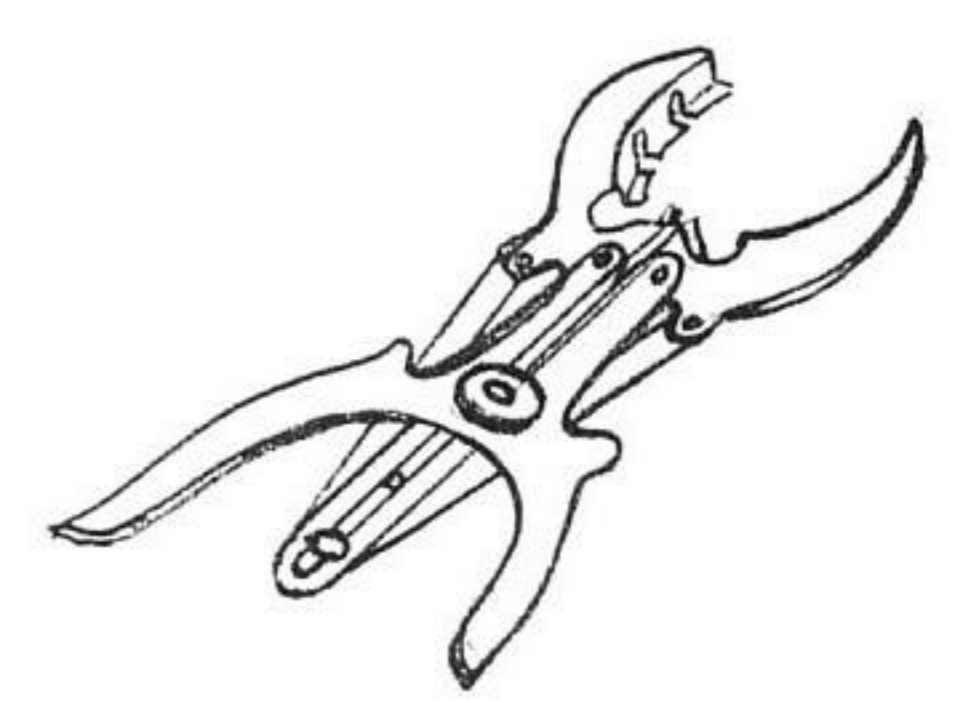

US 121 B

Special TOOLS



US I22 B



US I23

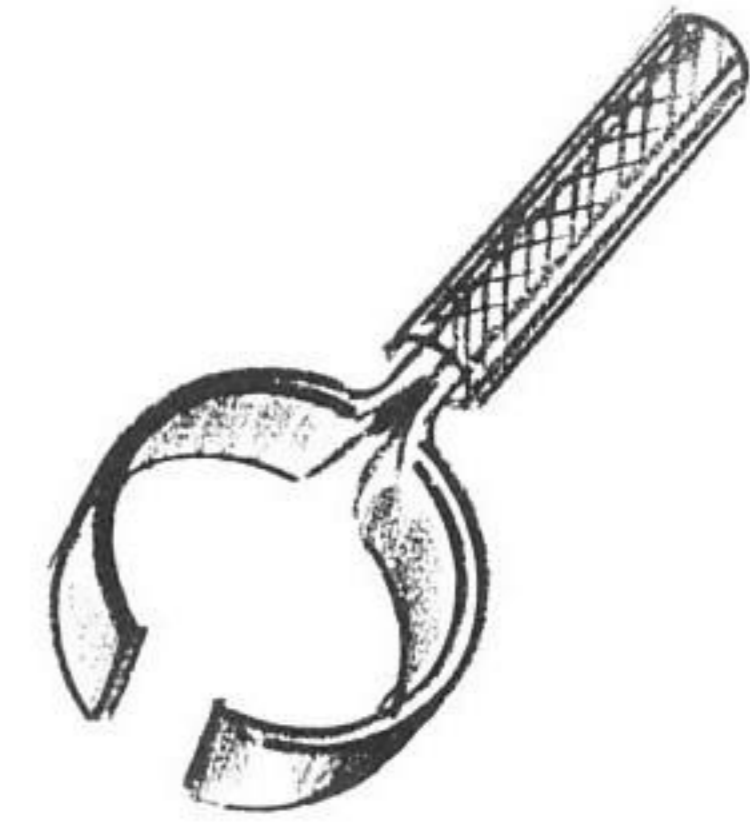

US I23 A



US I23 B



US I23 C



US I24

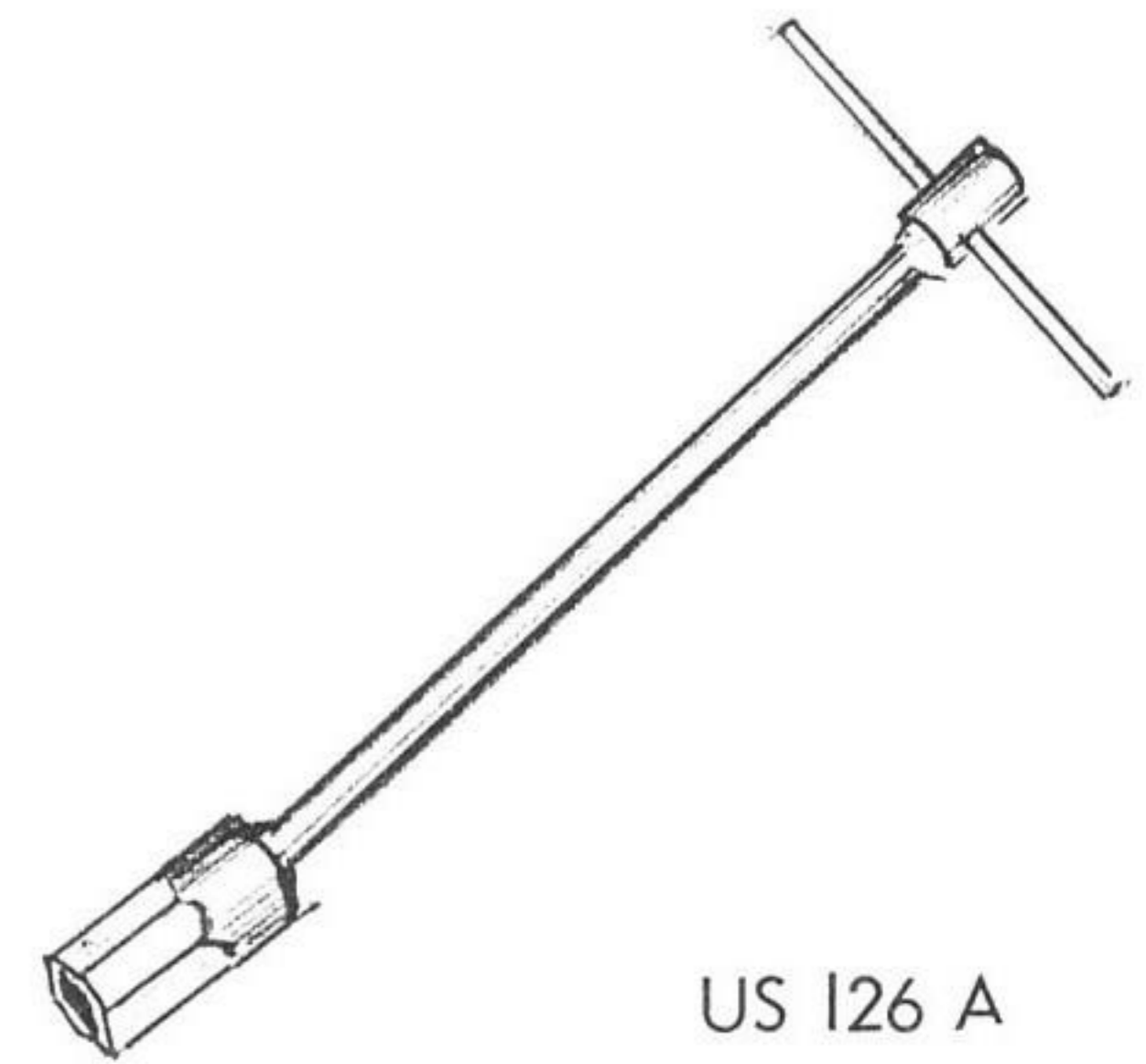

US I26 A

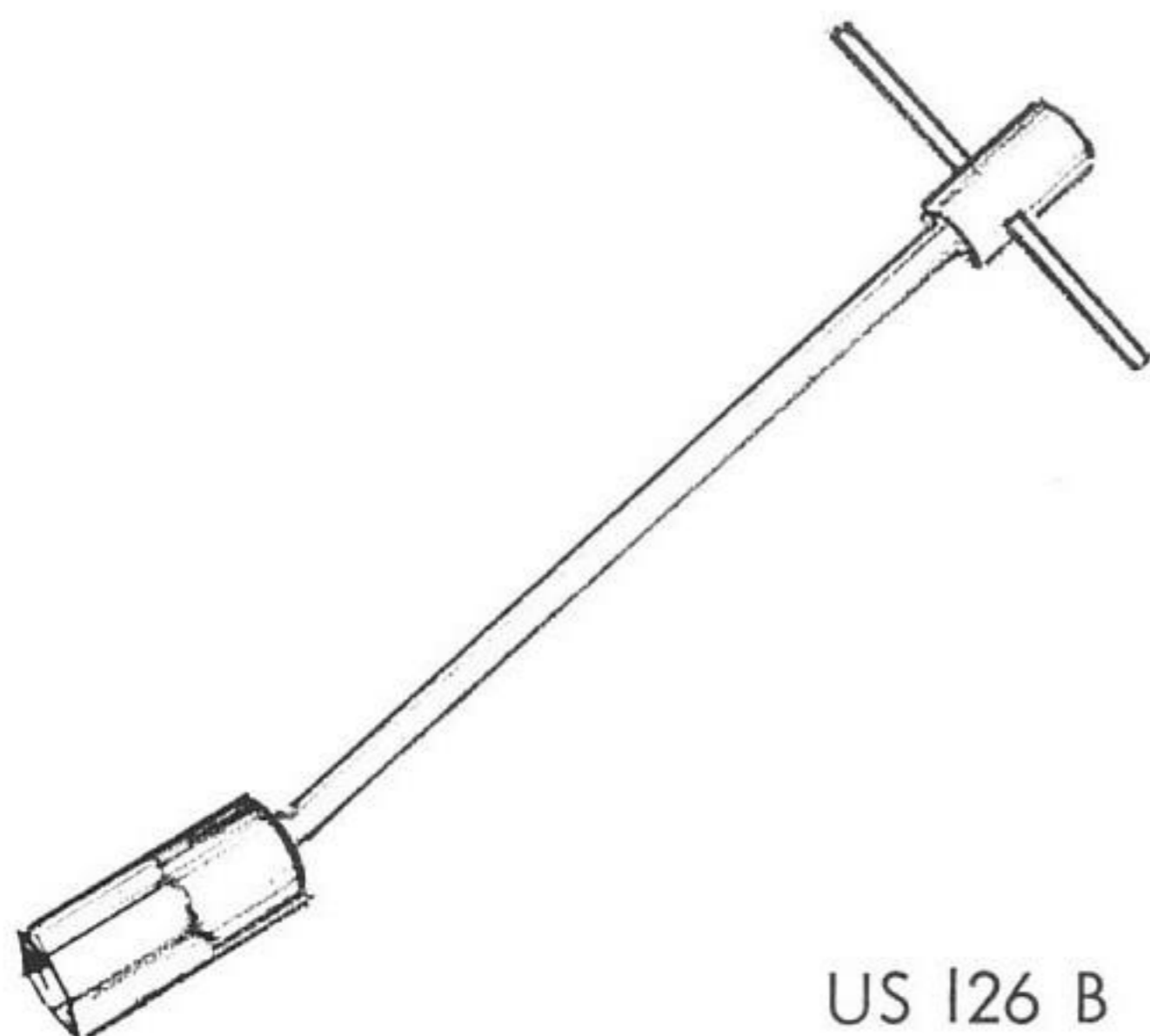

US I26 B



US I30



US I30 A

Special **TOOLS**



US 131



US 131 A



US 133



US 133 A



US 133 B

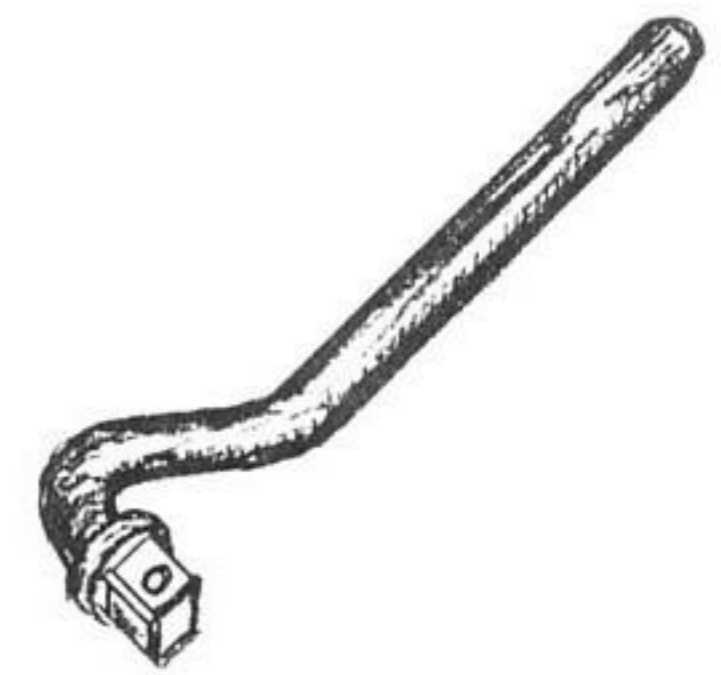

US 150

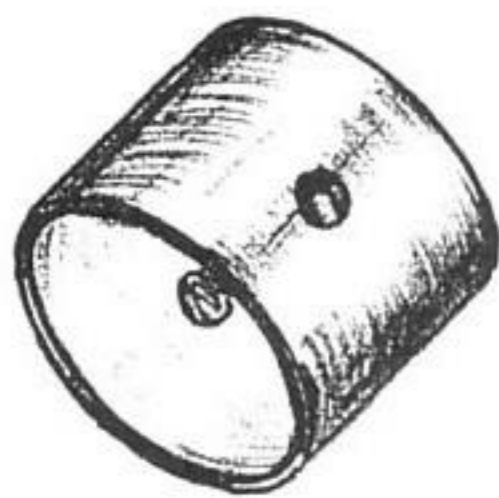

US 151



US 156



US 157

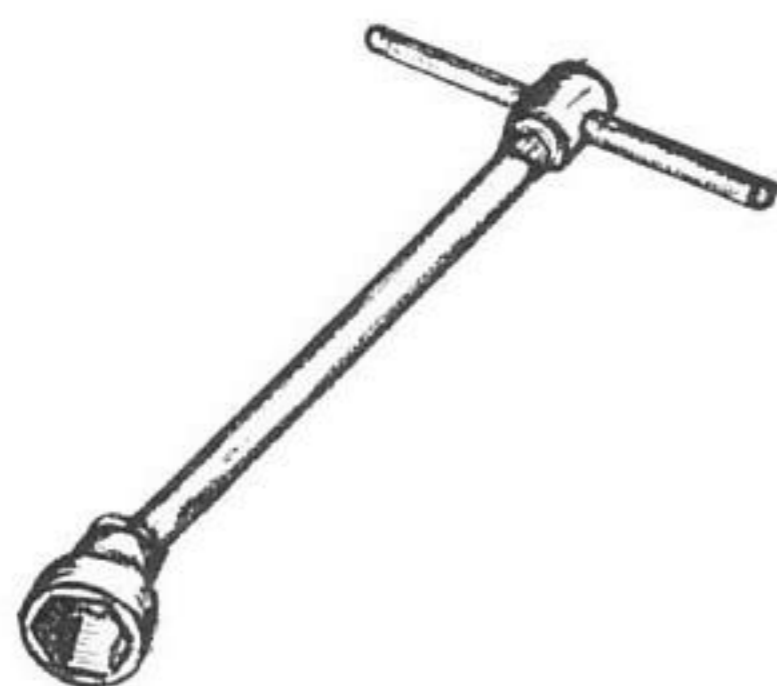

US 159



US 159 A



US 161 A

Special **TOOLS**

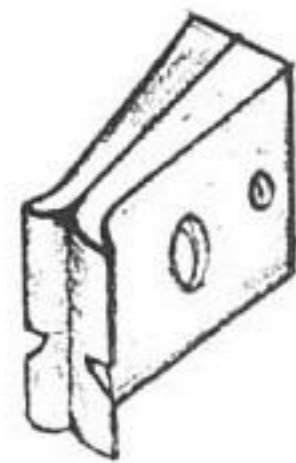

US 161 B

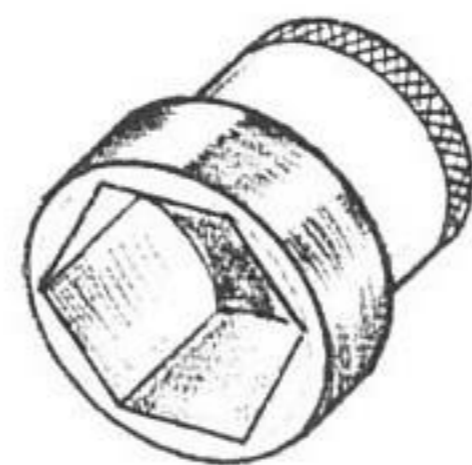

US 162

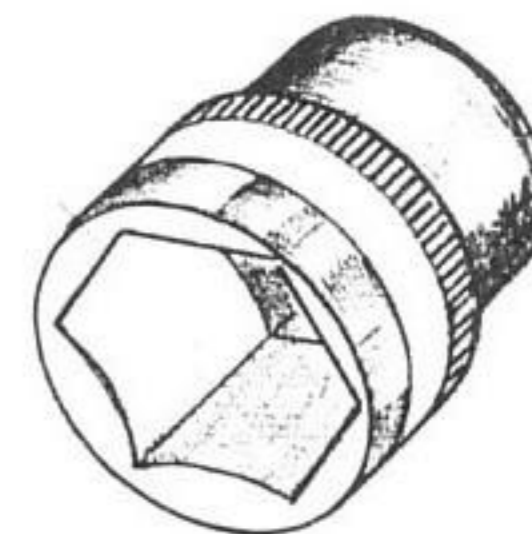

US 163 A

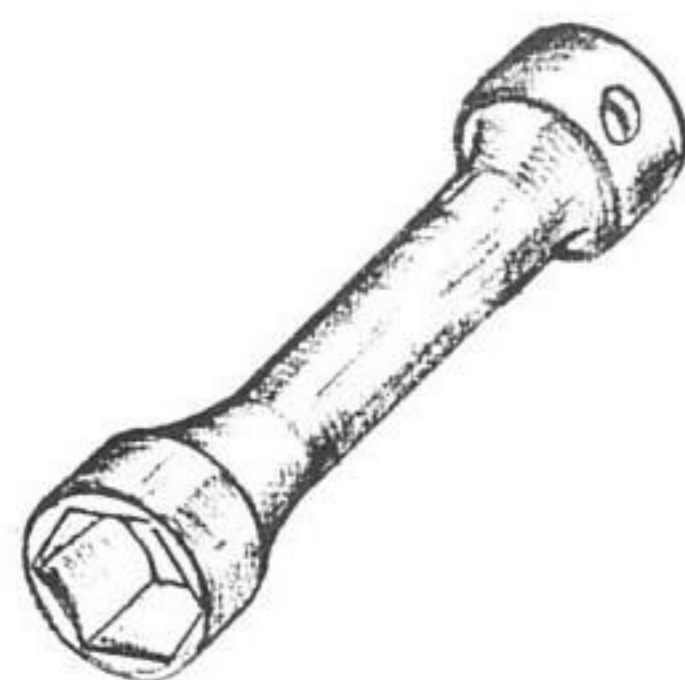

US 165

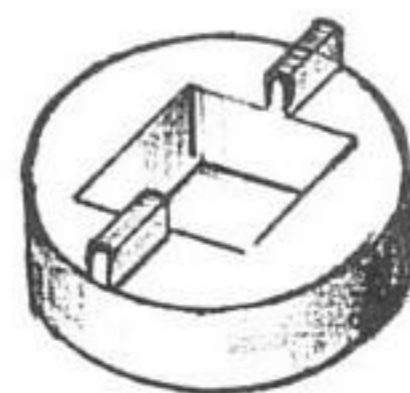

US 170

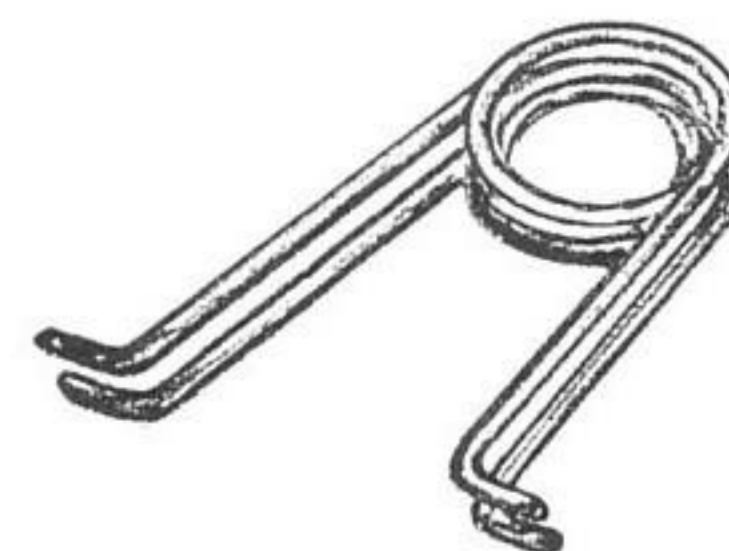

US 171



US 172

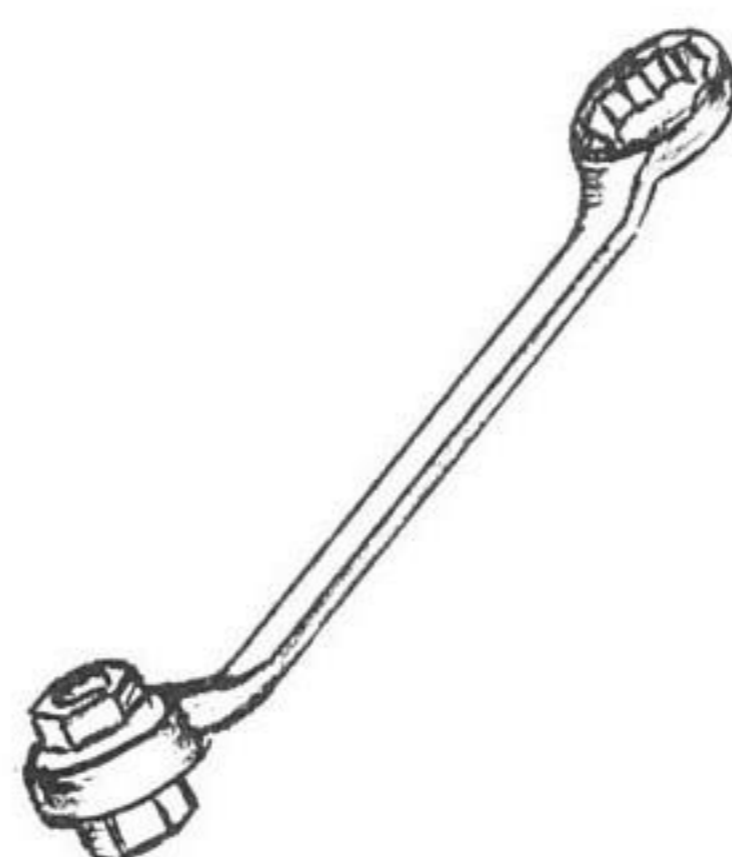

US 172 H



US 173



US 174

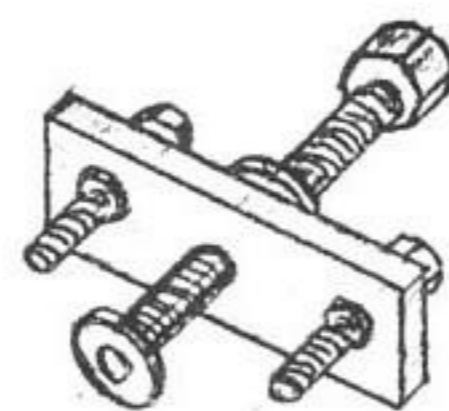

US 176



US 177

Special **TOOLS**

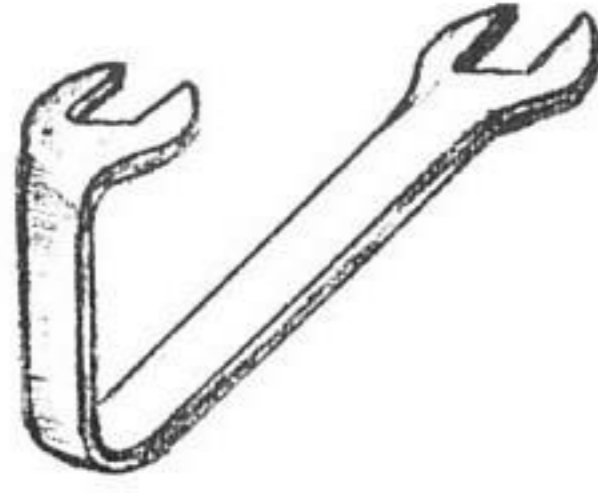

US 178



US 179

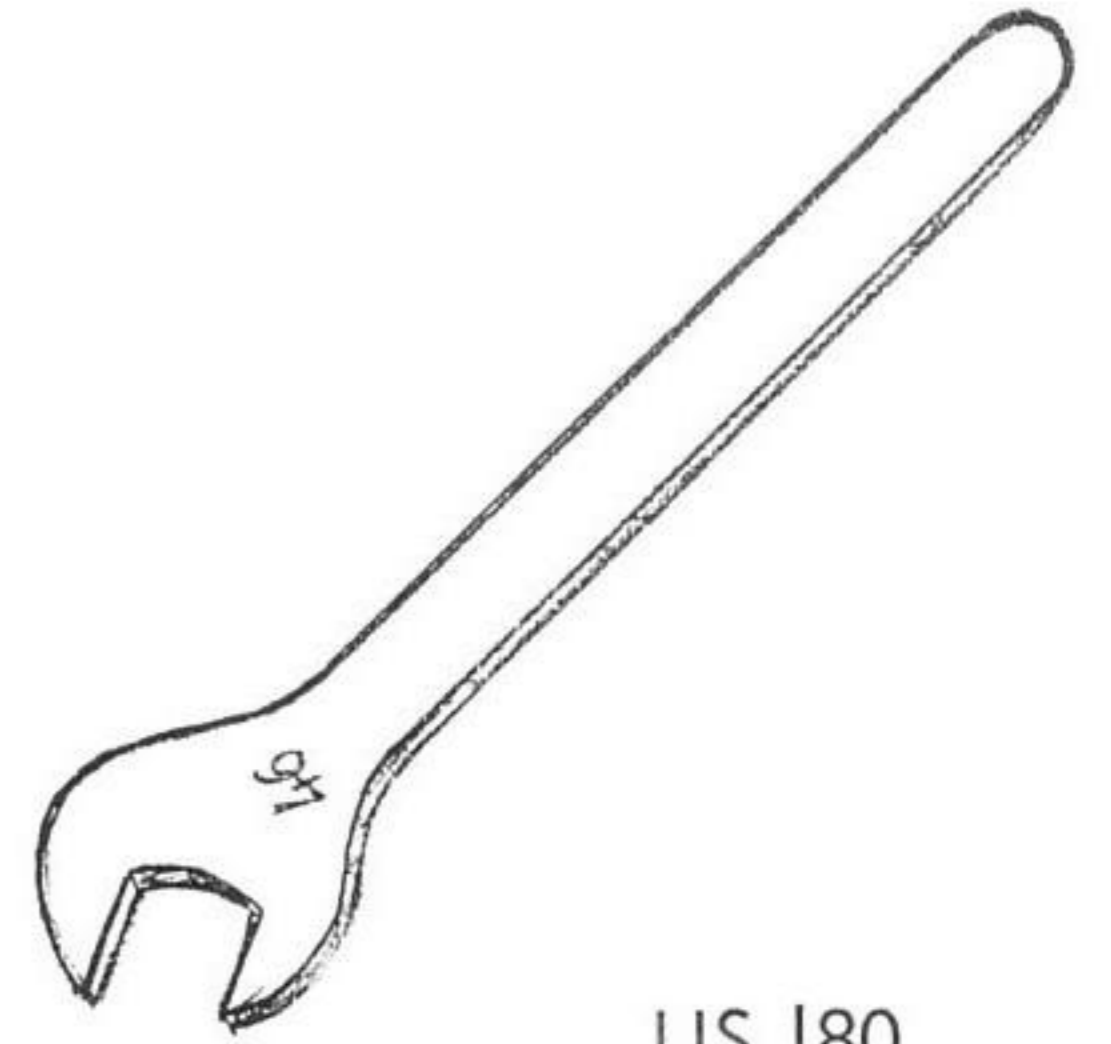

US 180



US 181

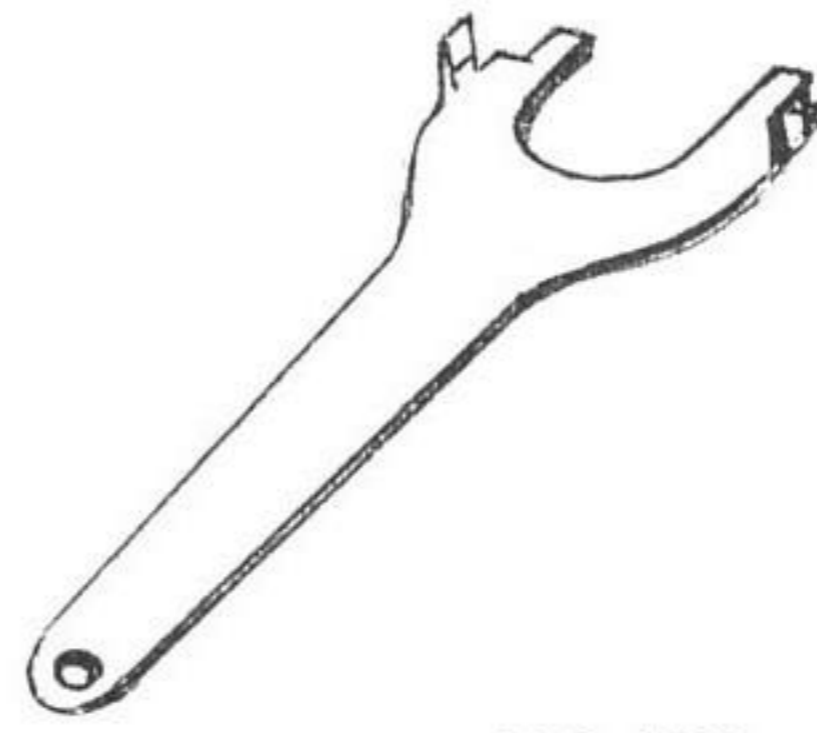

US 182

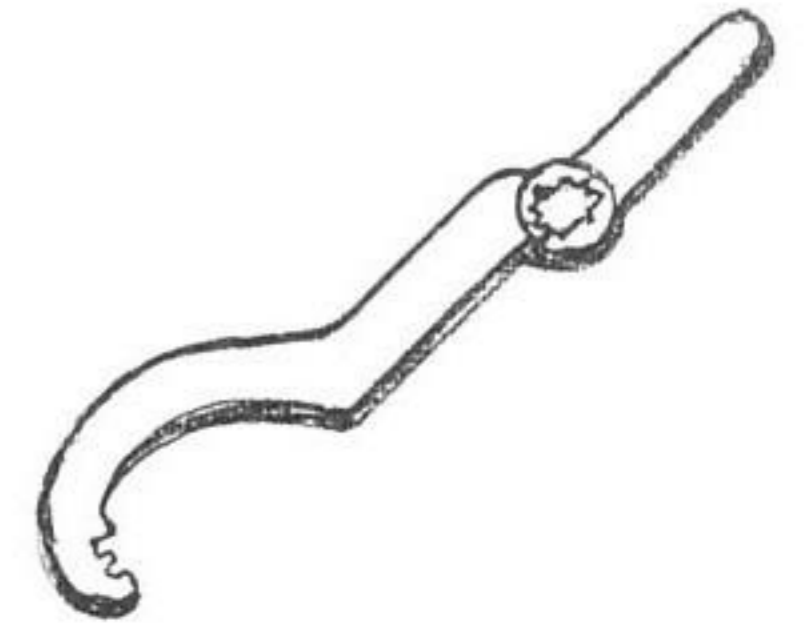

US 183

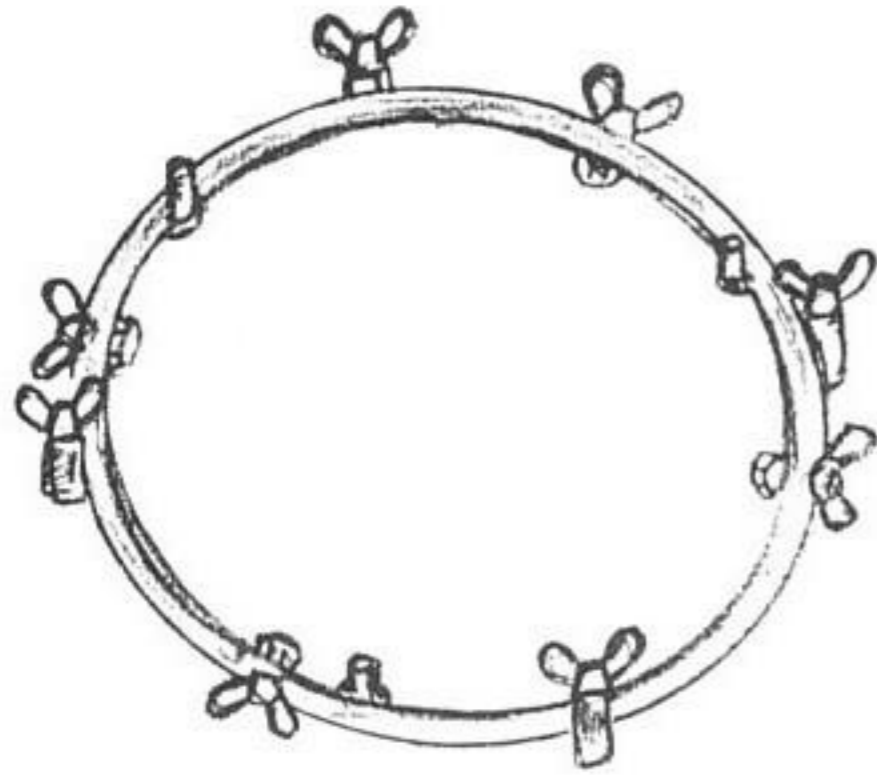

US 184

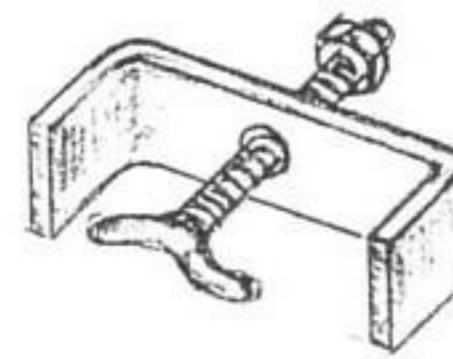

US 201

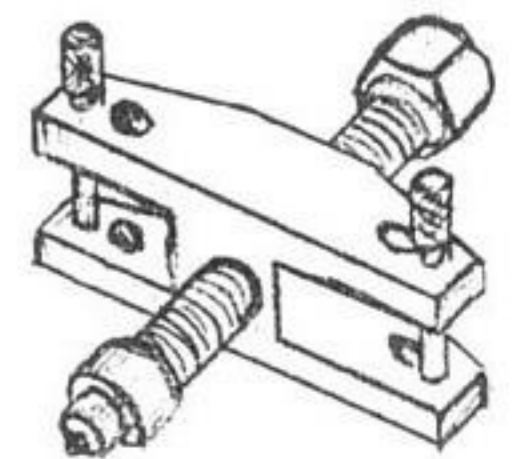

US 202

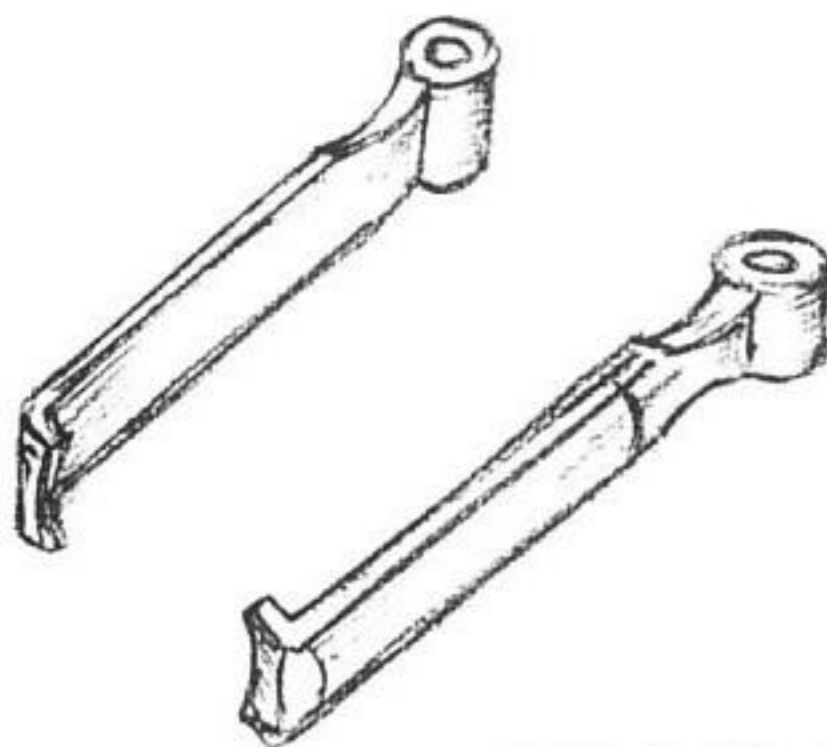

US 202 A

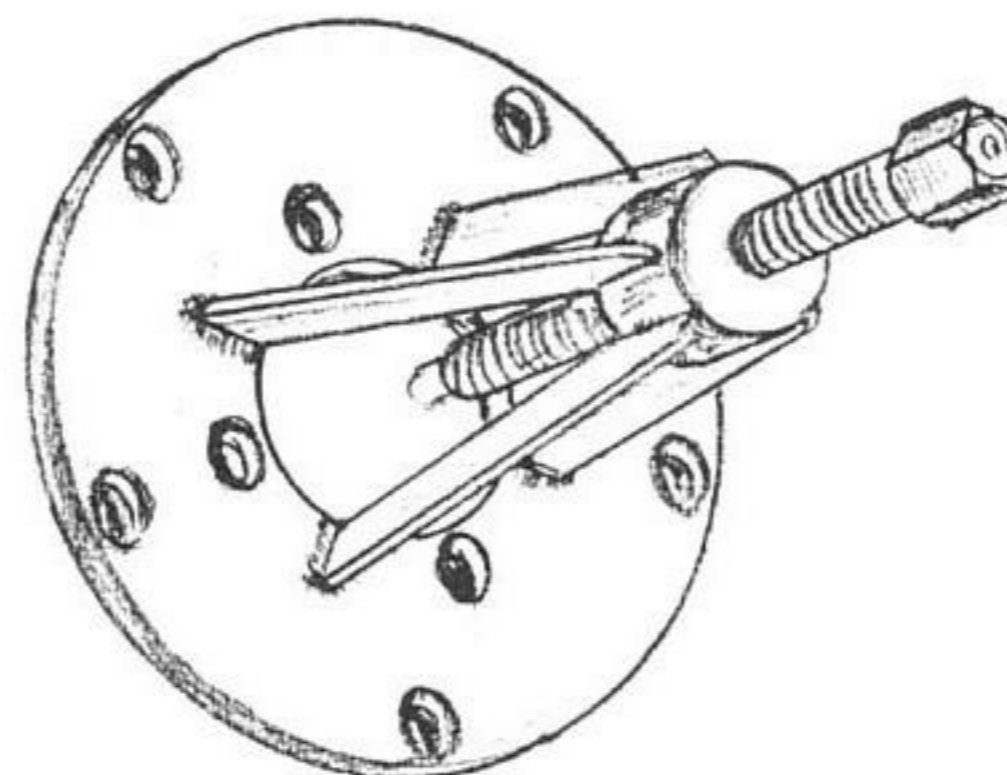

US 202 BZ

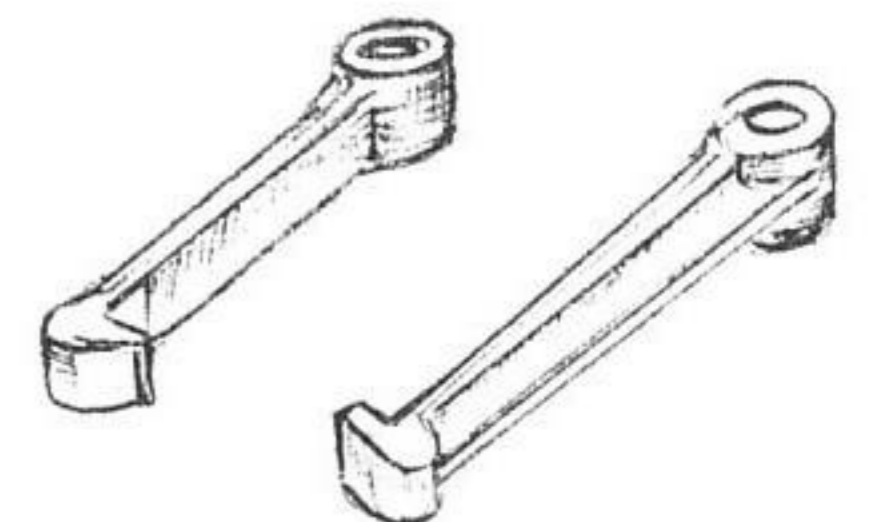

US 202 D

Special **TOOLS**

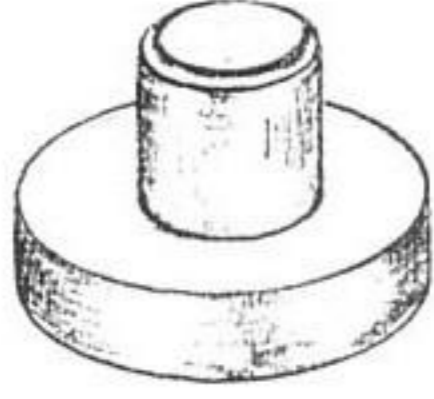

US 202 F

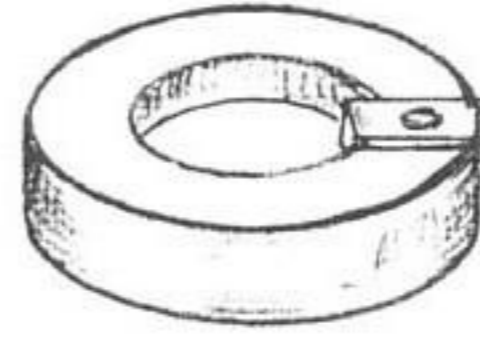

US 202 I

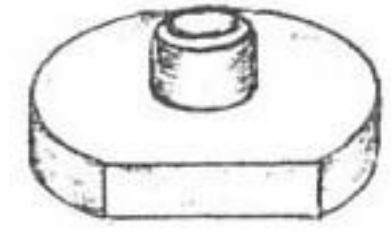

US 202 K

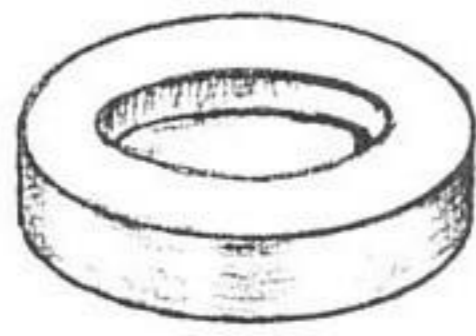

US 202 M

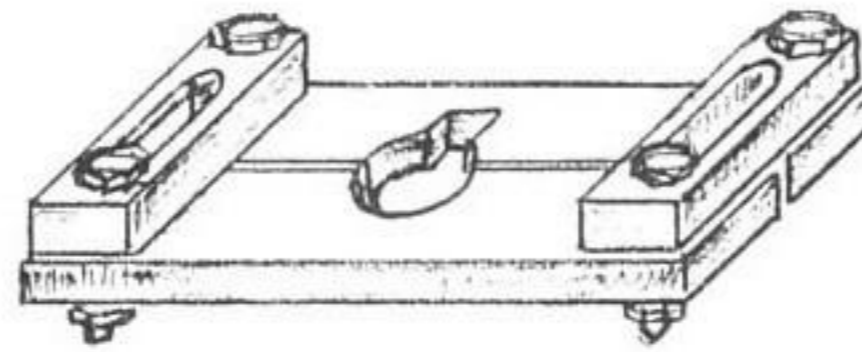

US 202 P

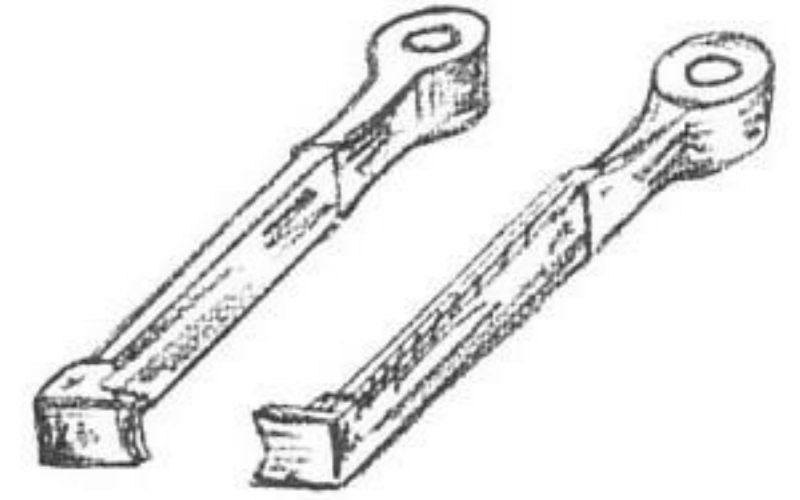

US 202 S

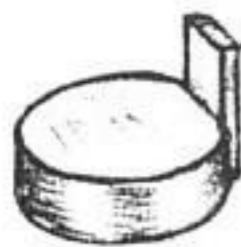

US 202 T

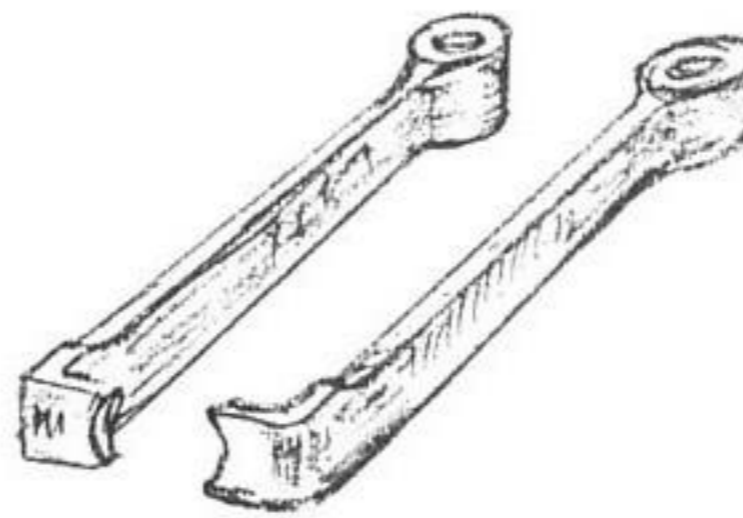

US 202 U

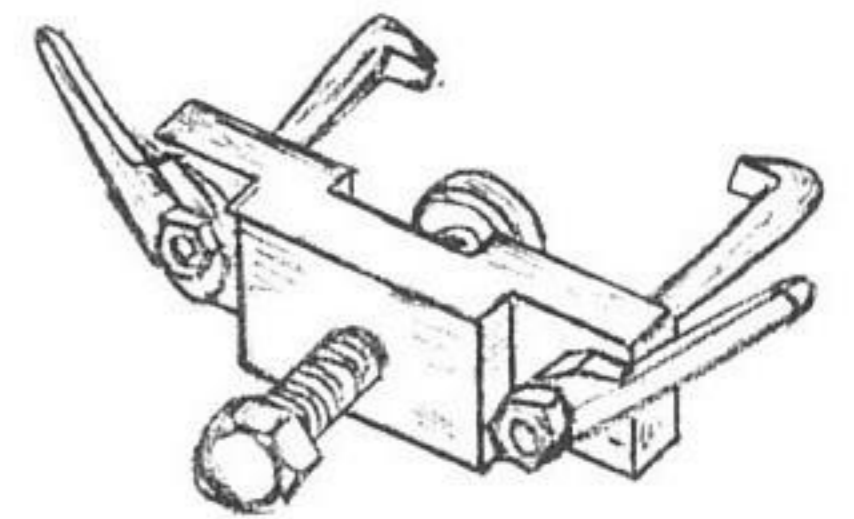

US 203 B

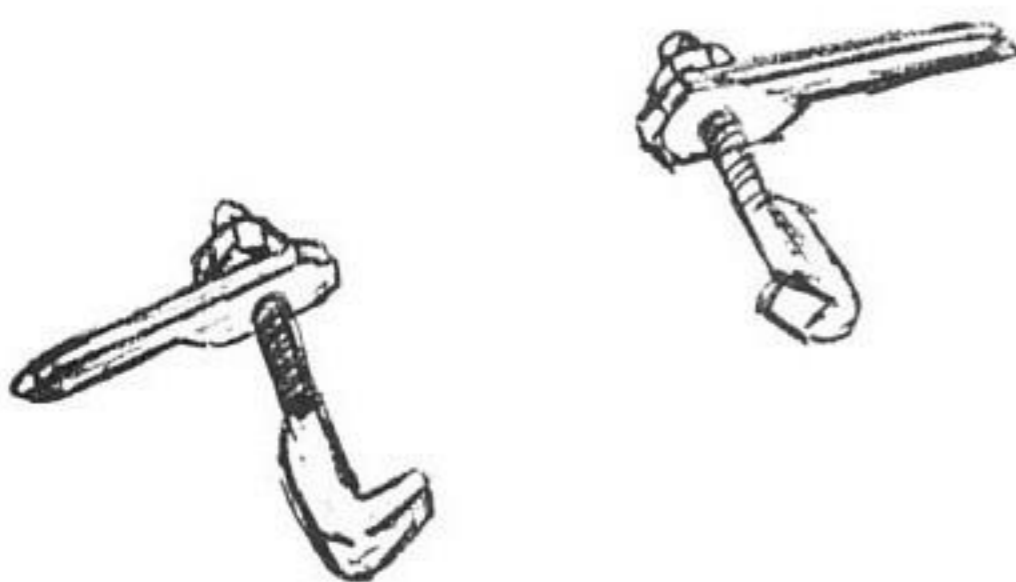

US 203 B-6

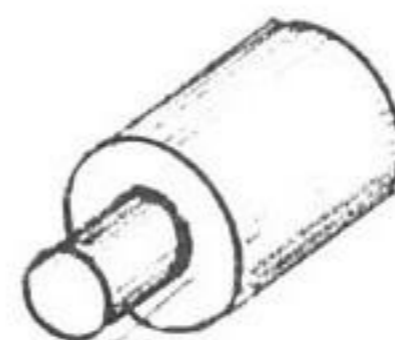

US 203 D

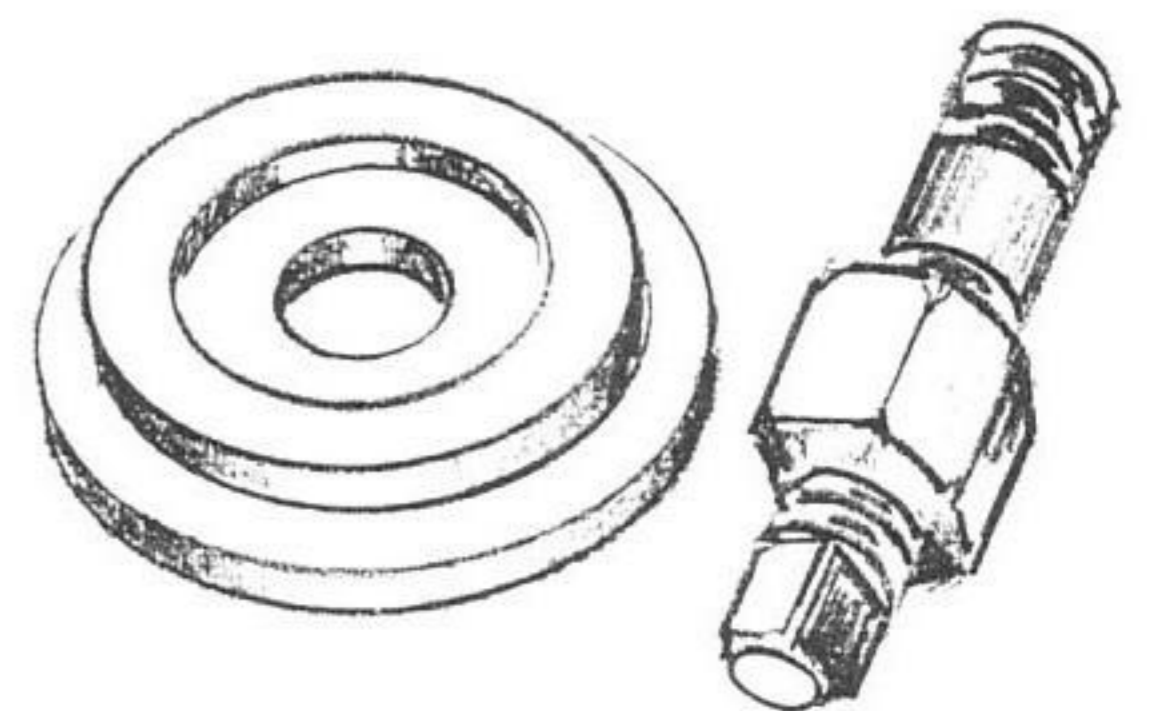

US 204 B



Special TOOLS



US 207



US 207-1

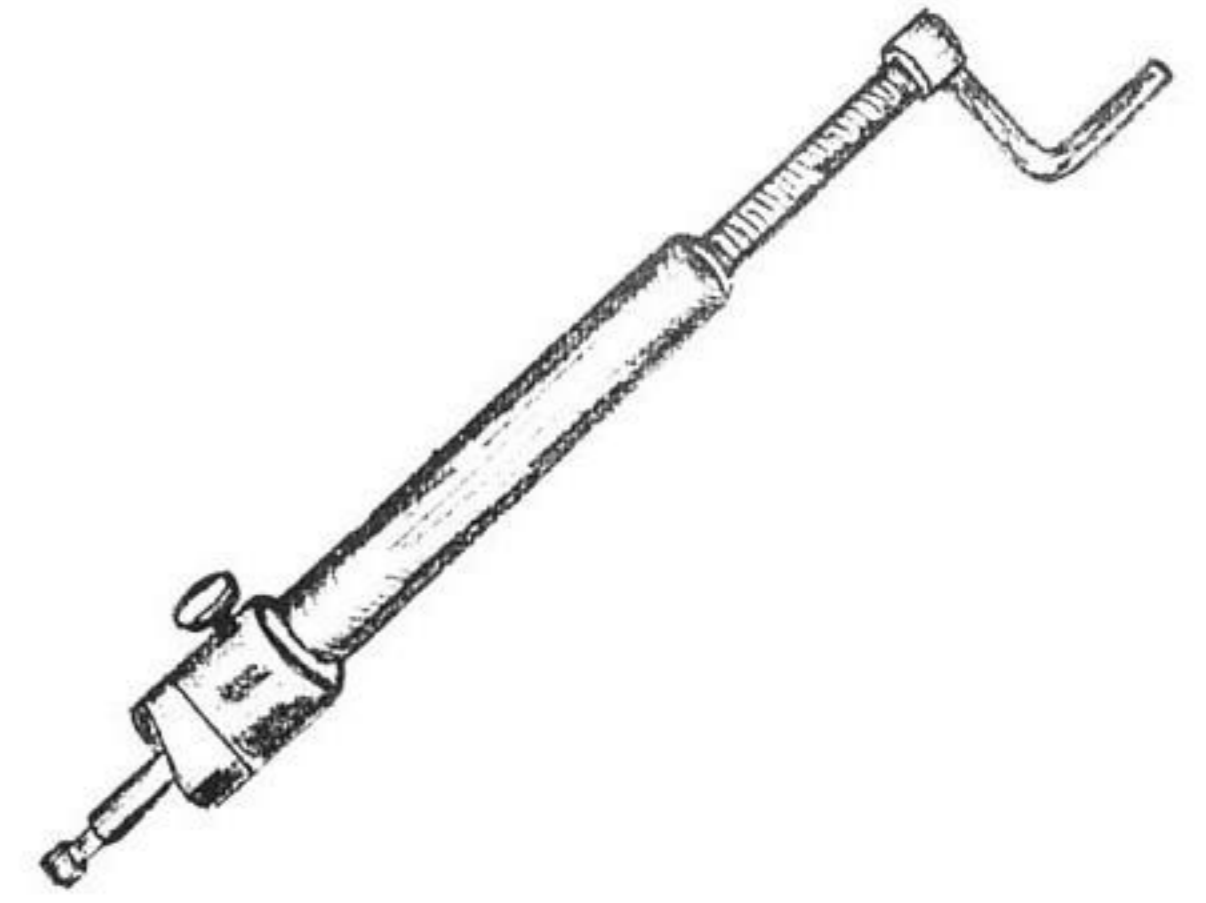

US 207 B



US 212 A

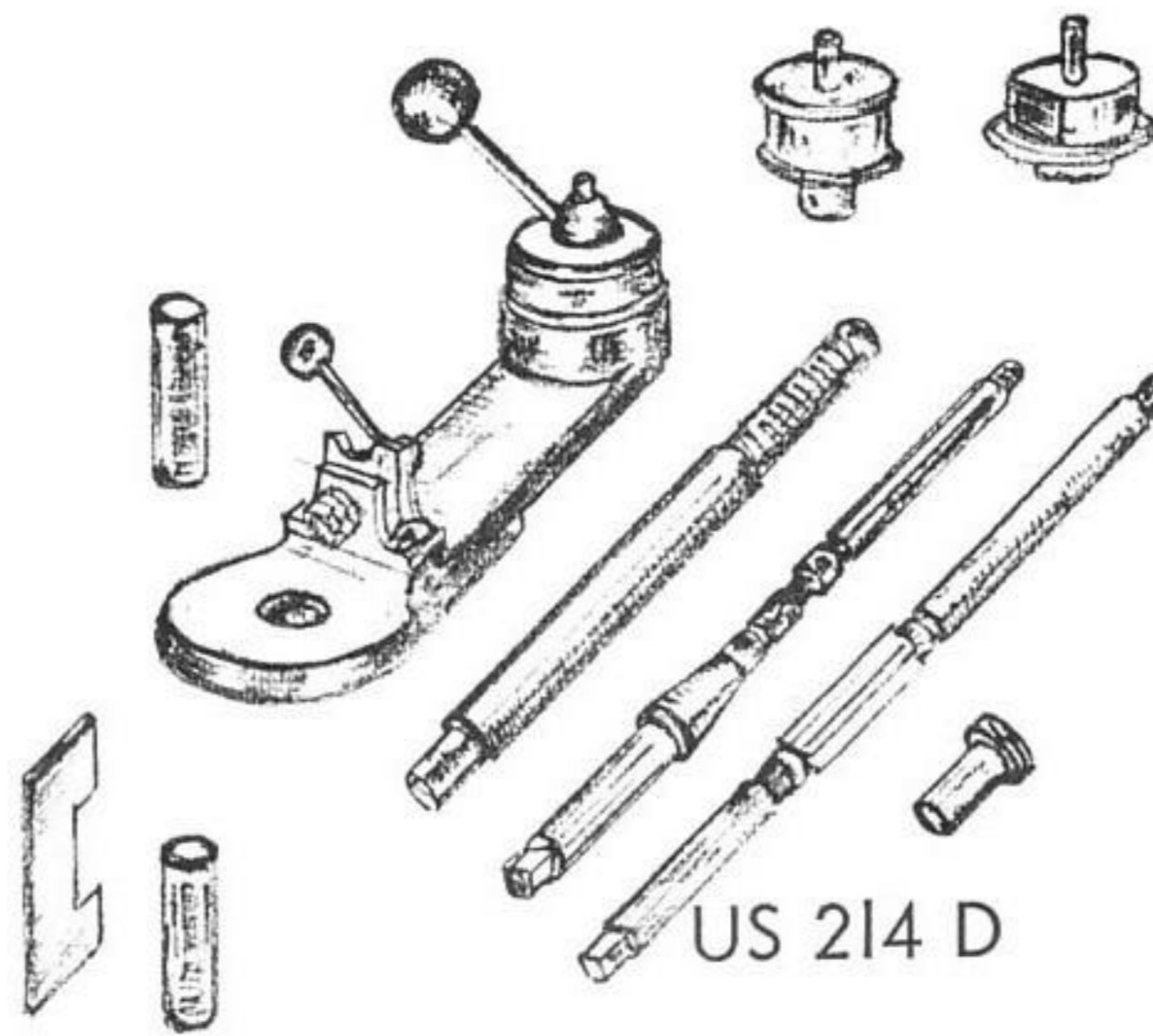

US 214 D

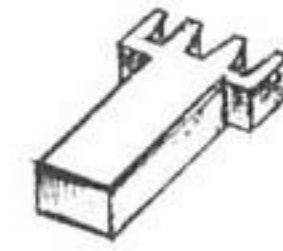

US 215



US 215 B



US 215 C

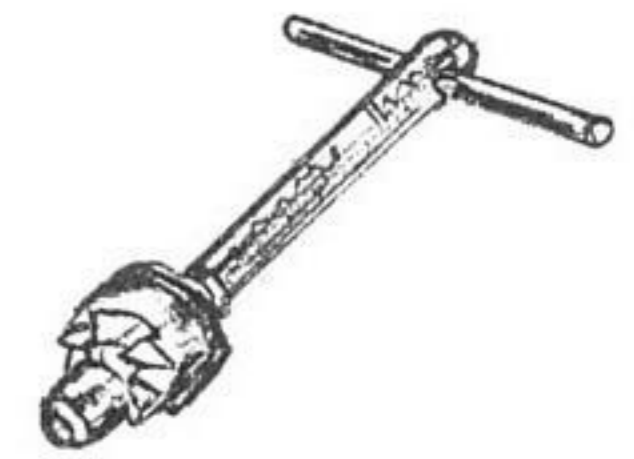

US 217

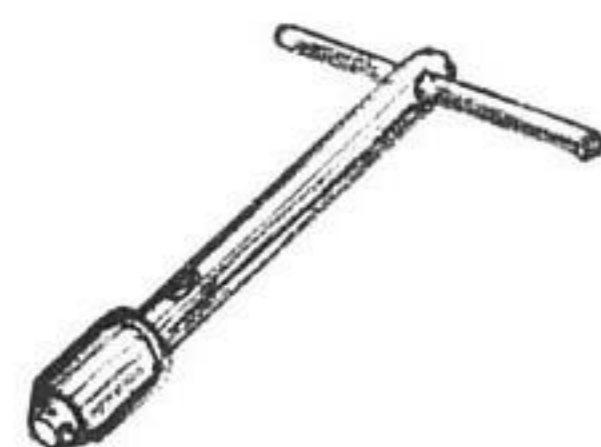

US 217 A

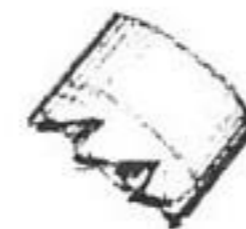

US 217 Z



US 219

Special TOOLS



US 219 A



US 222 A



US 224

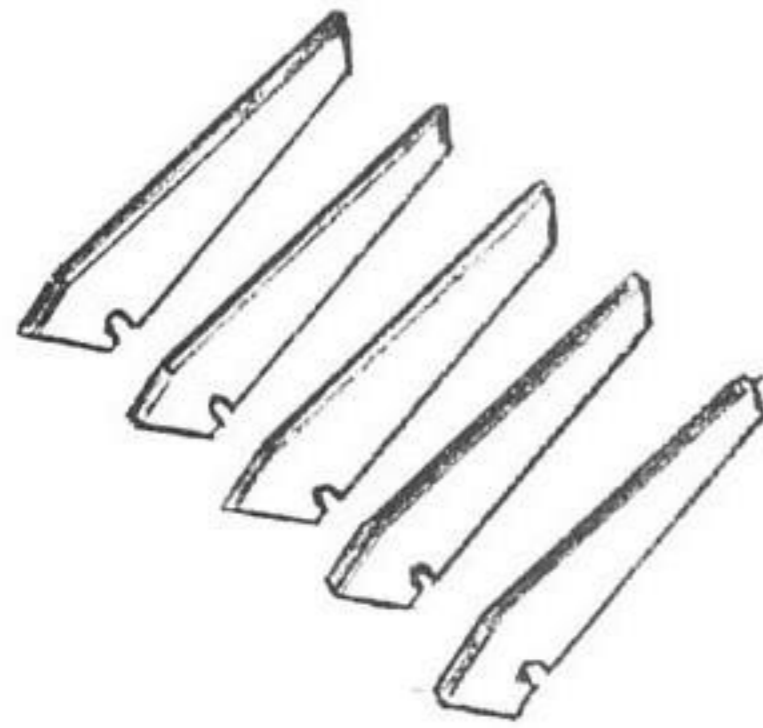

US 224-1

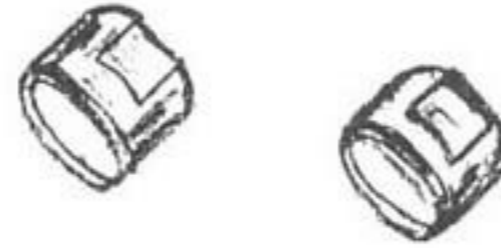

US 224-2



US 224 A



US 224 A-1

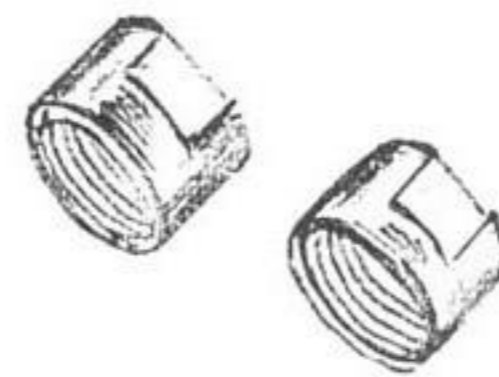

US 224 A-2

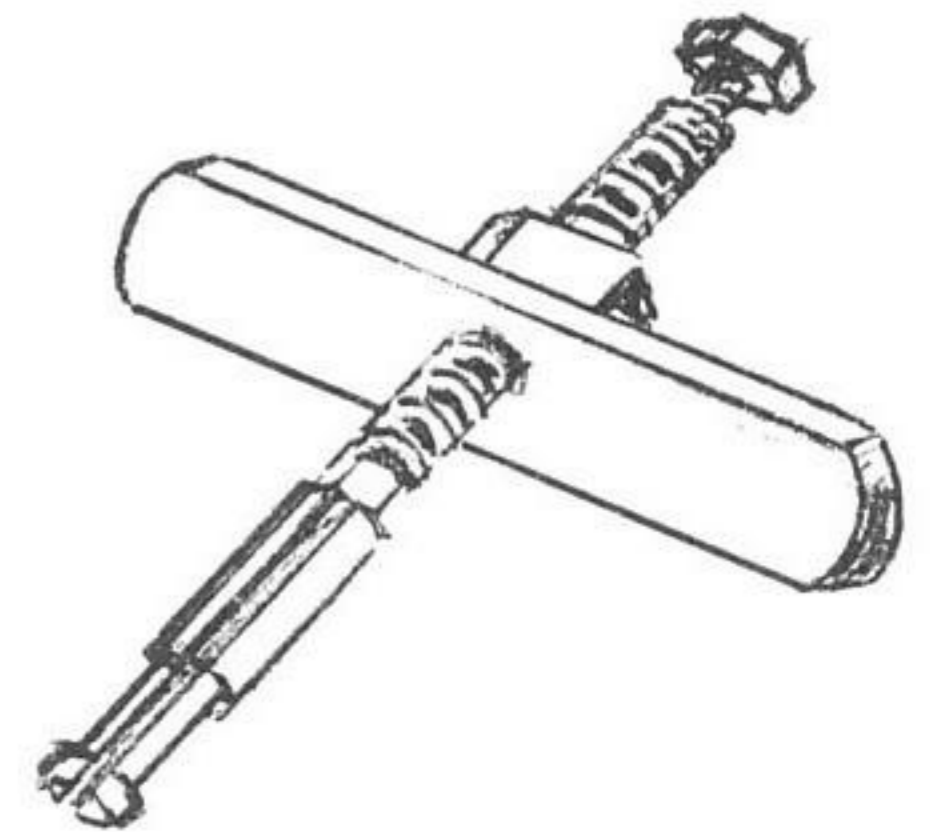

US 228 A

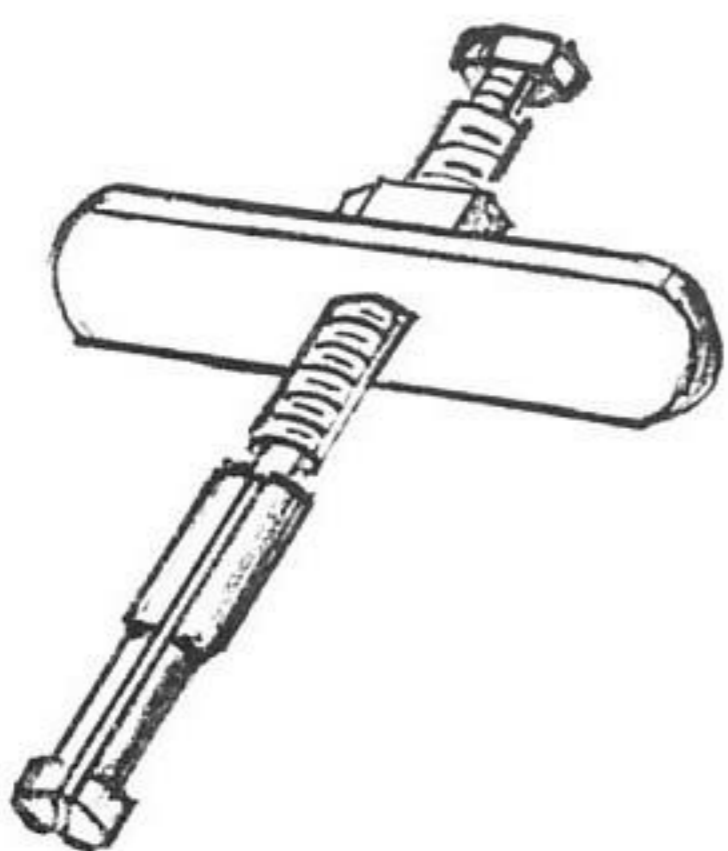

US 228 B

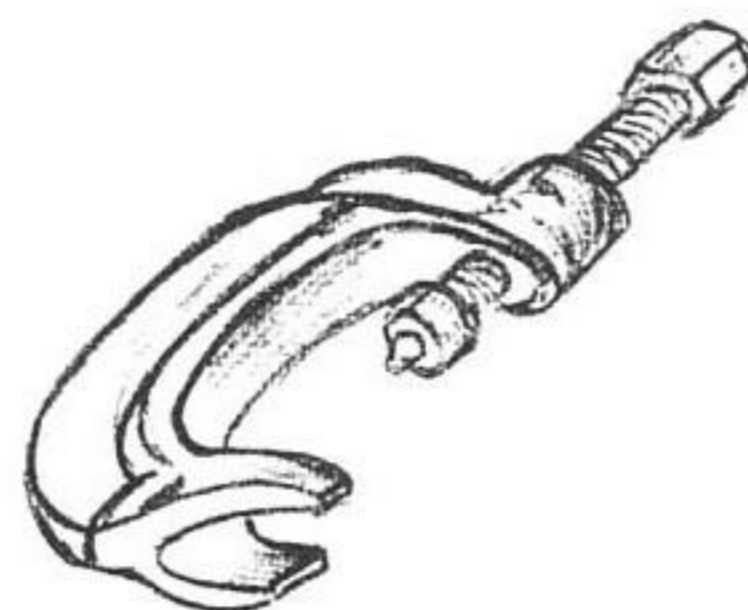

US 235

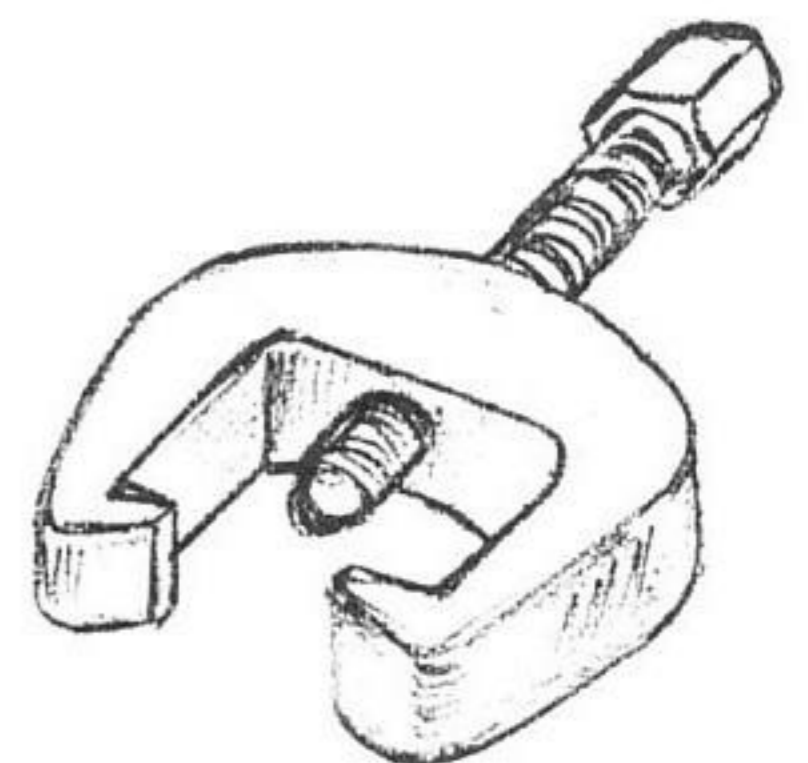

US 236

Special TOOLS

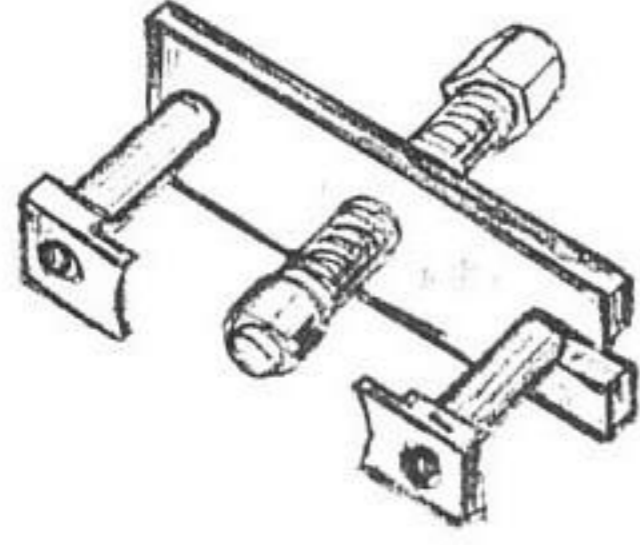

US 237



US 240 A



US 241 A



US 241 A-4



US 243



US 244

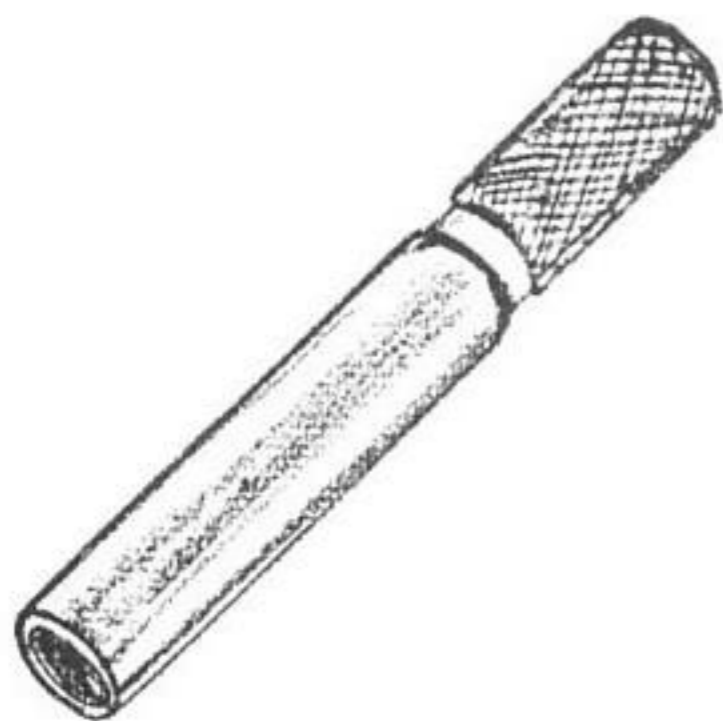

US 244 B



US 244 C



US 244 D

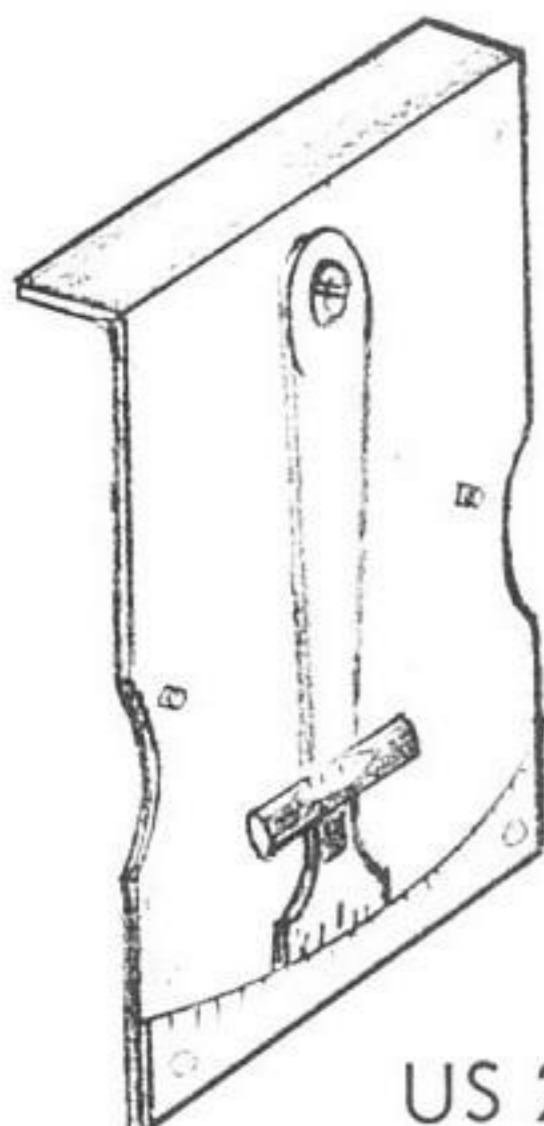

US 245 A



US 245 A-1



US 246

Special TOOLS



US 248



US 249

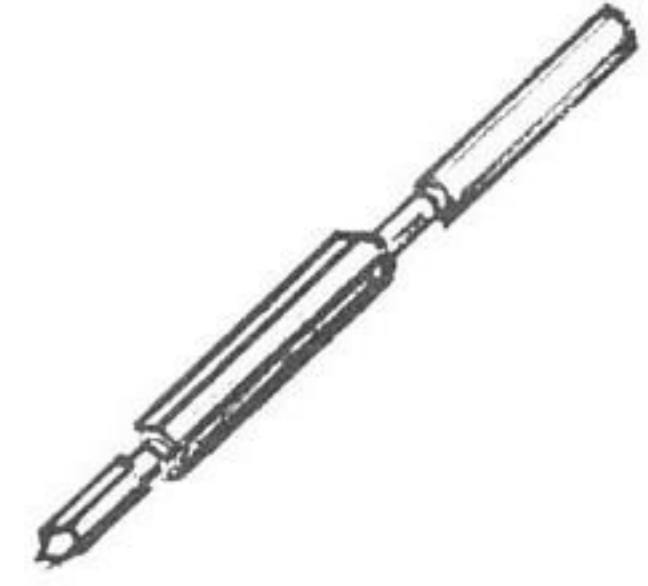

US 253



US 253 A

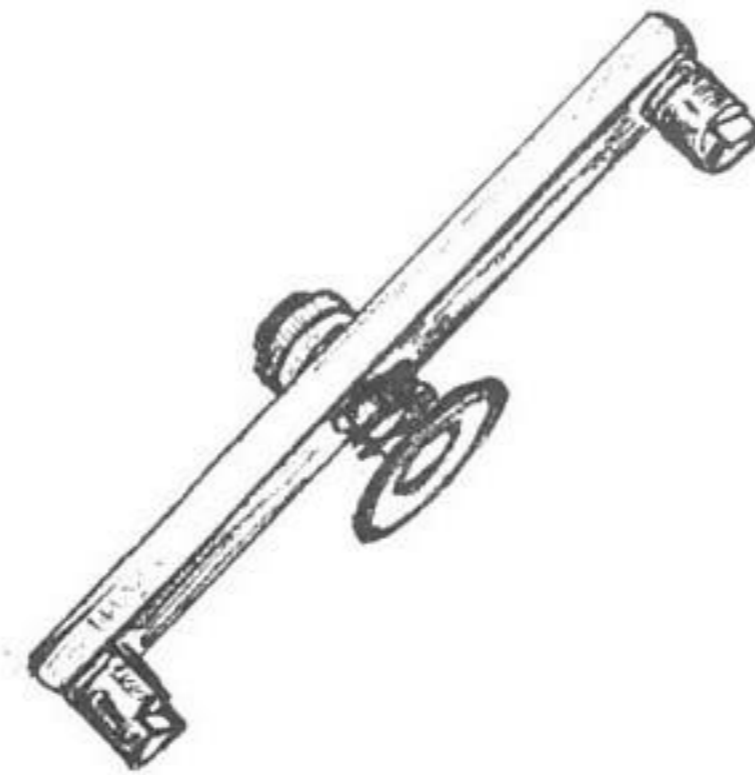

US 254 A

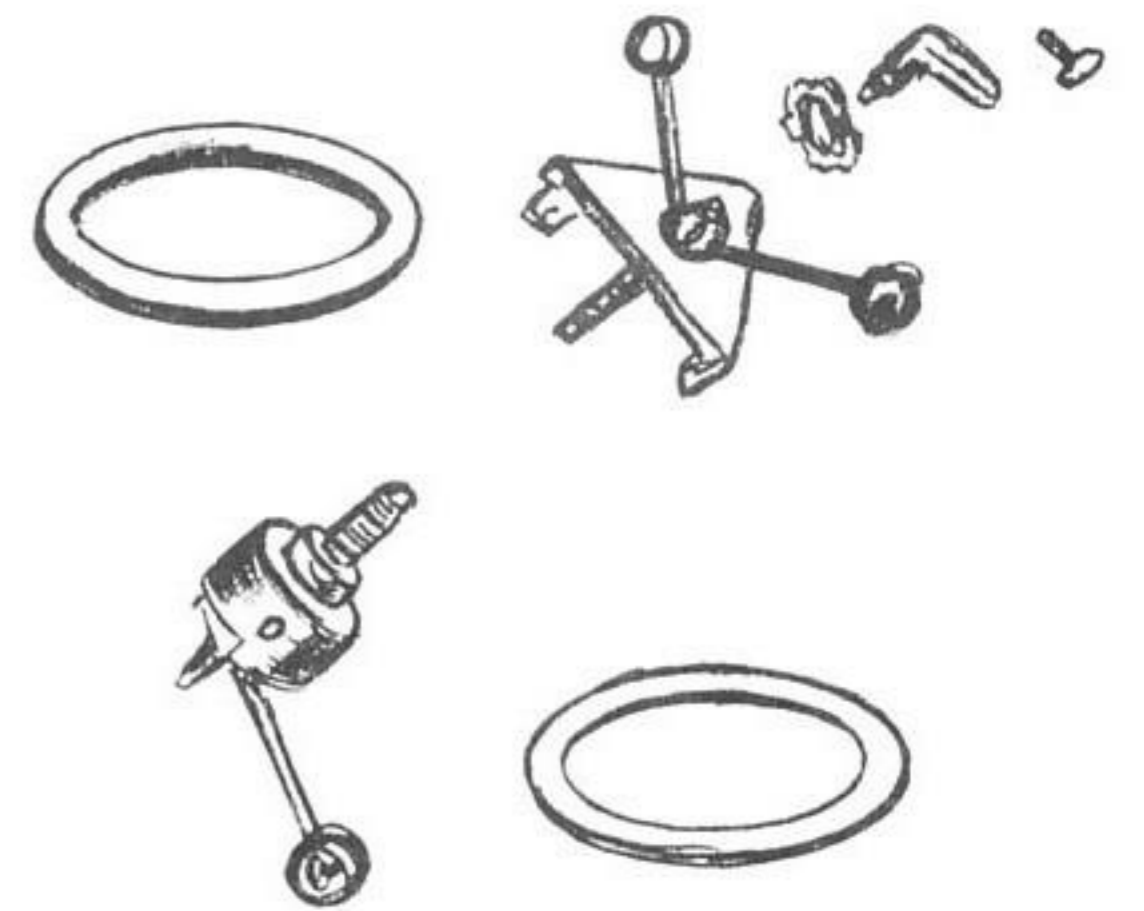

US 254 B

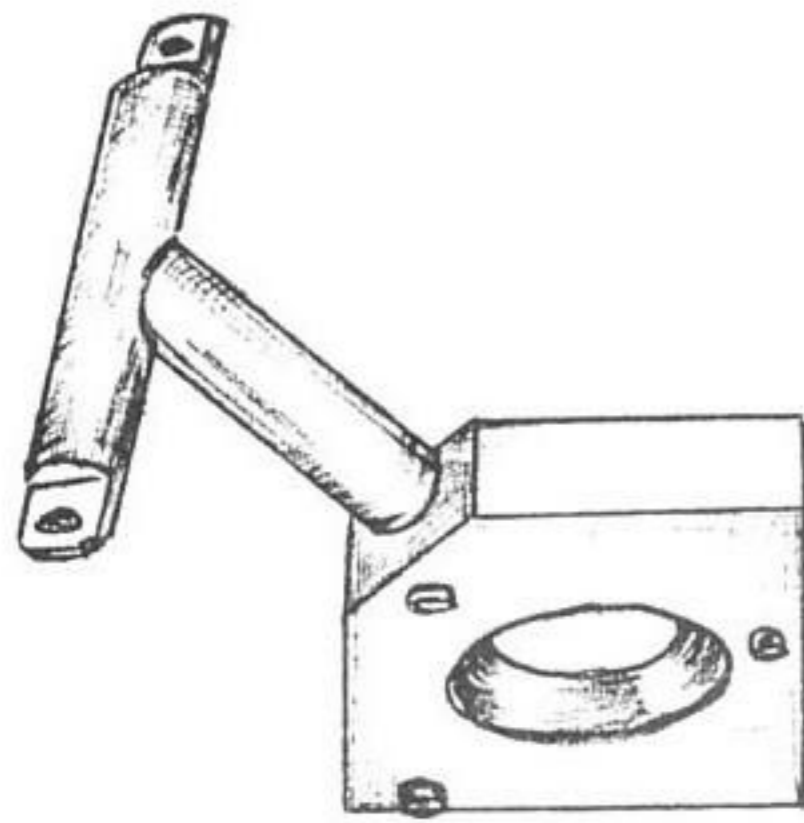

US 258 A



US 258 D

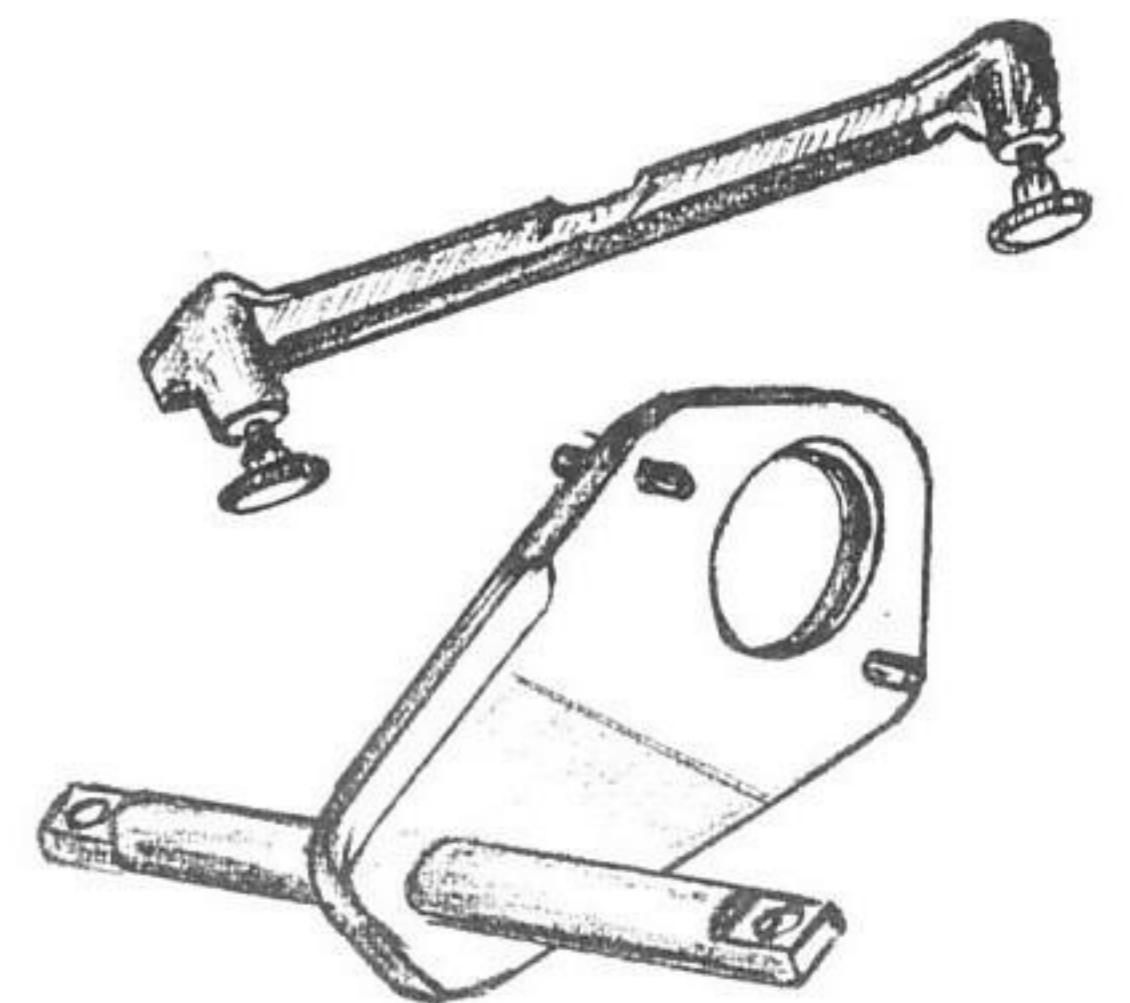

US 258 F

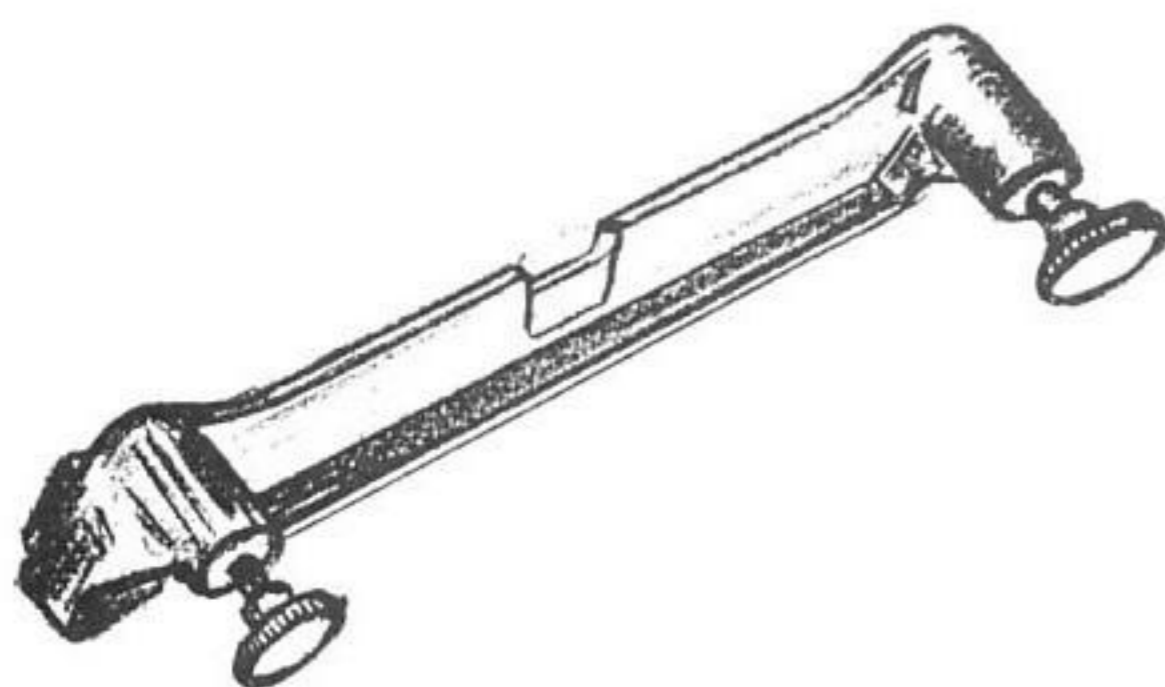

US 258 F/2

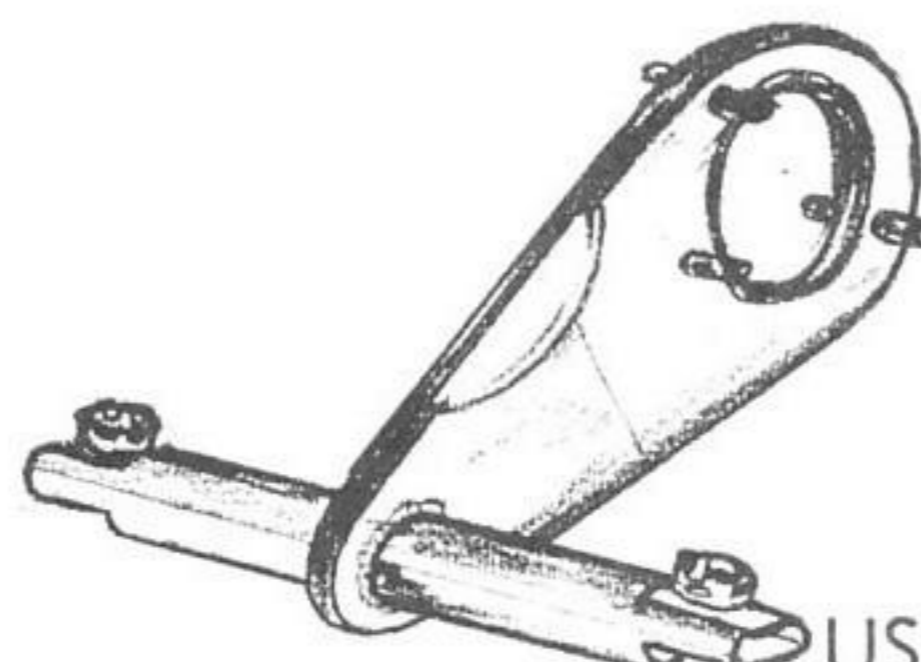

US 258 H

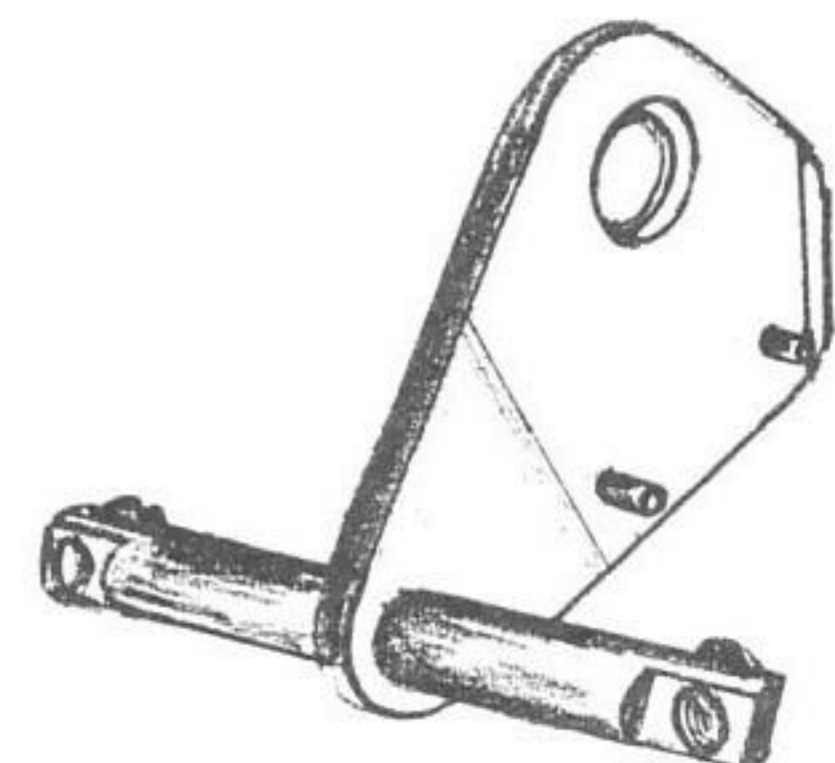

US 258 M

Special TOOLS

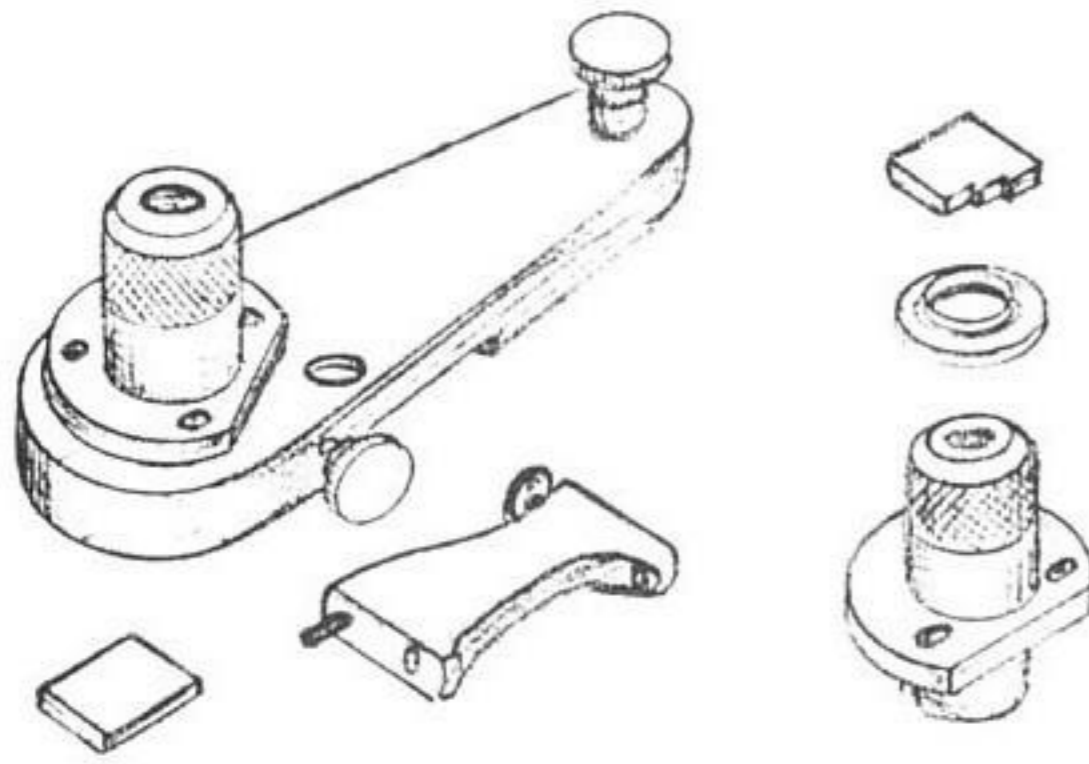

US 258 P

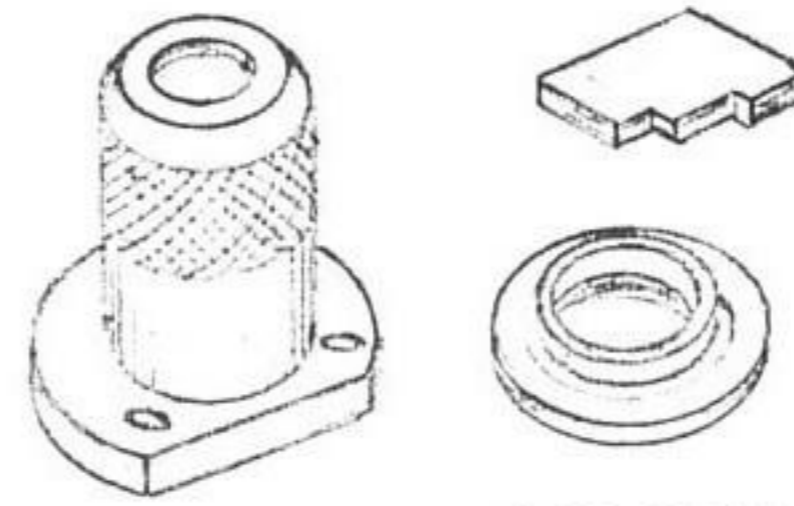

US 258 K/50

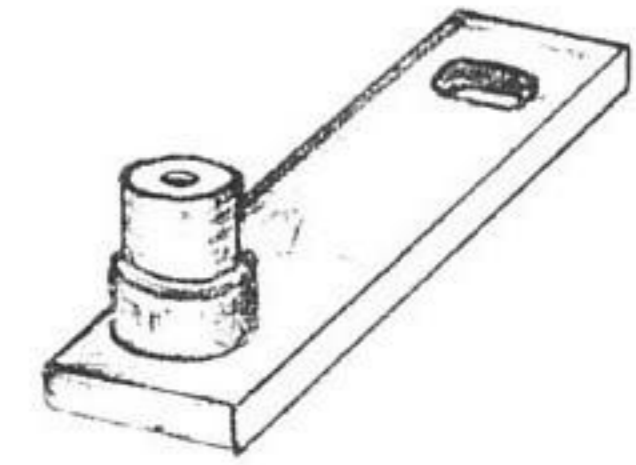

US 259

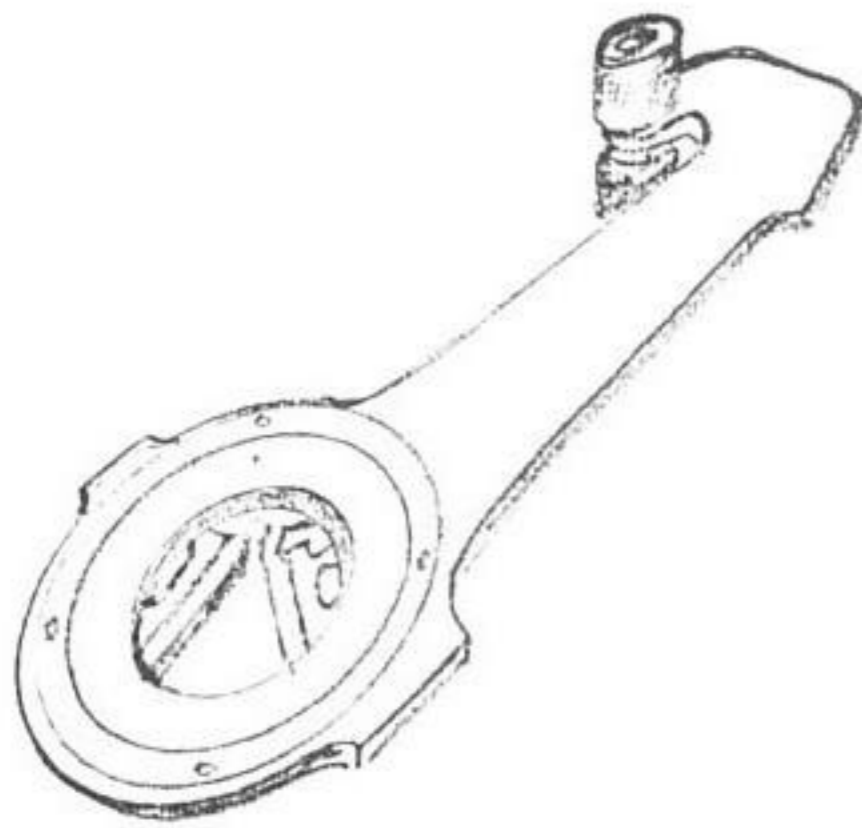

US 261

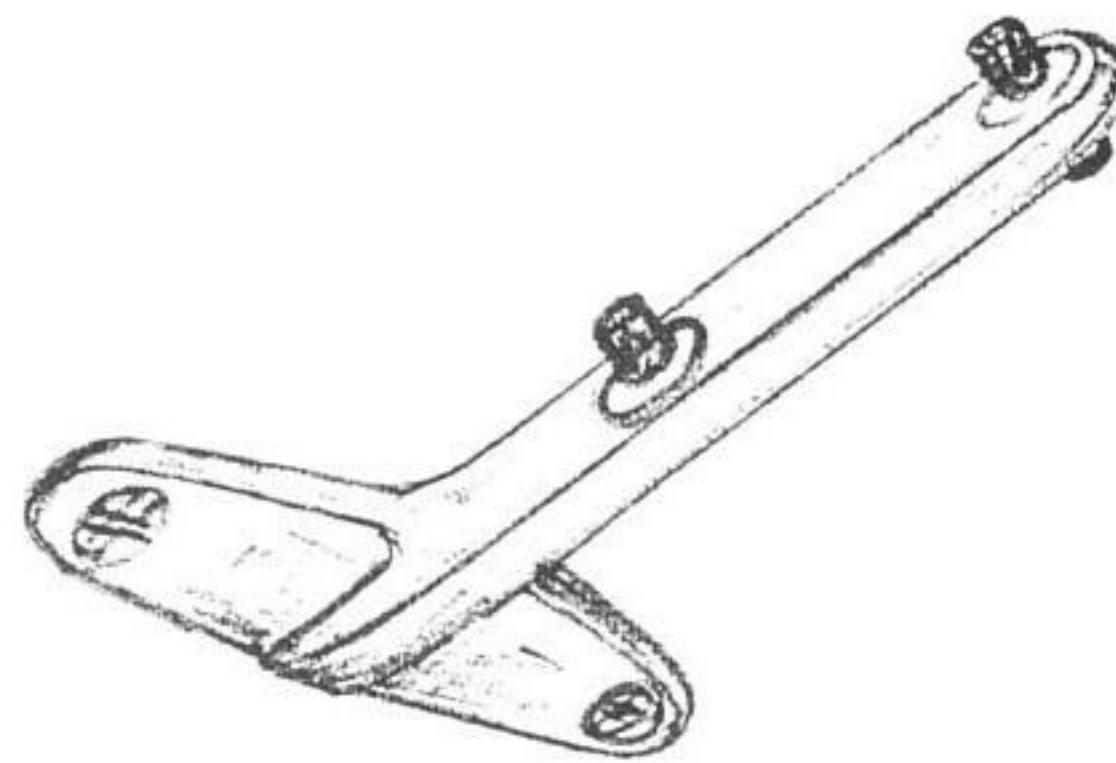

US 262



US 266 H

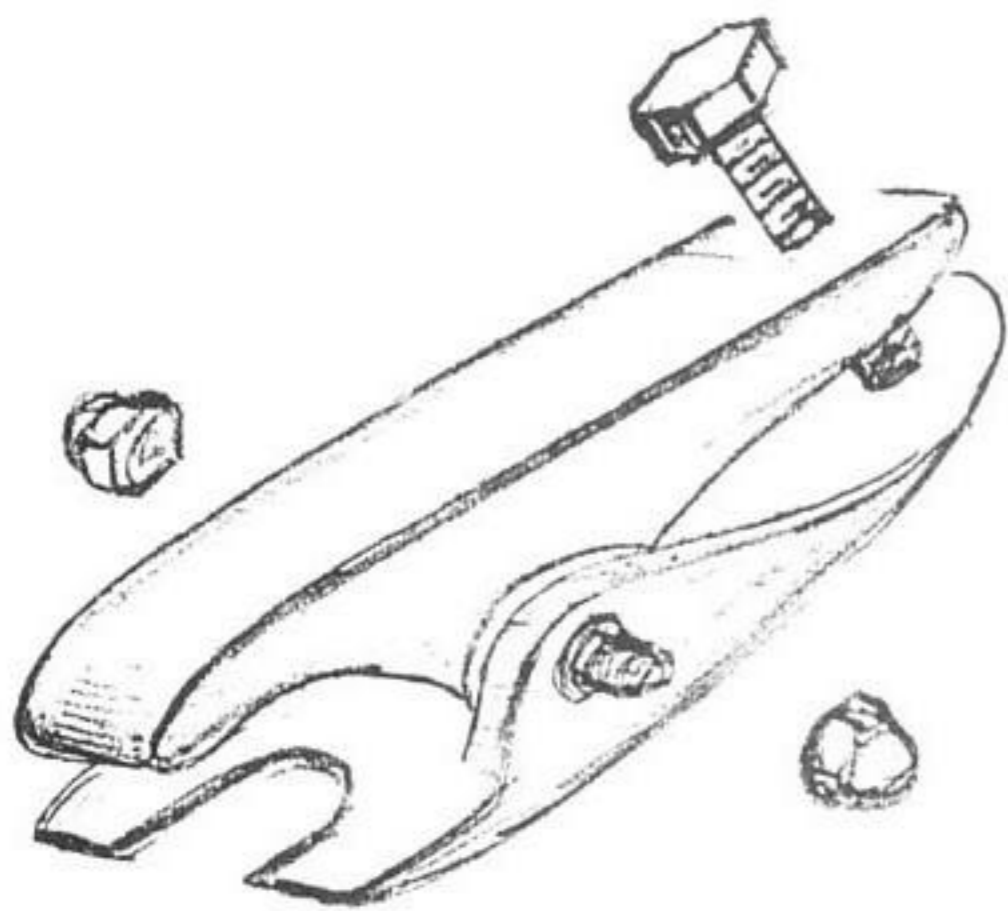

US 267 A

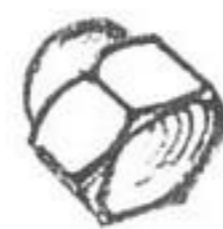

US 267/4

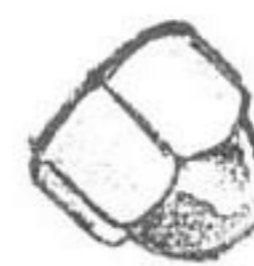

US 267/5

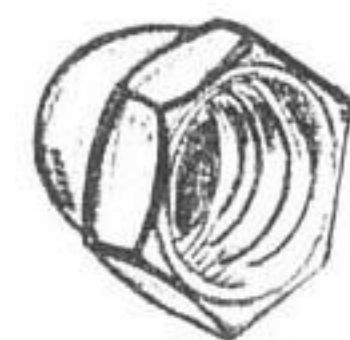

US 267/7

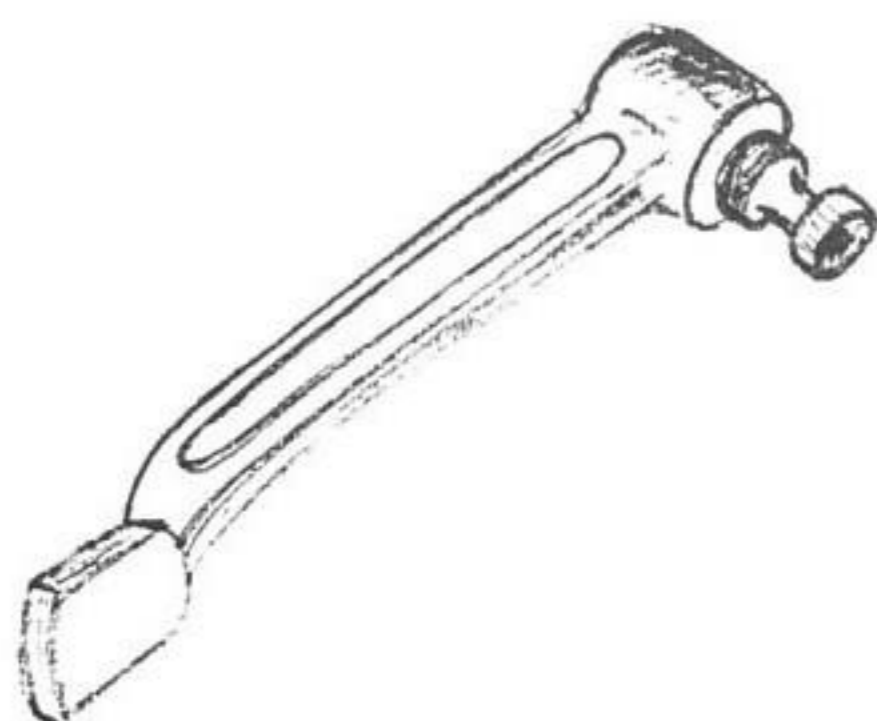

US 270 A

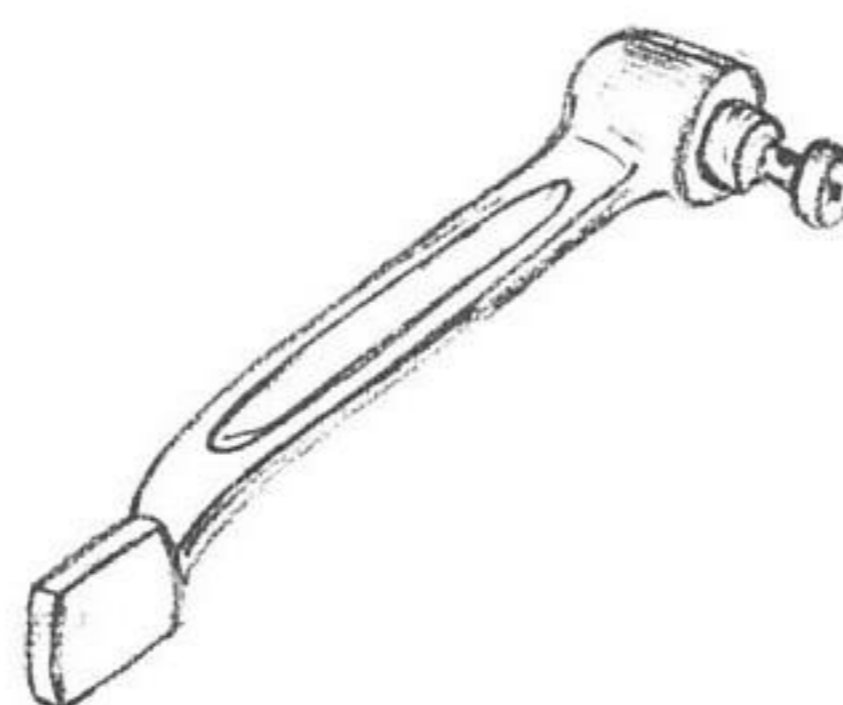

US 270 B

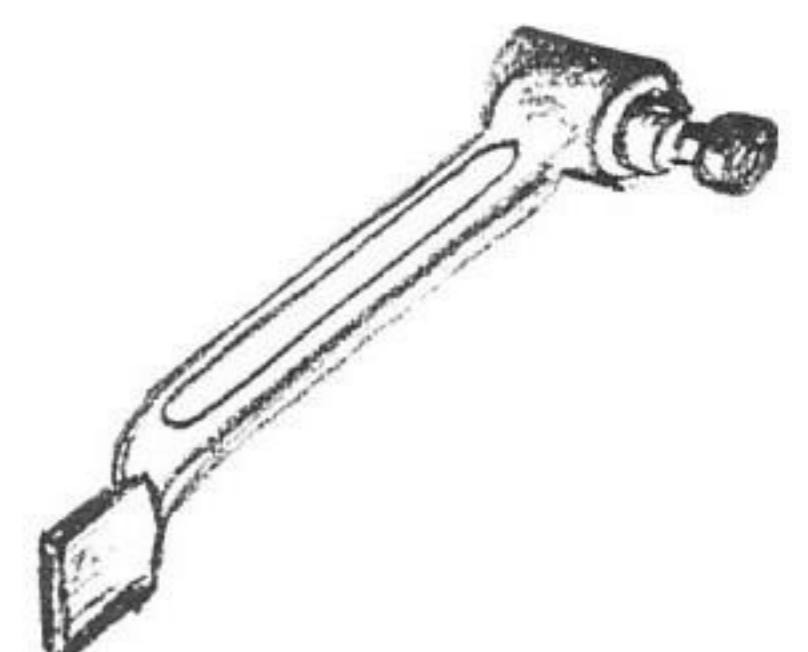

US 270 C

Special TOOLS



US 273 A



US 273 B



US 273 C



US 273 D



US 274 A

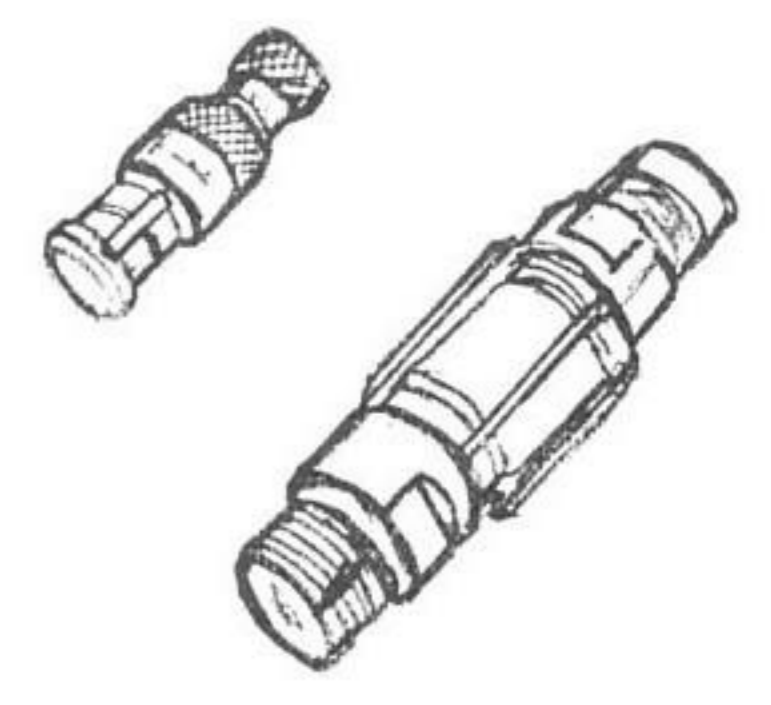

US 274A-R 20



US 274 B

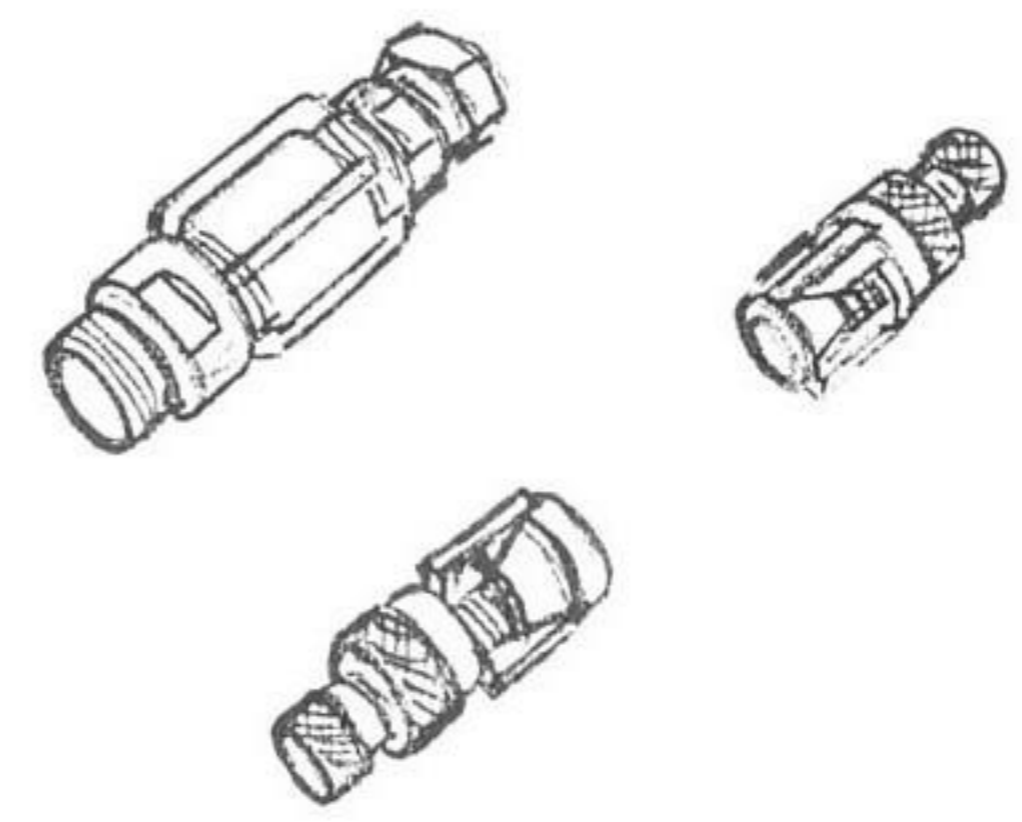

US 274B-R 20

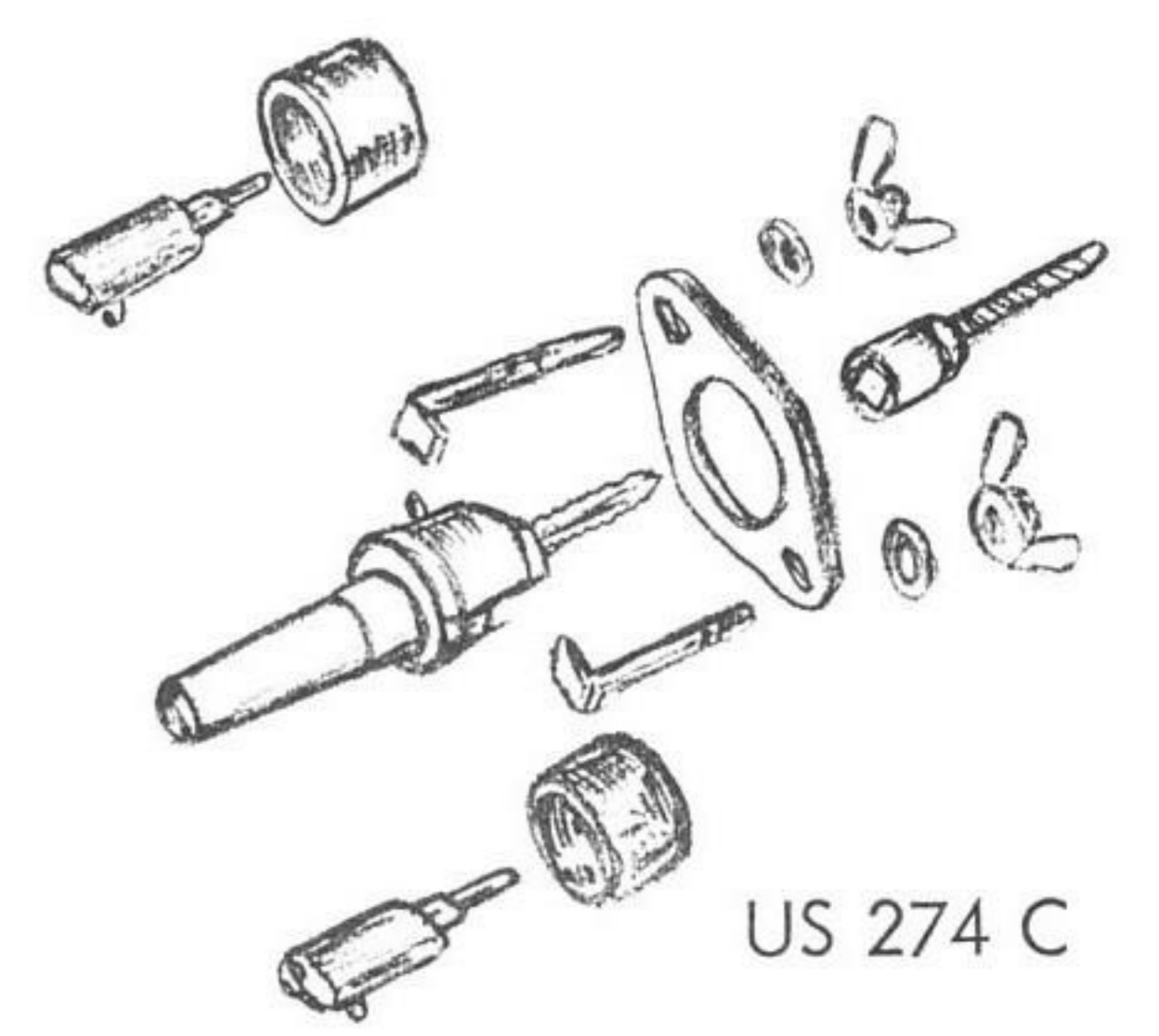

US 274 C

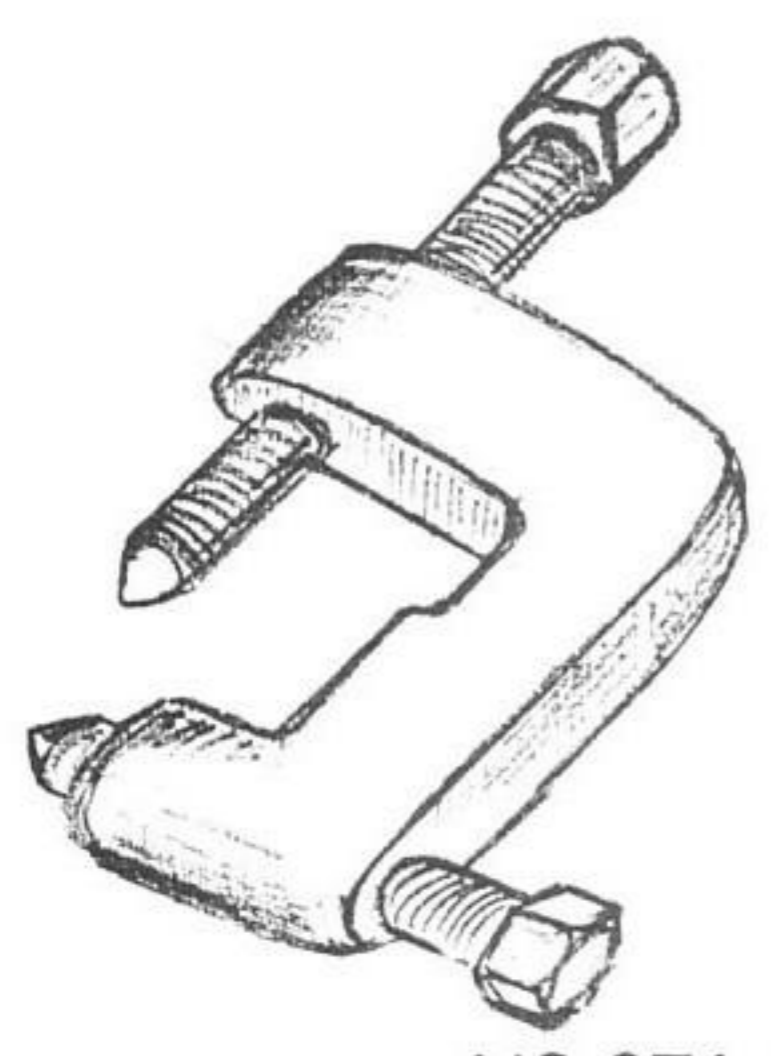

US 276 A



US 277

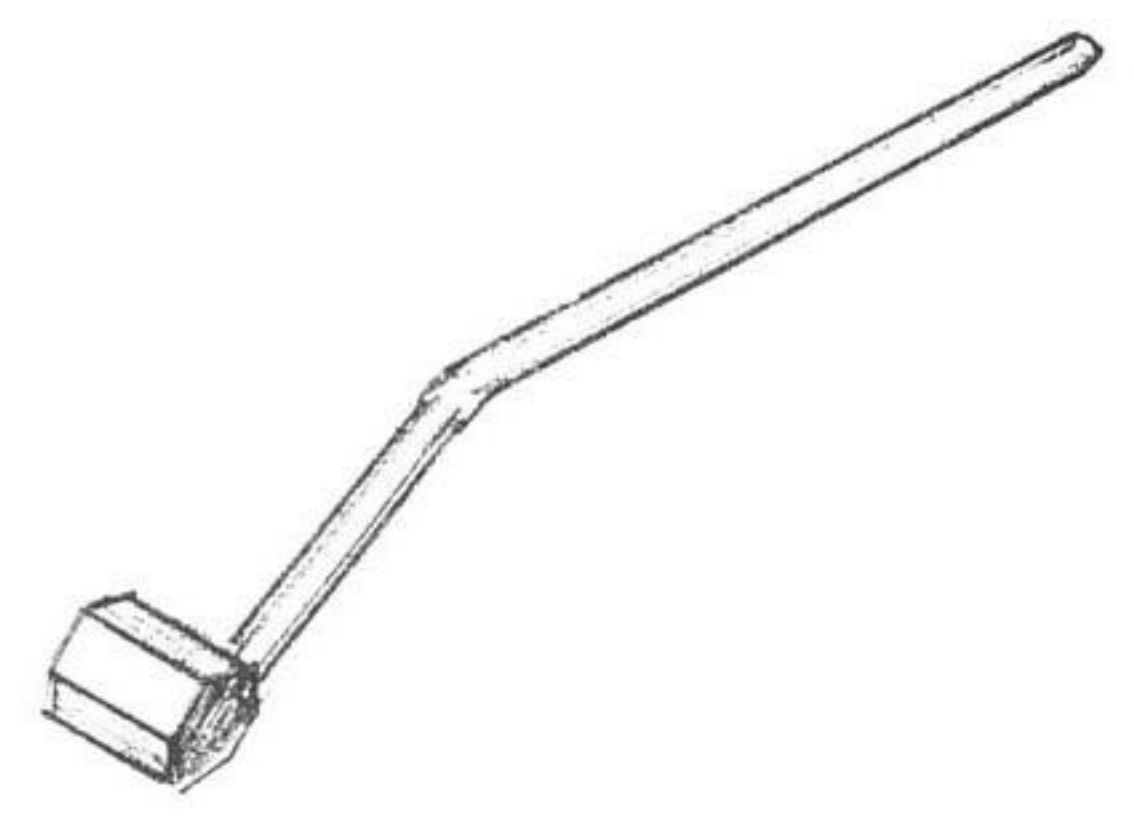

US 278 A

Special TOOLS

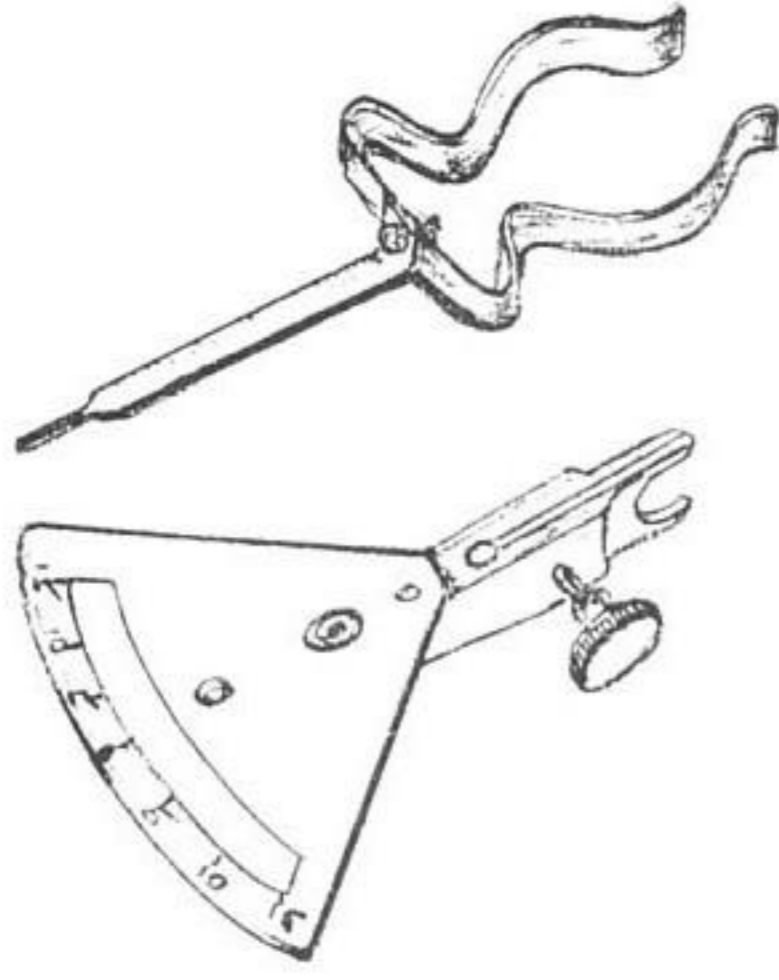

US 279

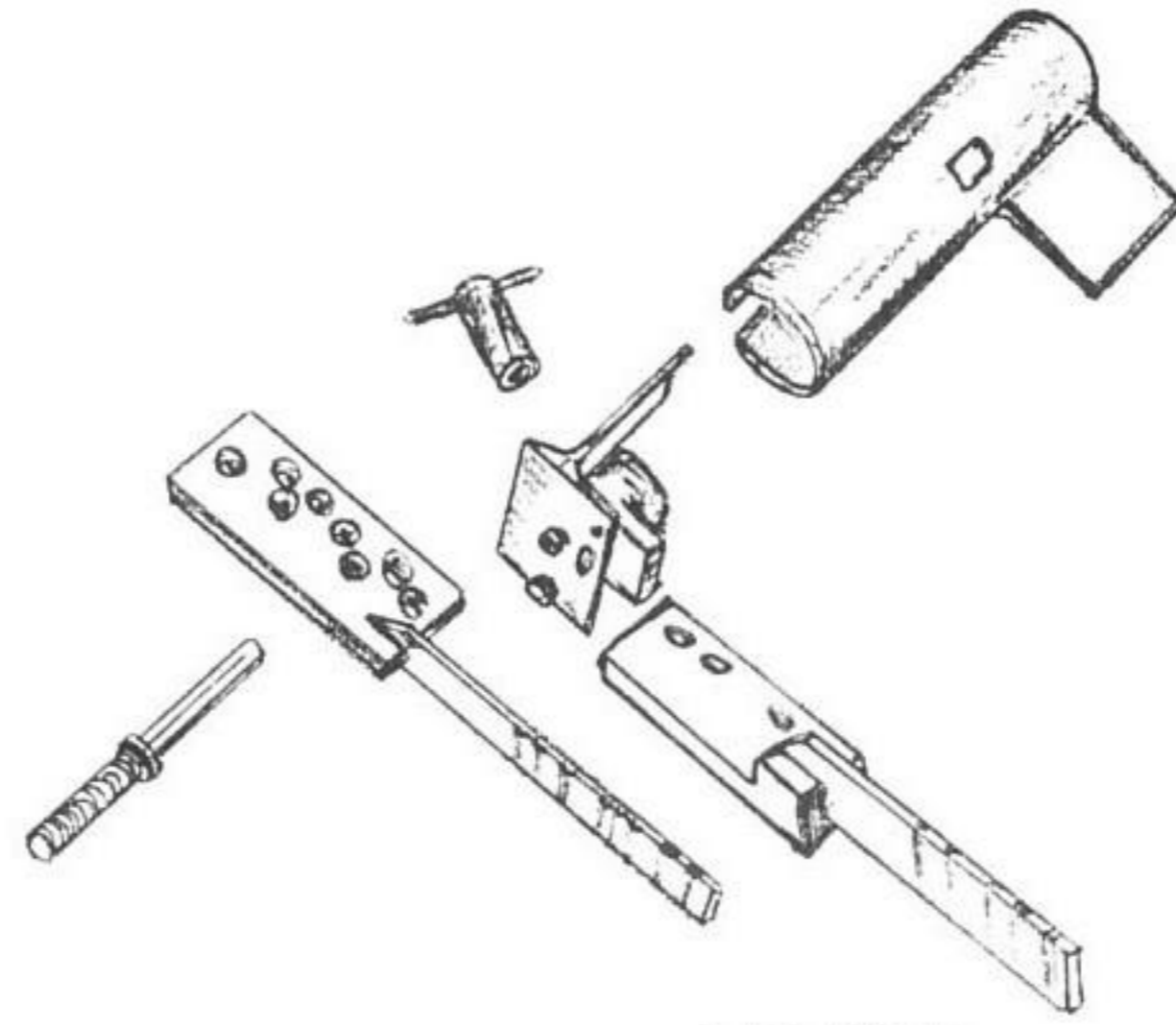

US 280

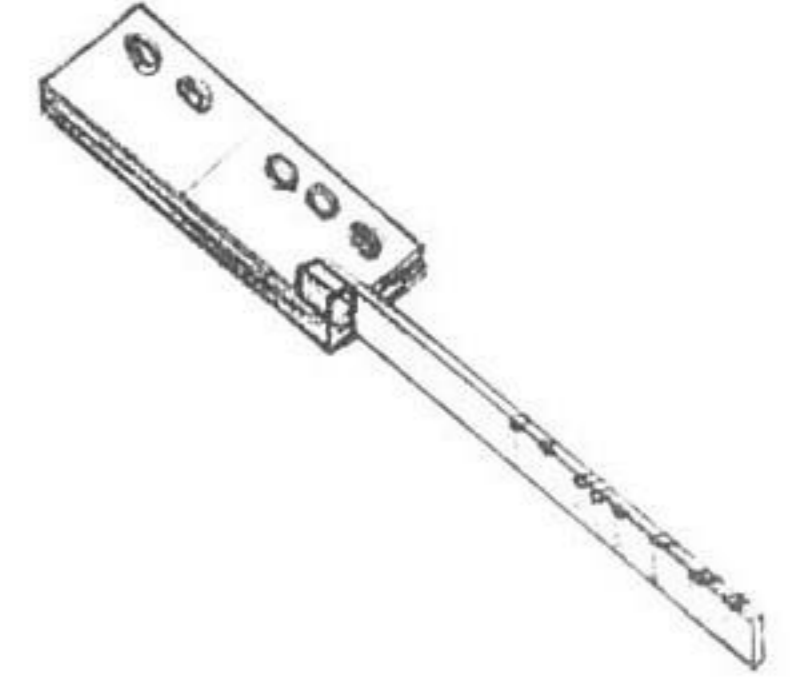

US 280-8

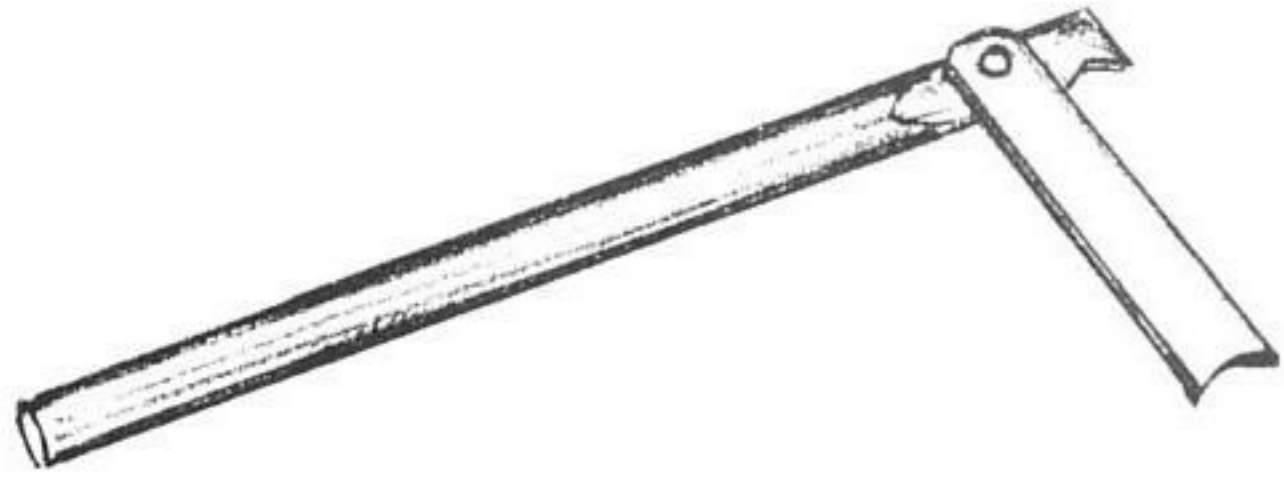

US 281

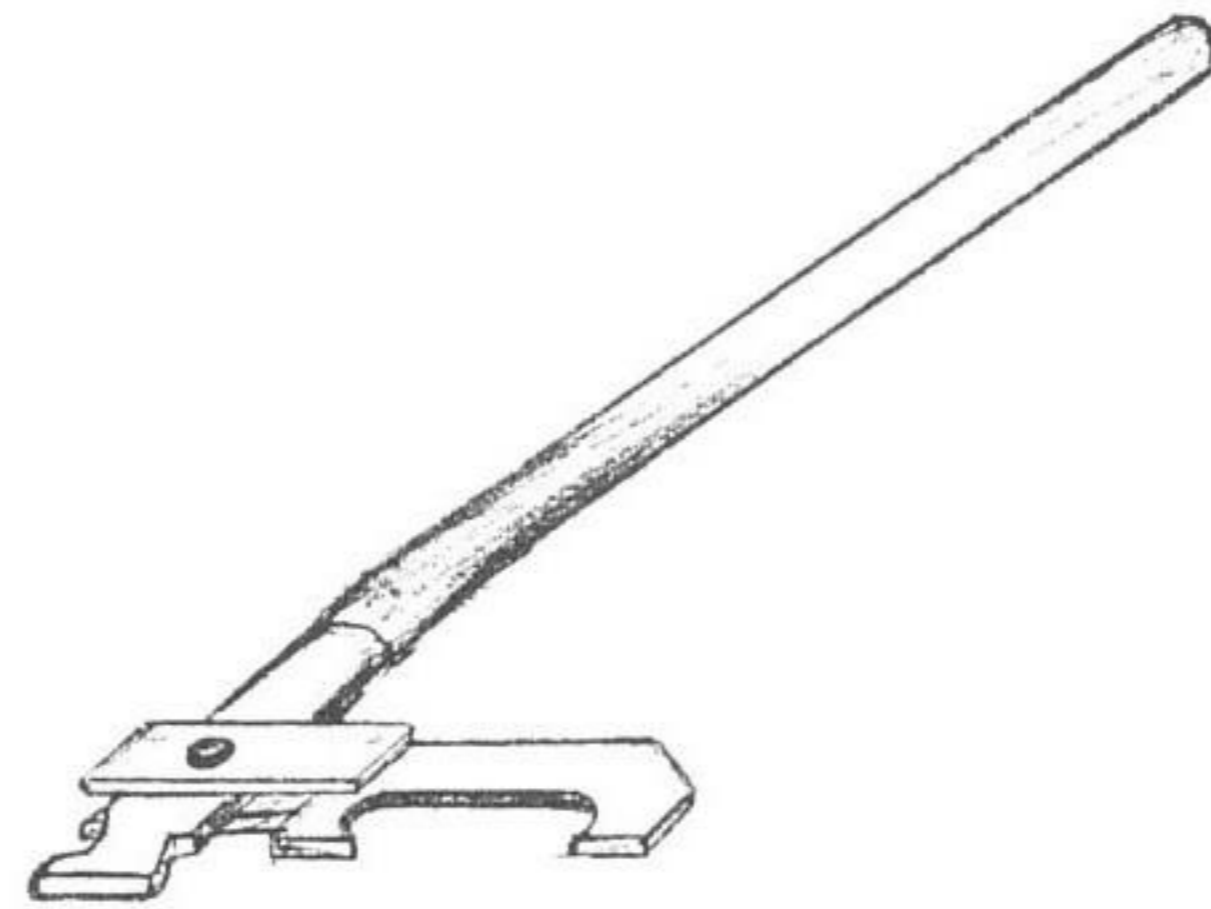

US 281 A

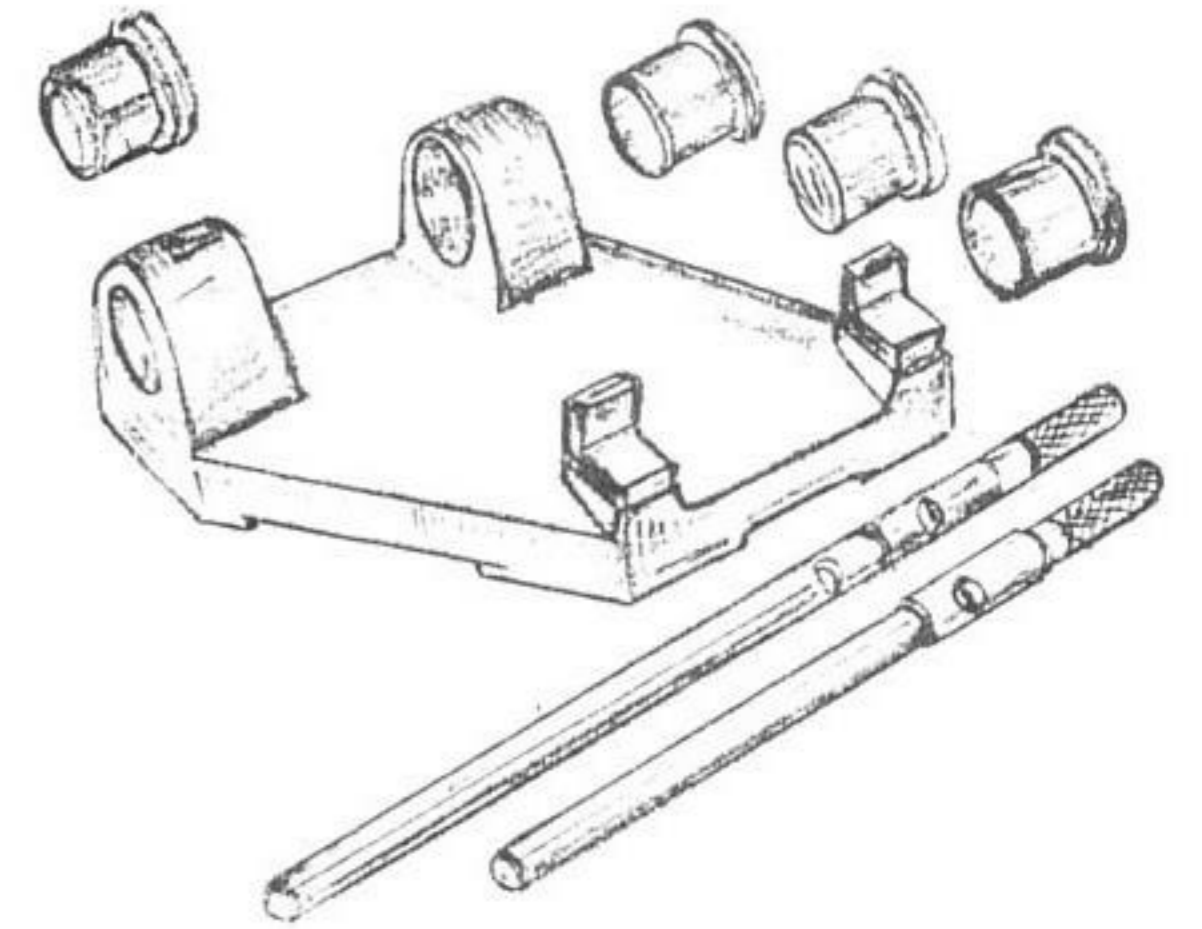

US 282 B



US 282 B-3



US 282 B-5

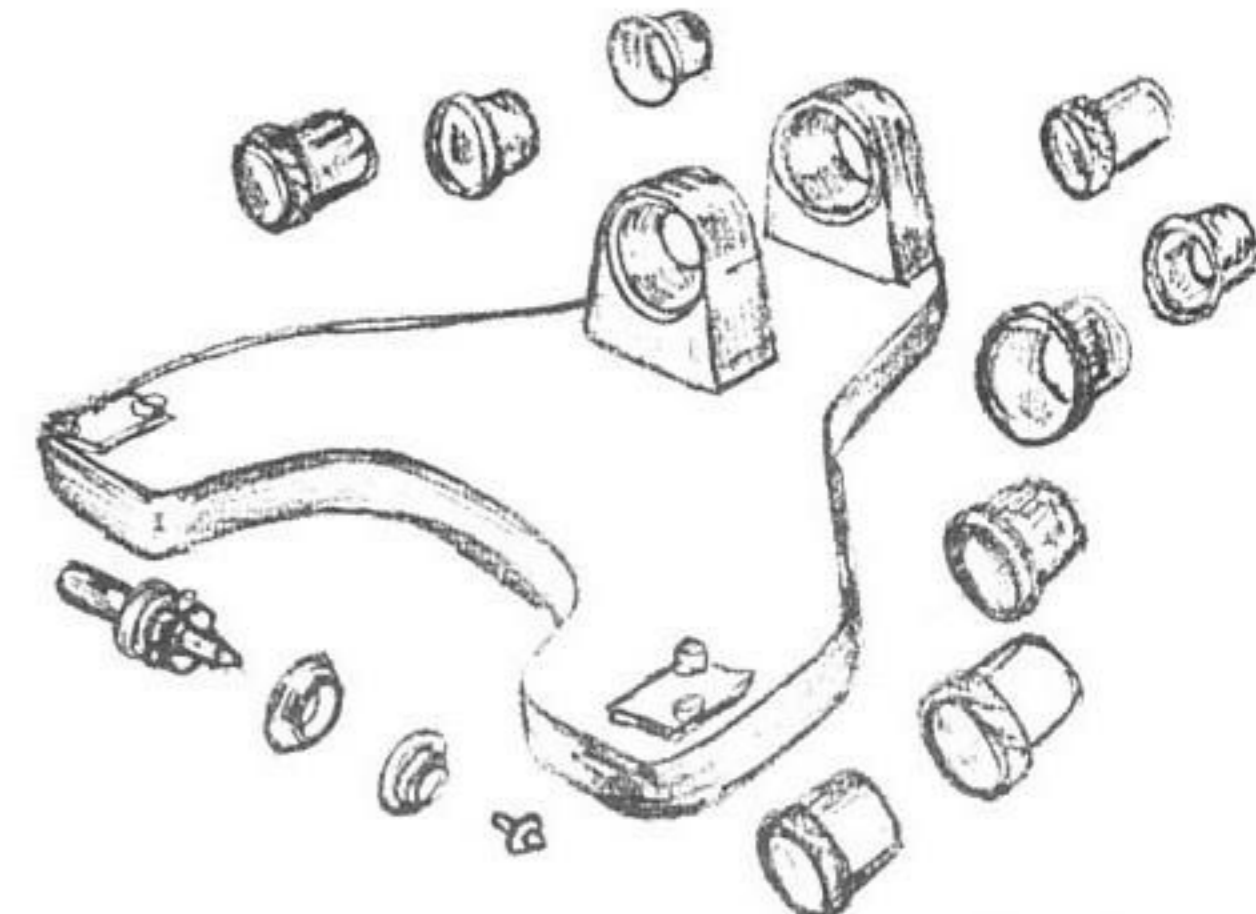

US 282 D

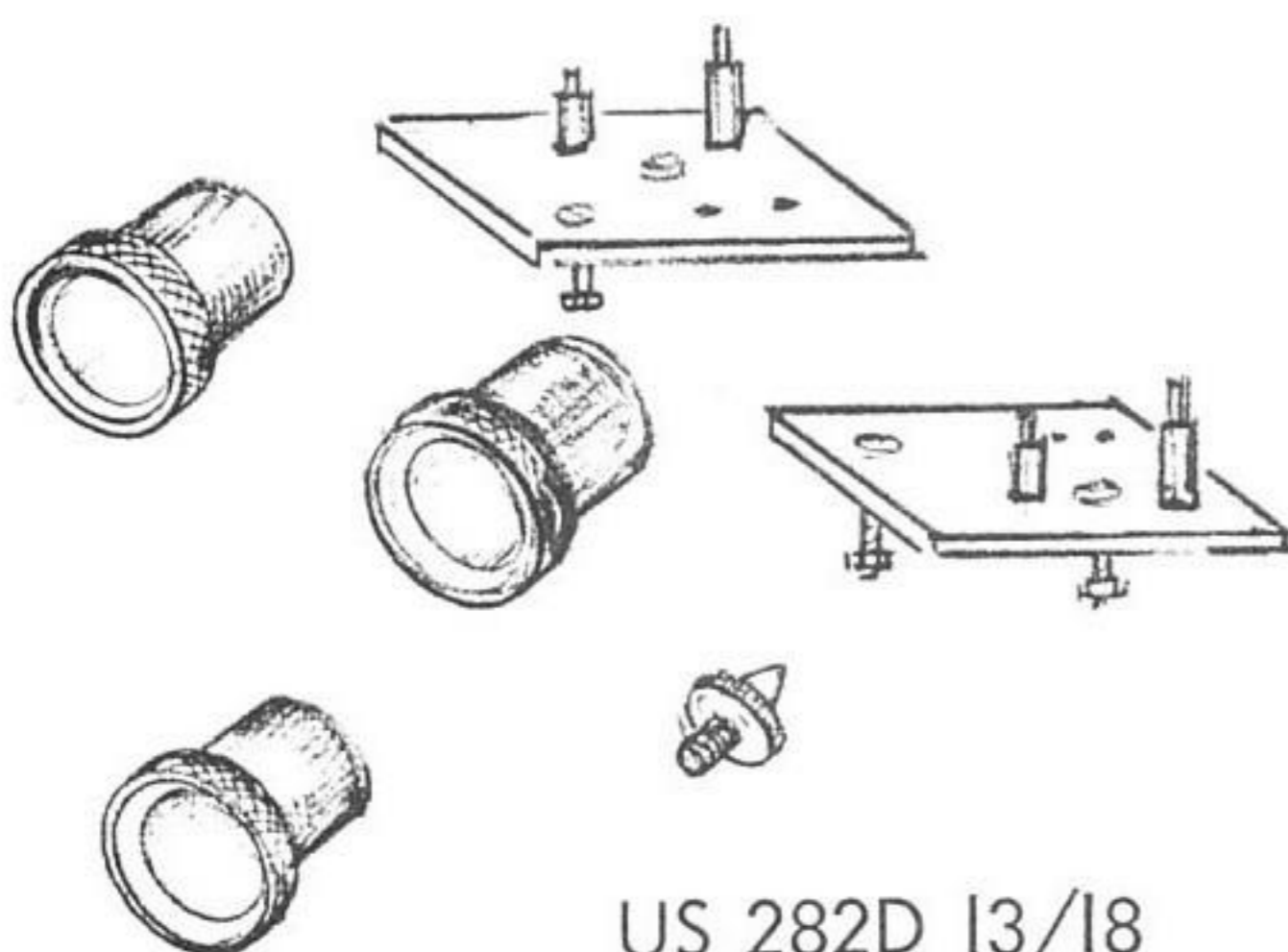

US 282D 13/18

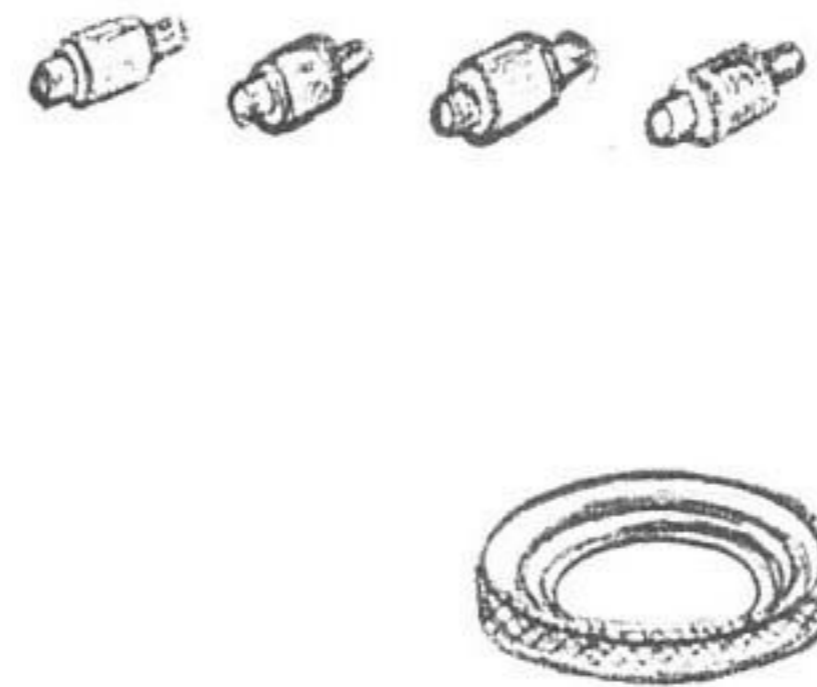

US 282 D/50

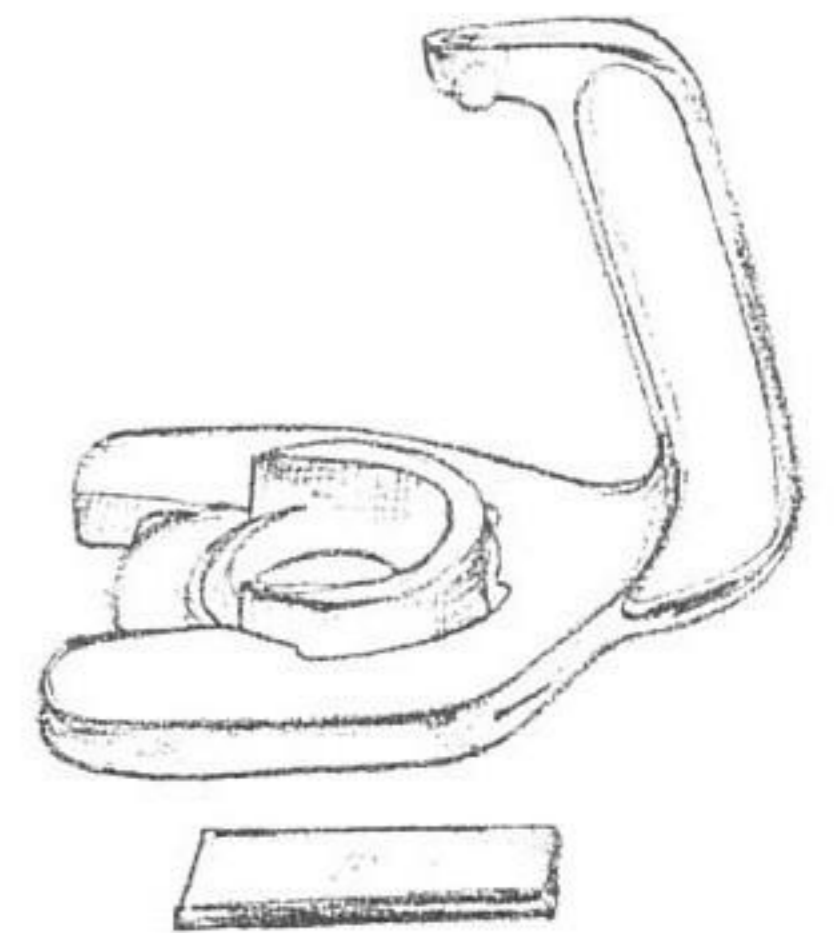

US 287 A

Special TOOLS

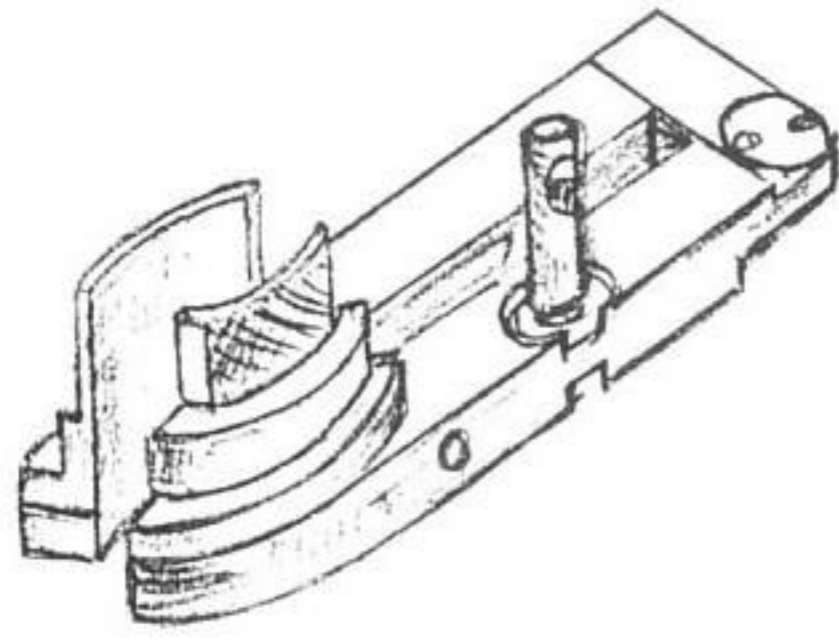

US 288 B

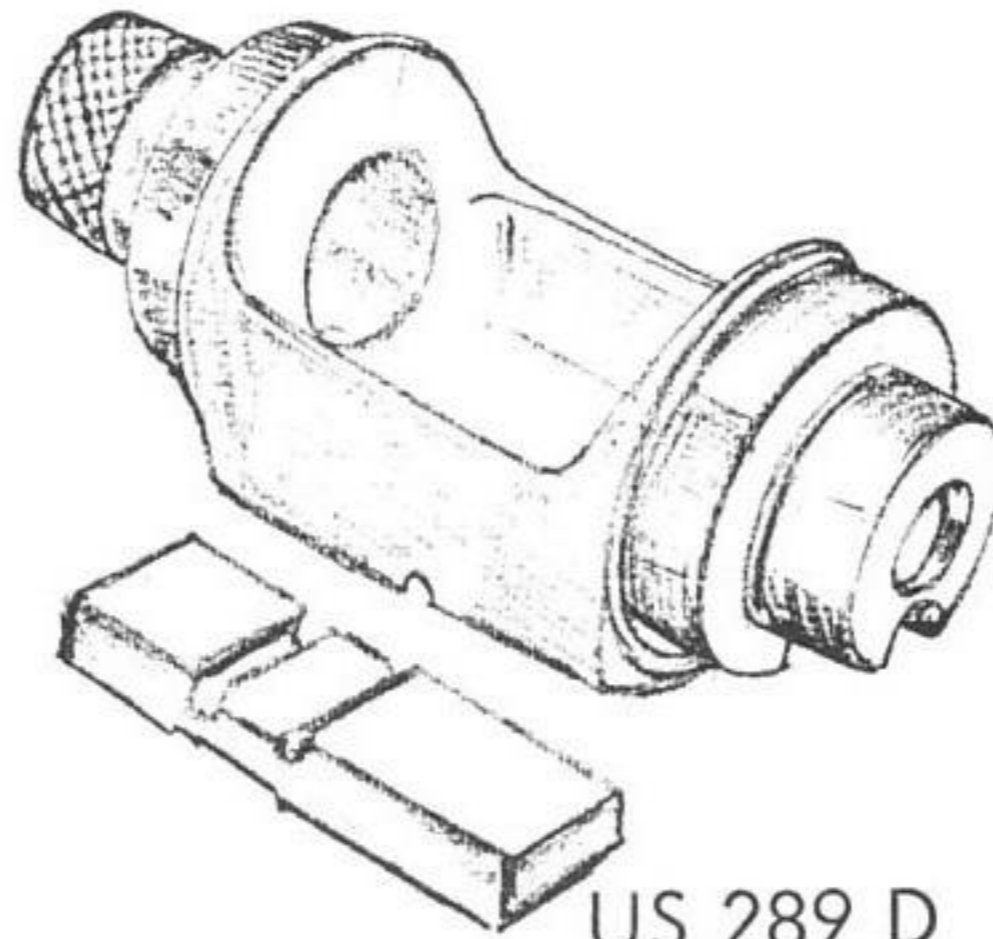

US 289 D

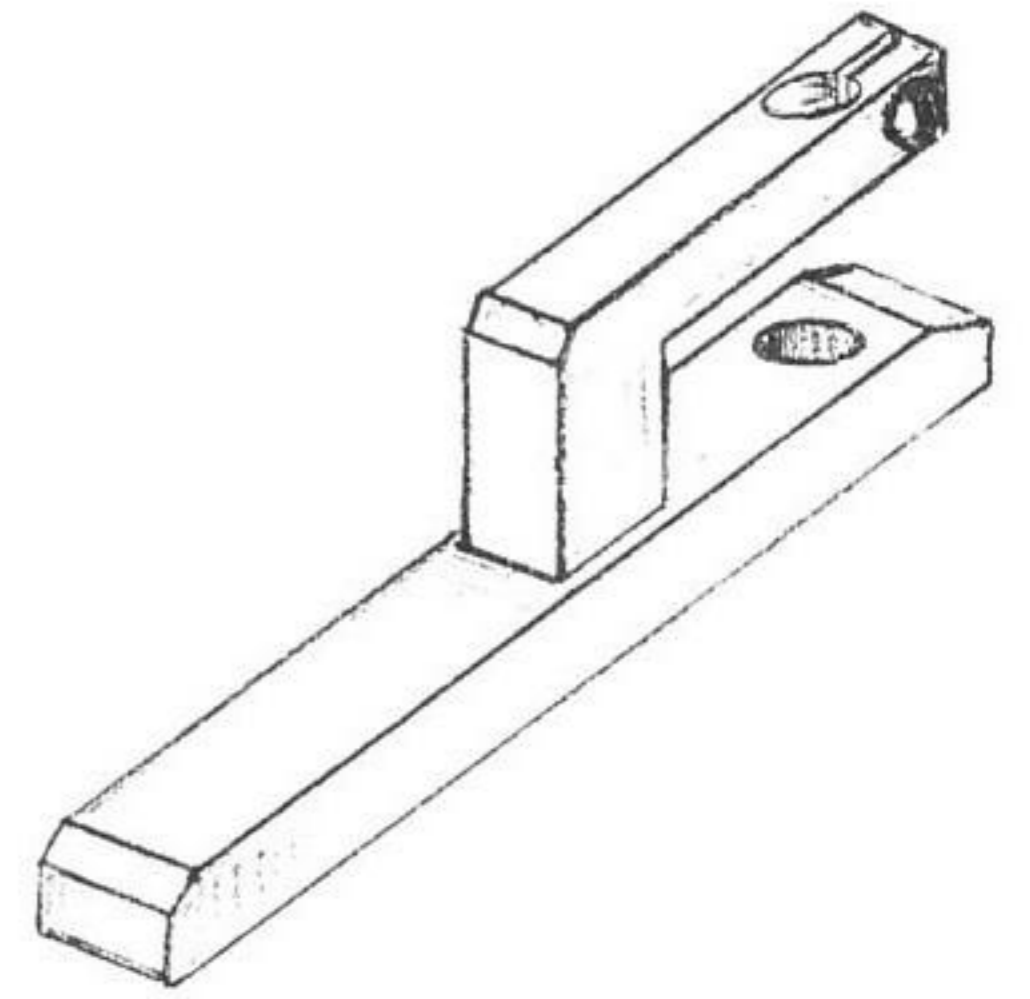

US 292

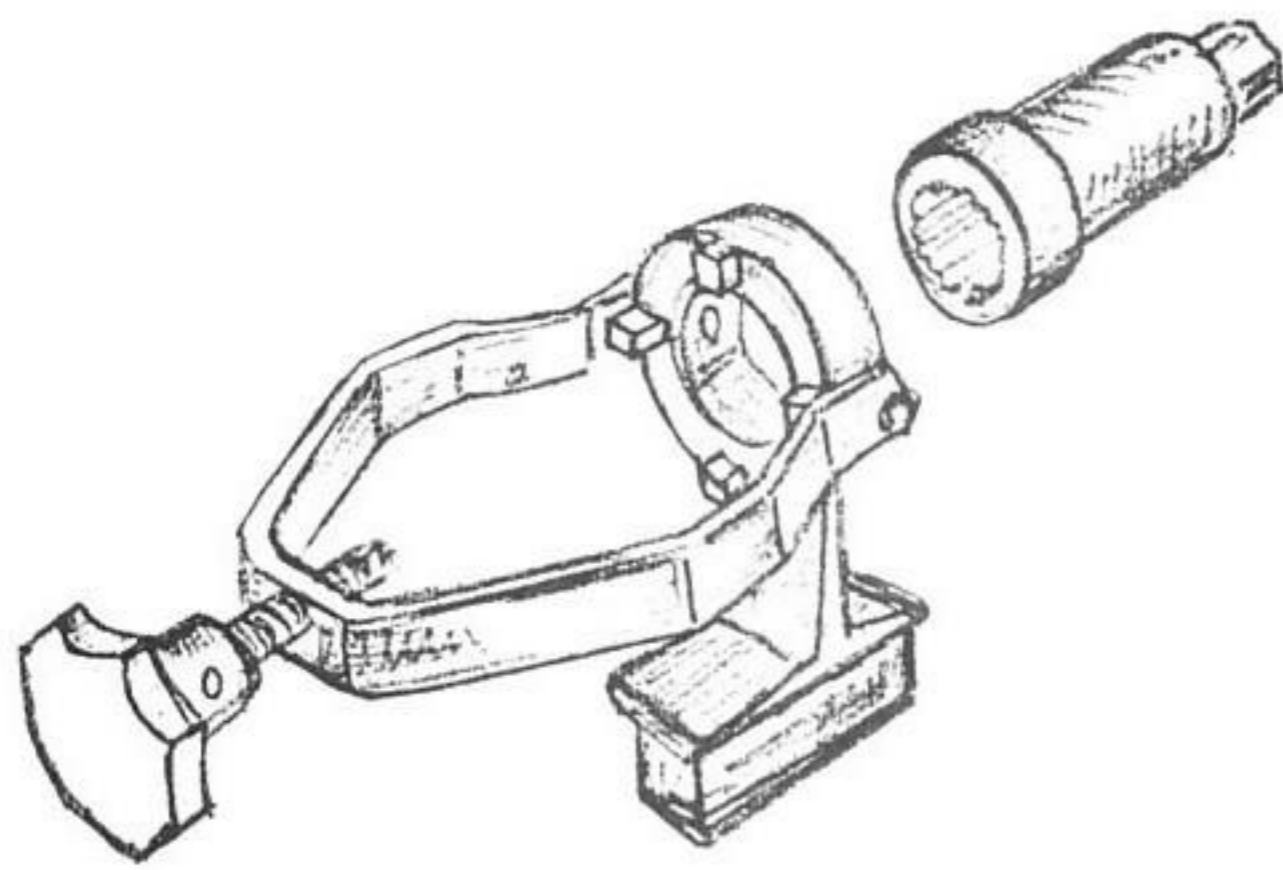

US 293

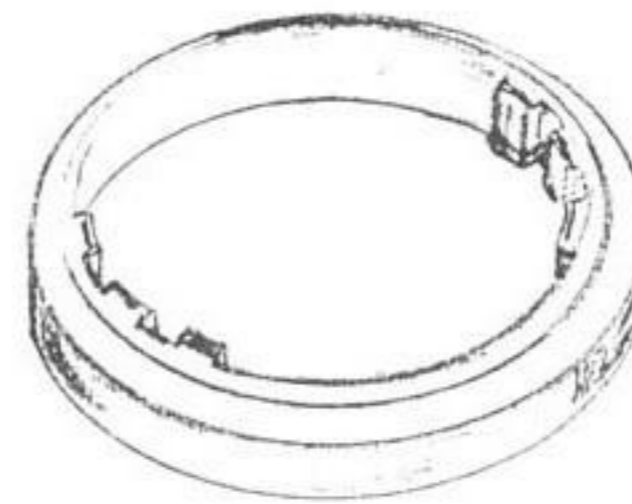

US 293/104

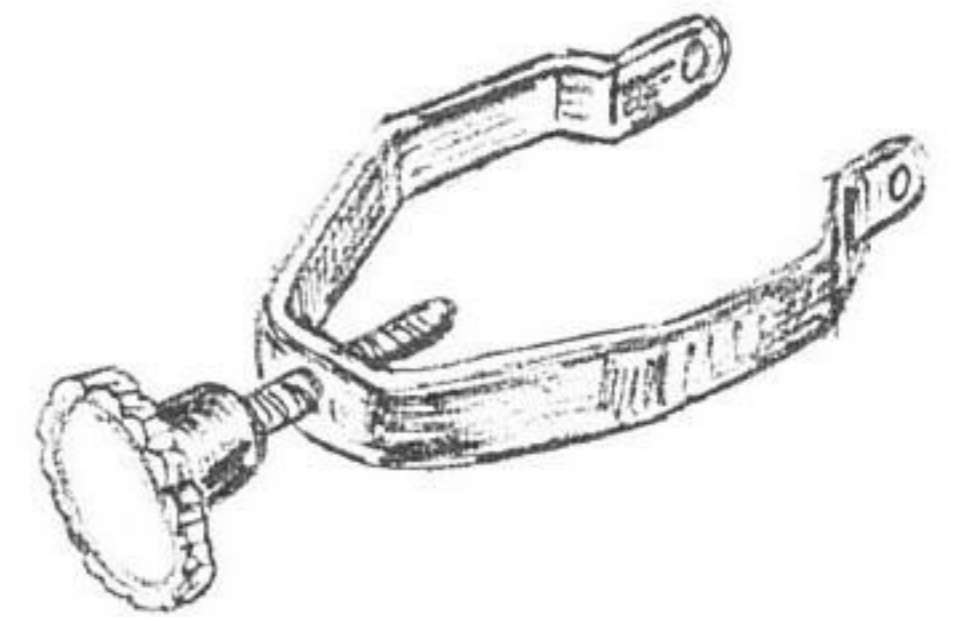

US 293/50

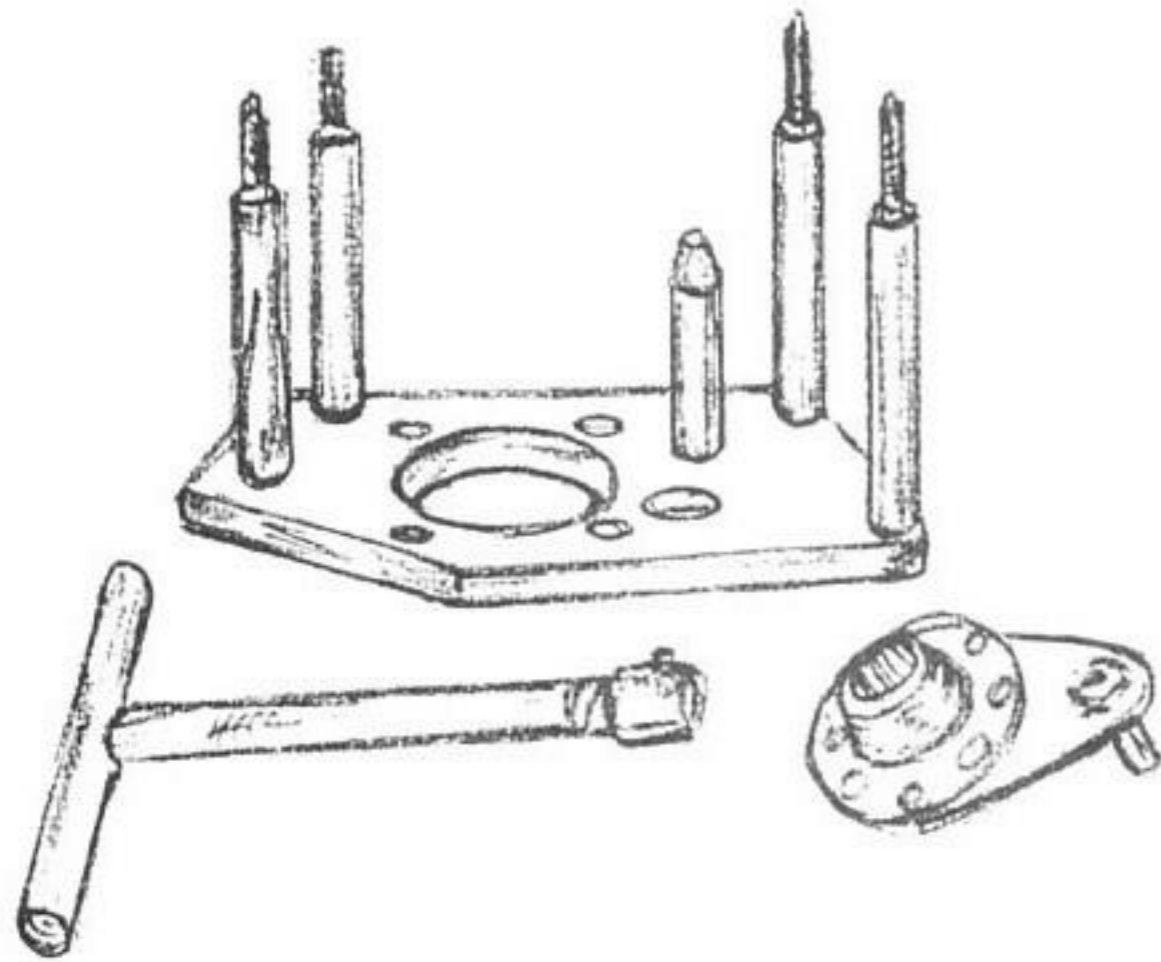

US 294



US 294 A/50

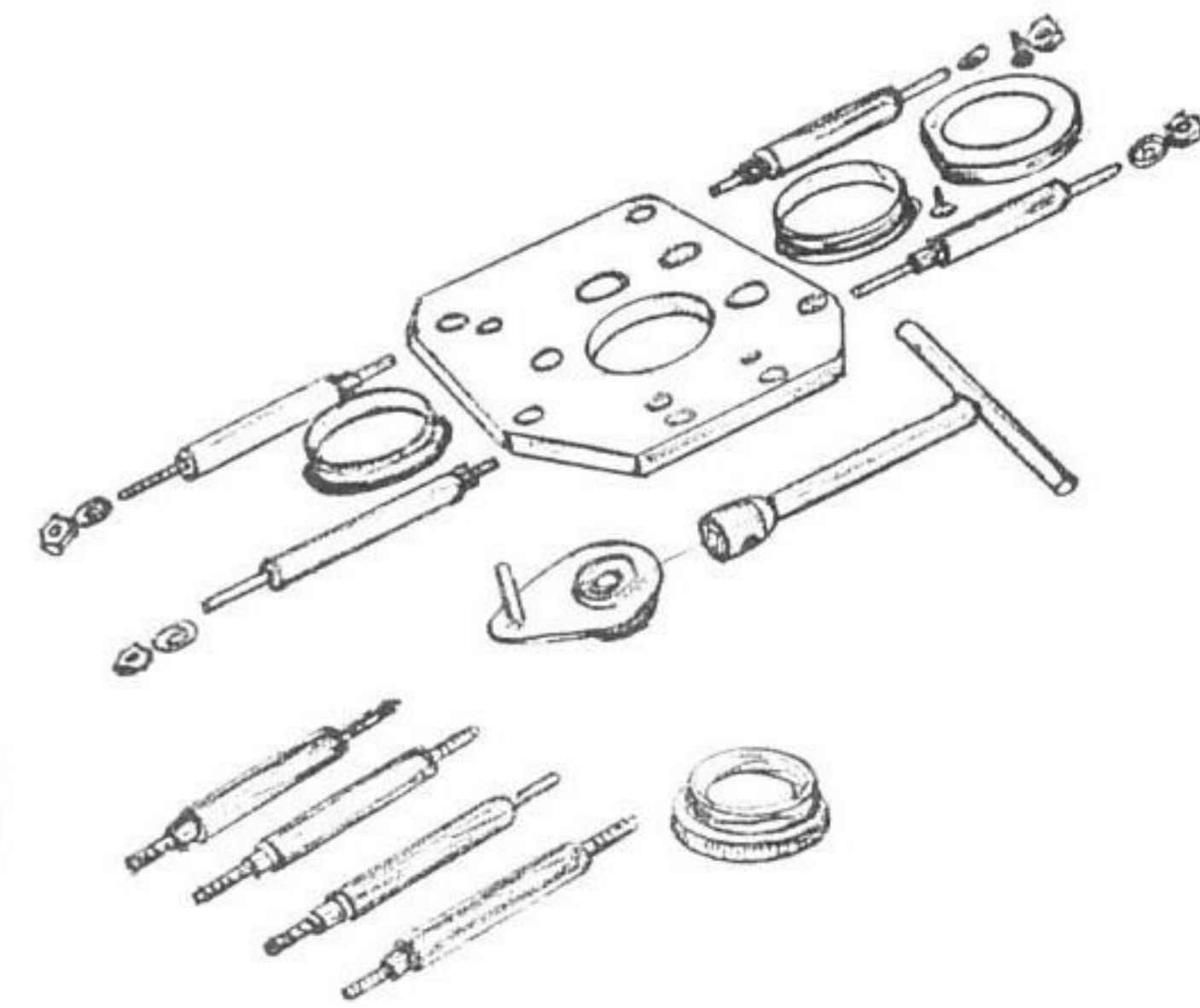

US 294 B



US 295

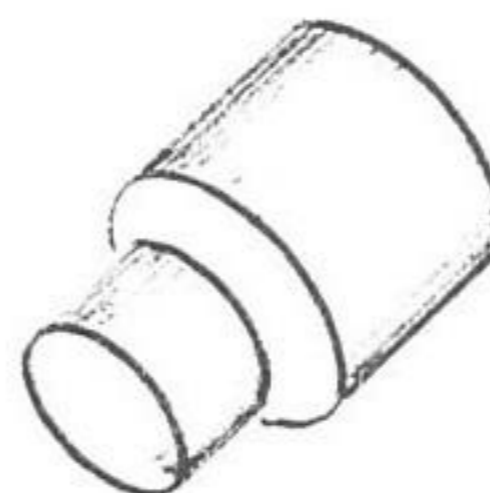

US 295 A

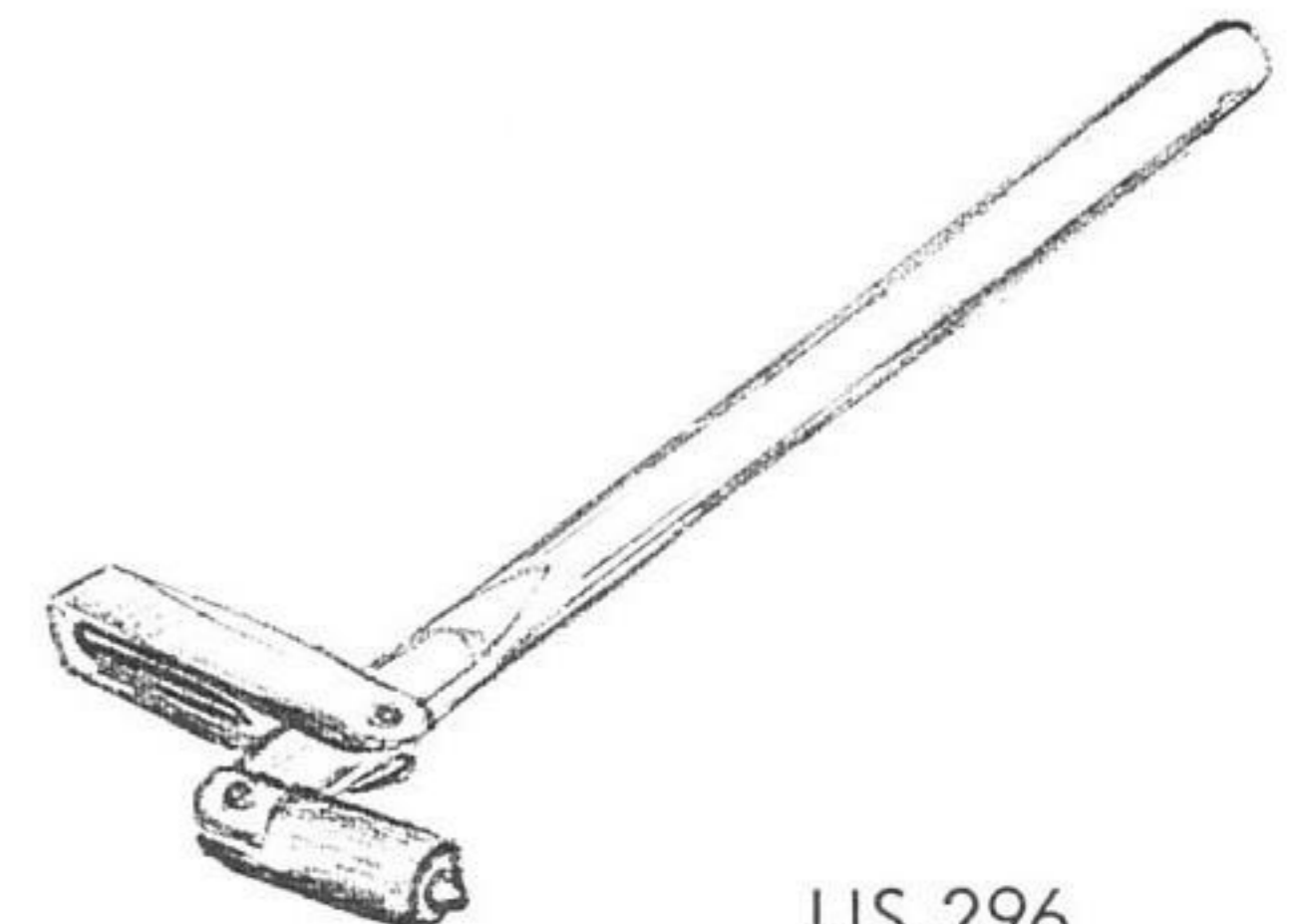

US 296



Special TOOLS

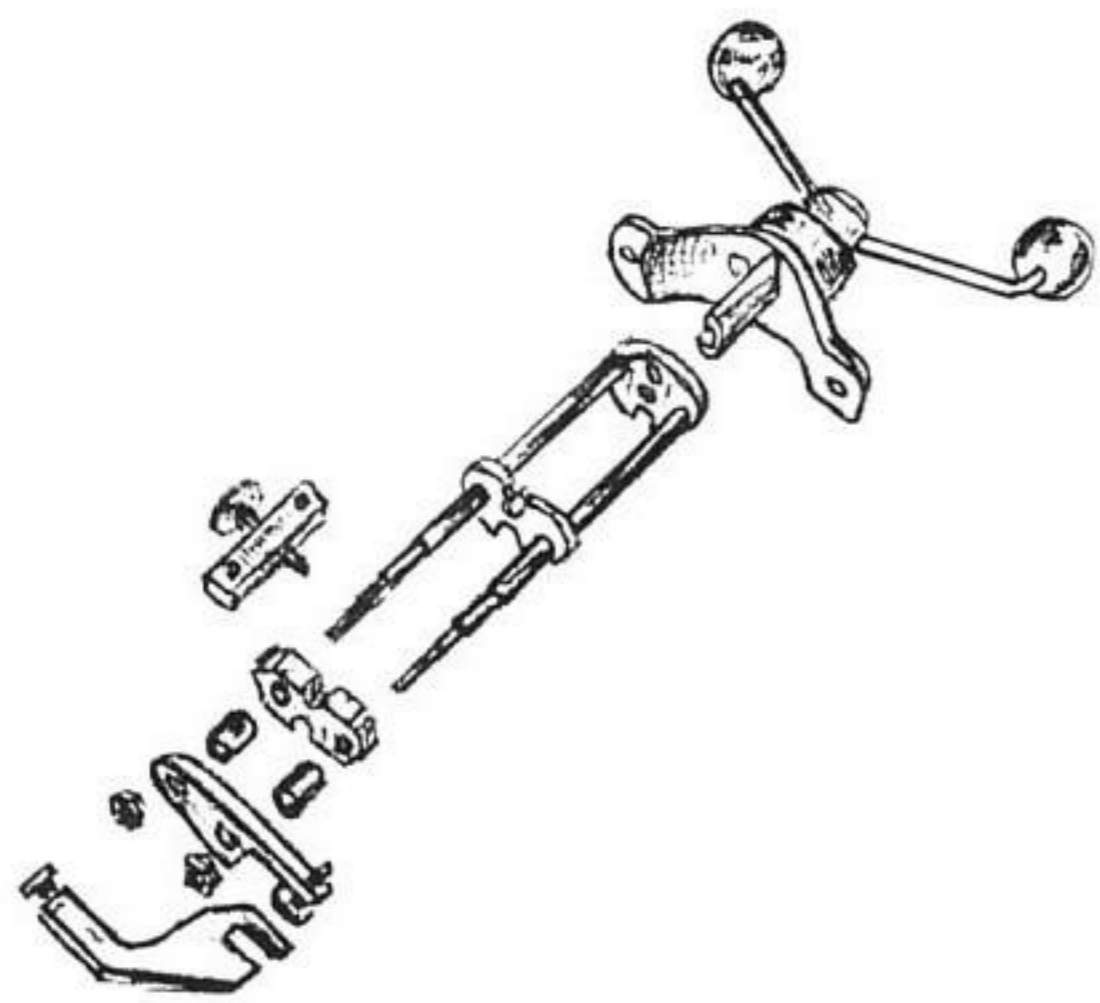

US 297

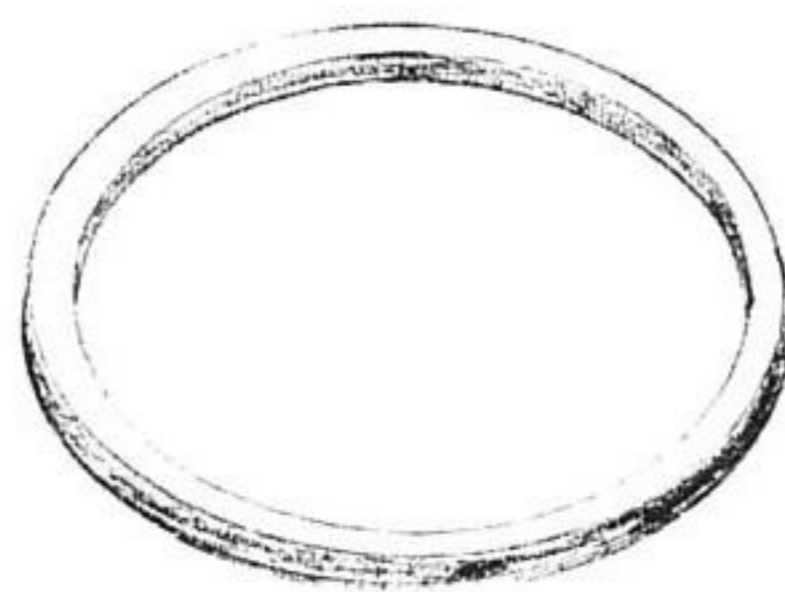

US 298

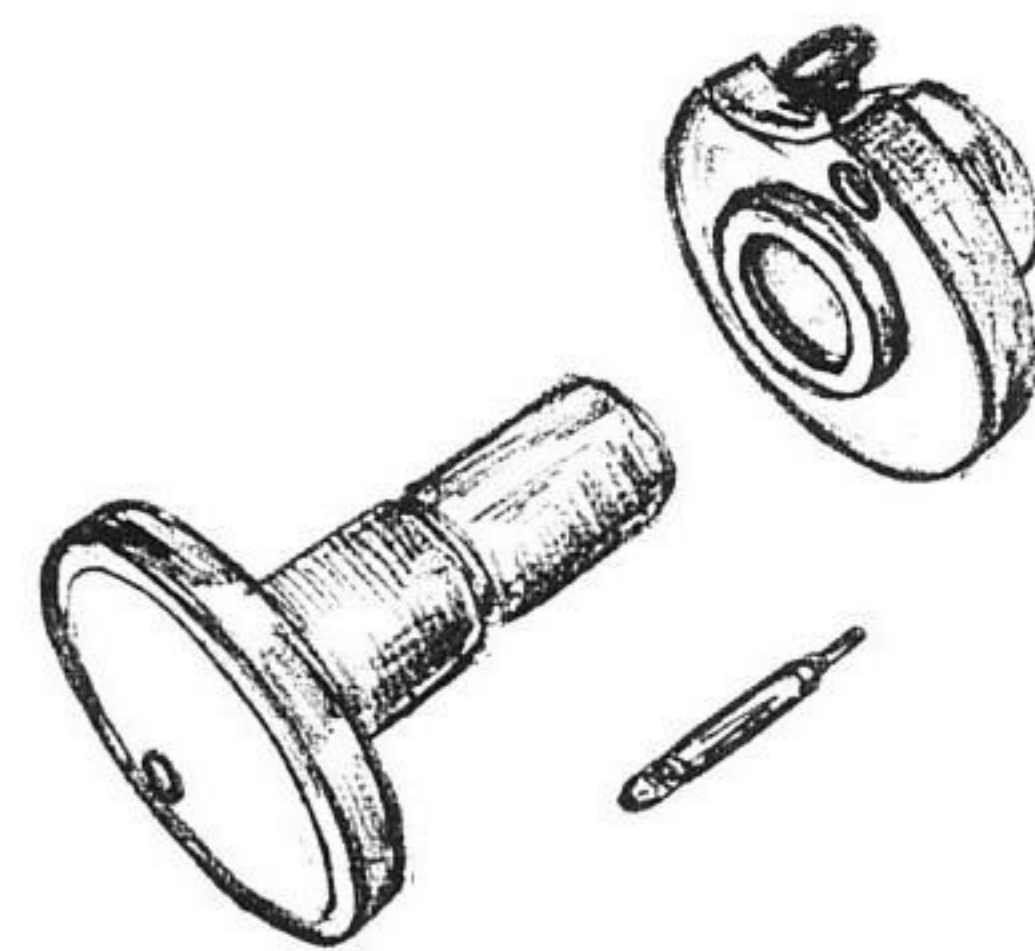

US 299

Special TOOLS

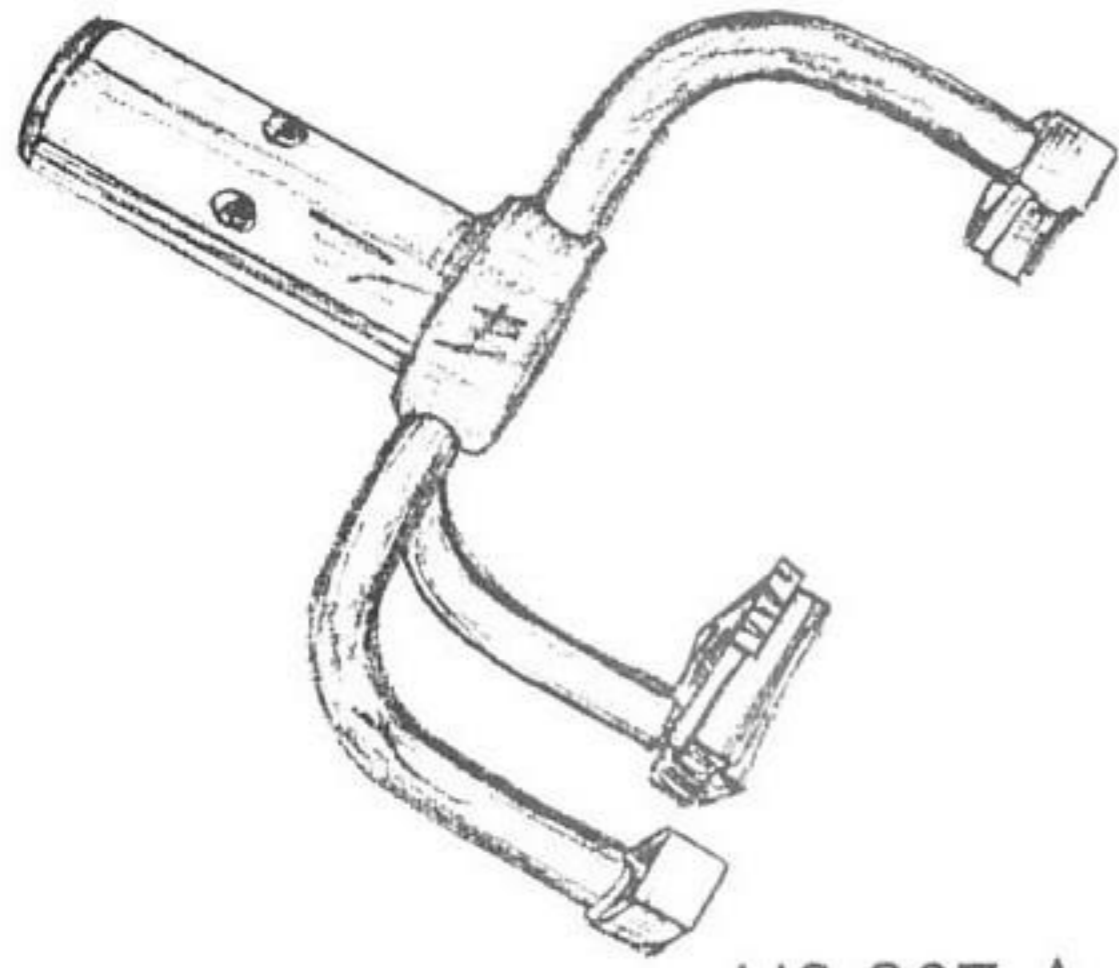

US 307 A

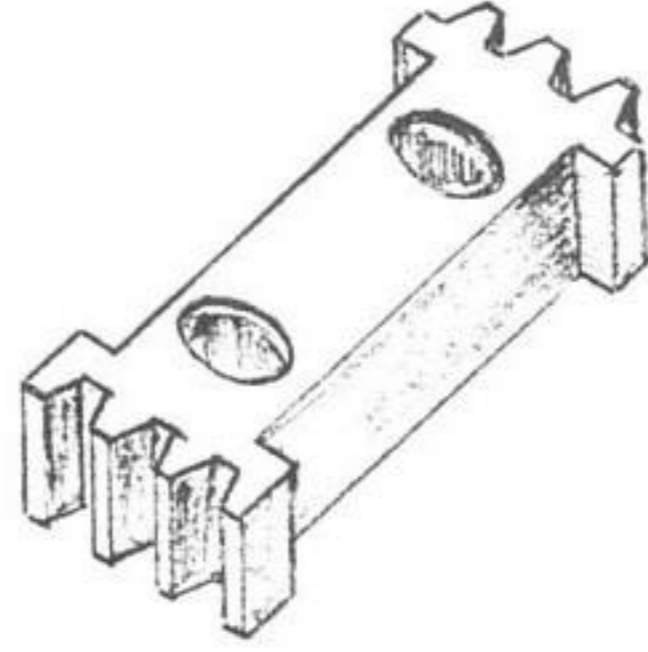

US 307 A-7

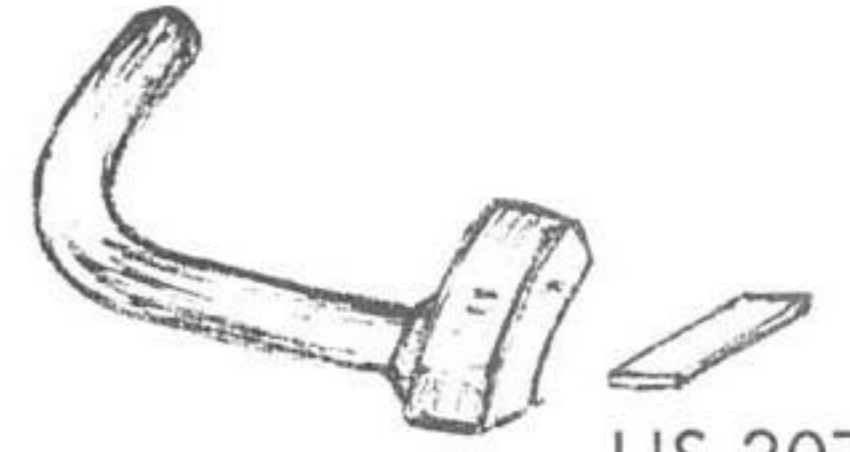

US 307 A-20

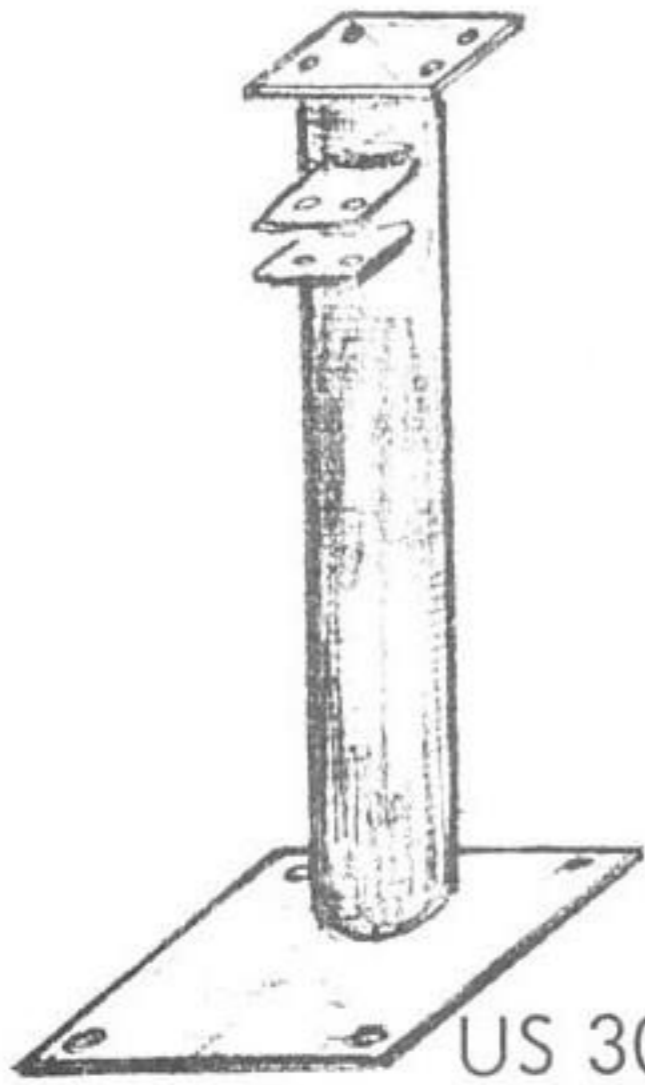

US 308

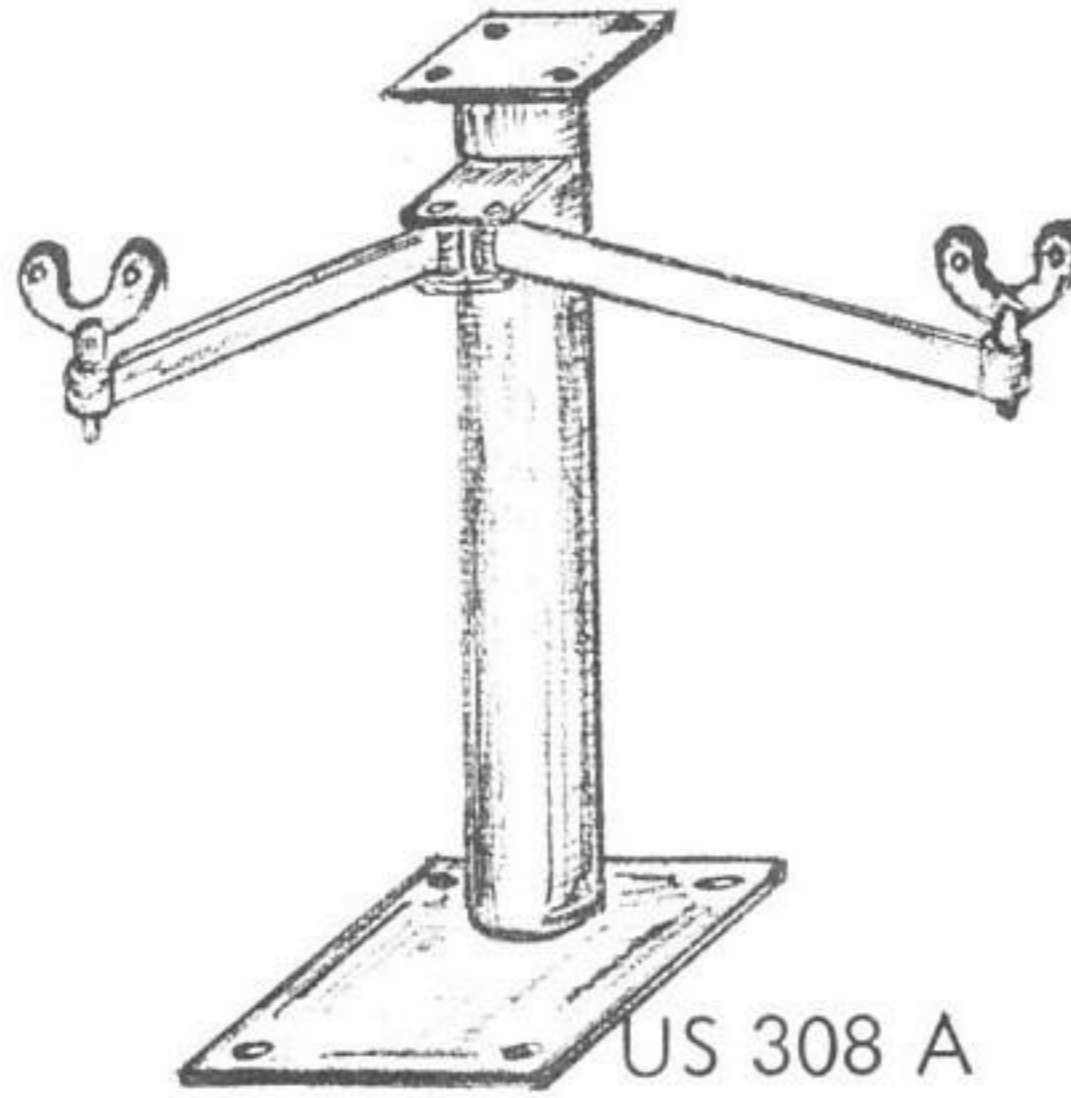

US 308 A

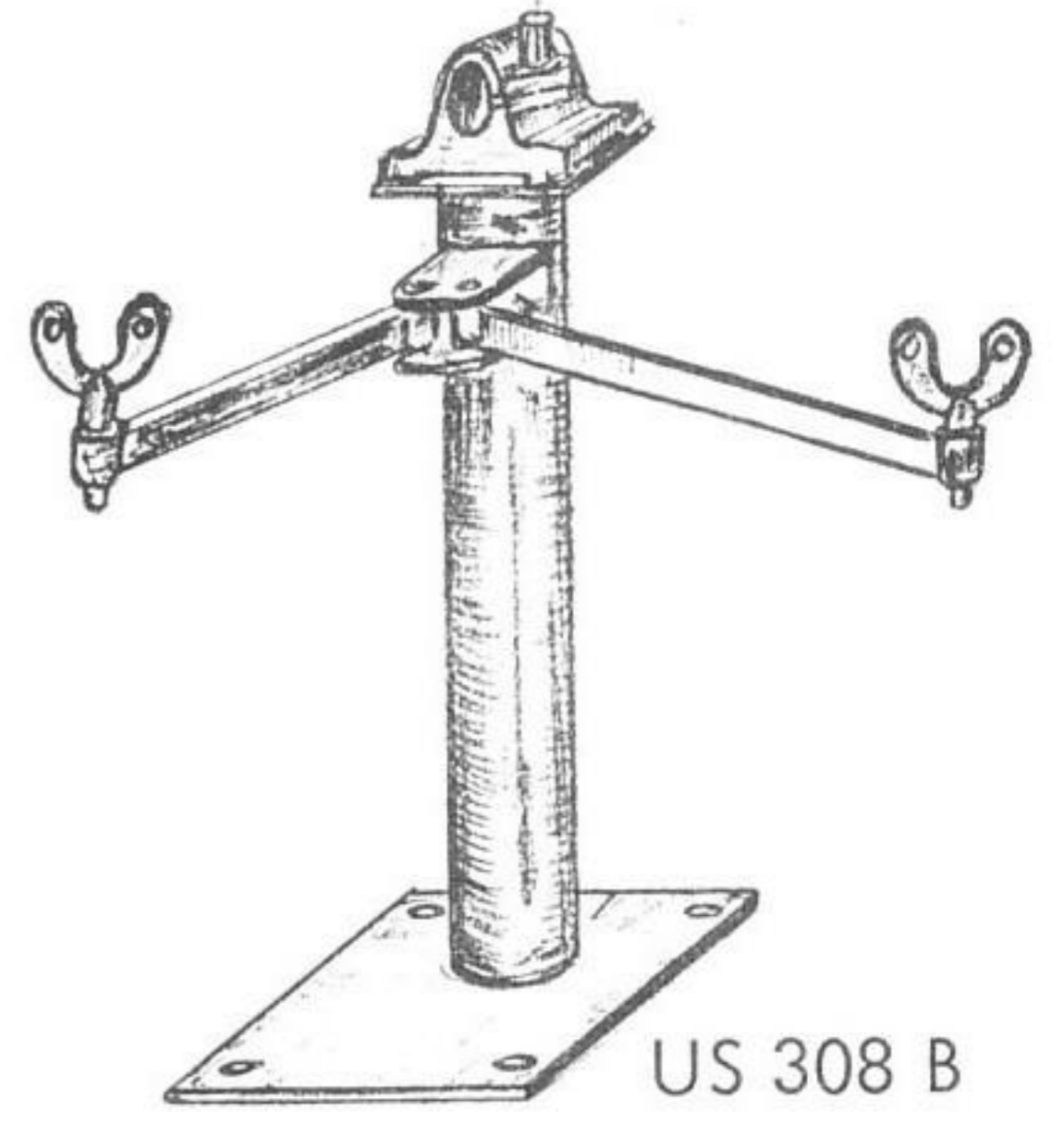

US 308 B

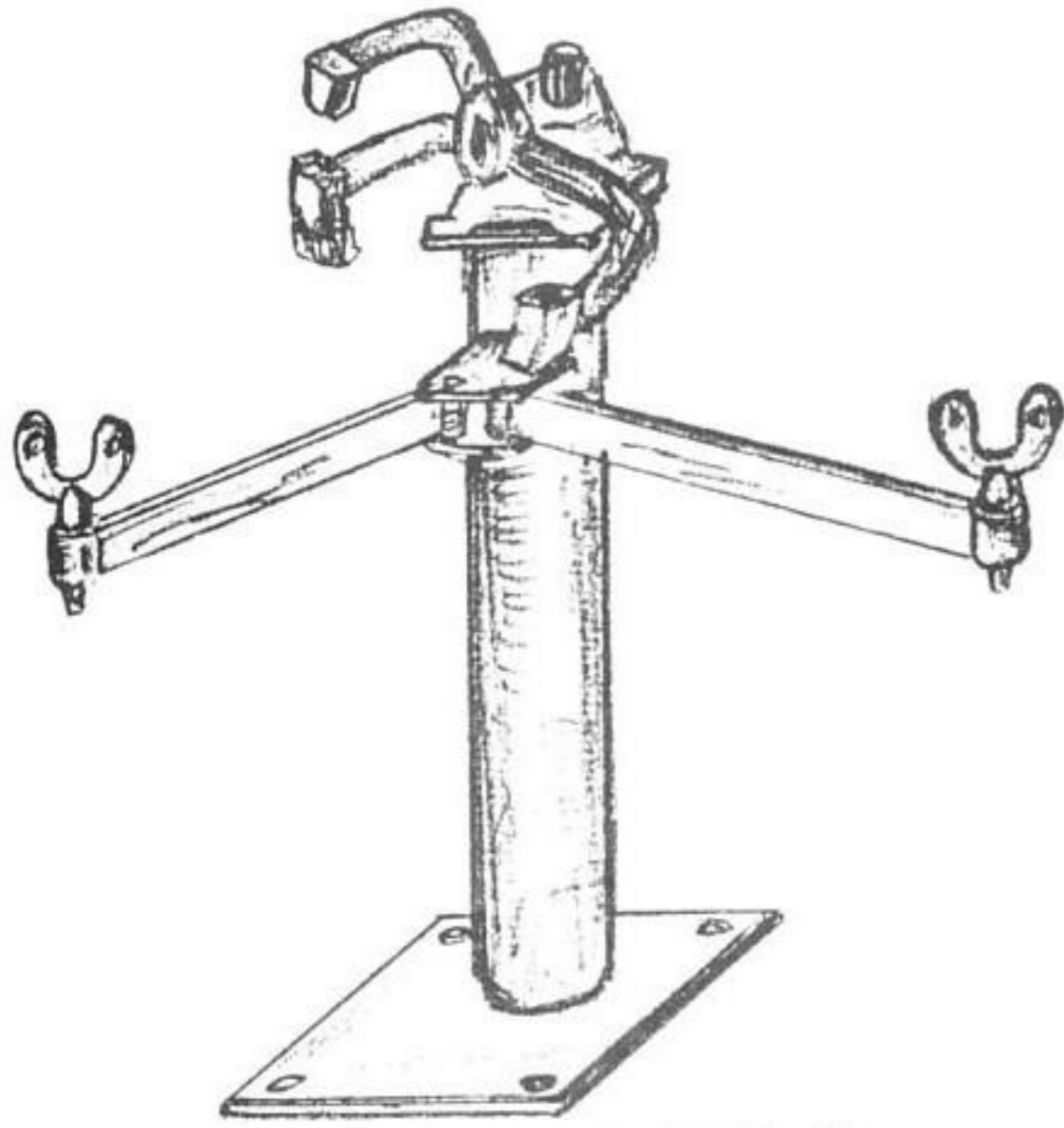

US 308 C

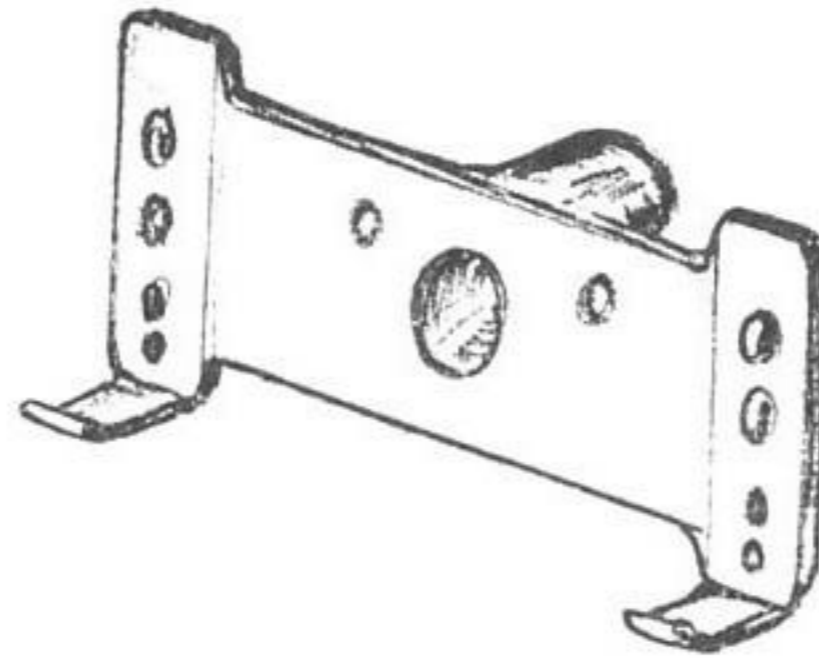

US 309

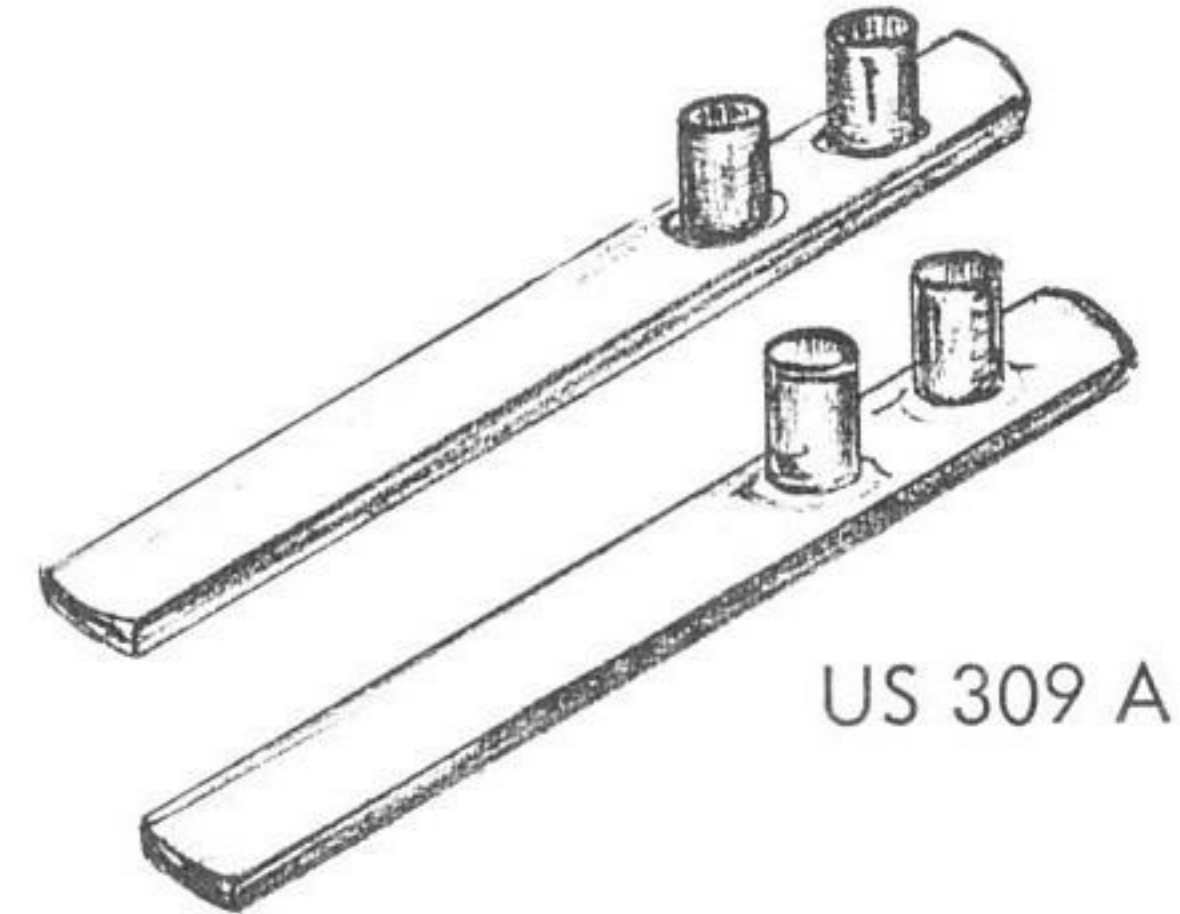

US 309 A

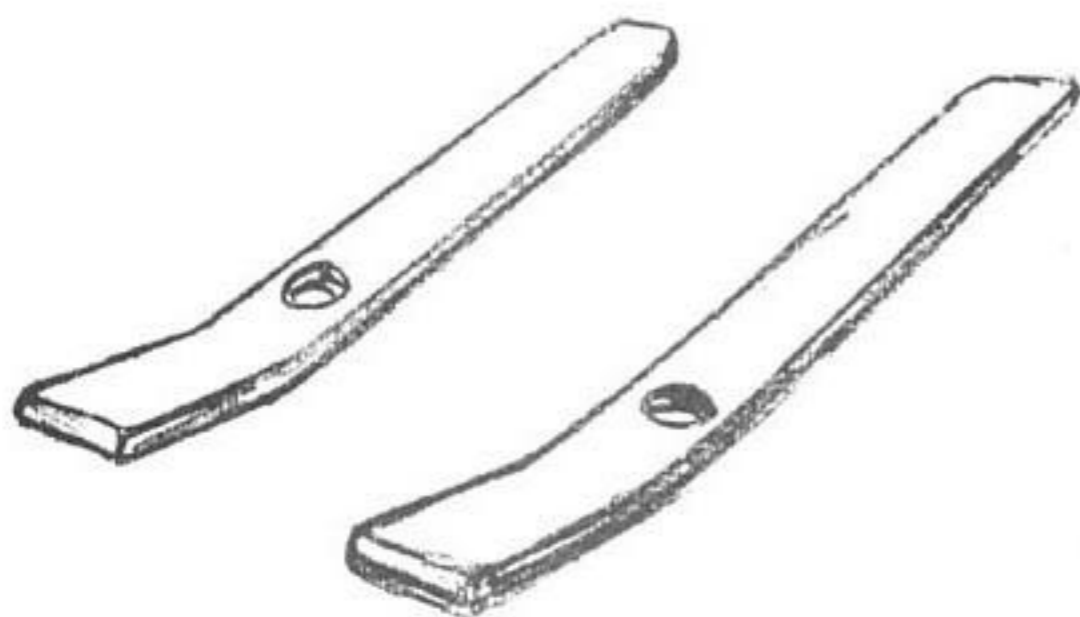

US 309 B

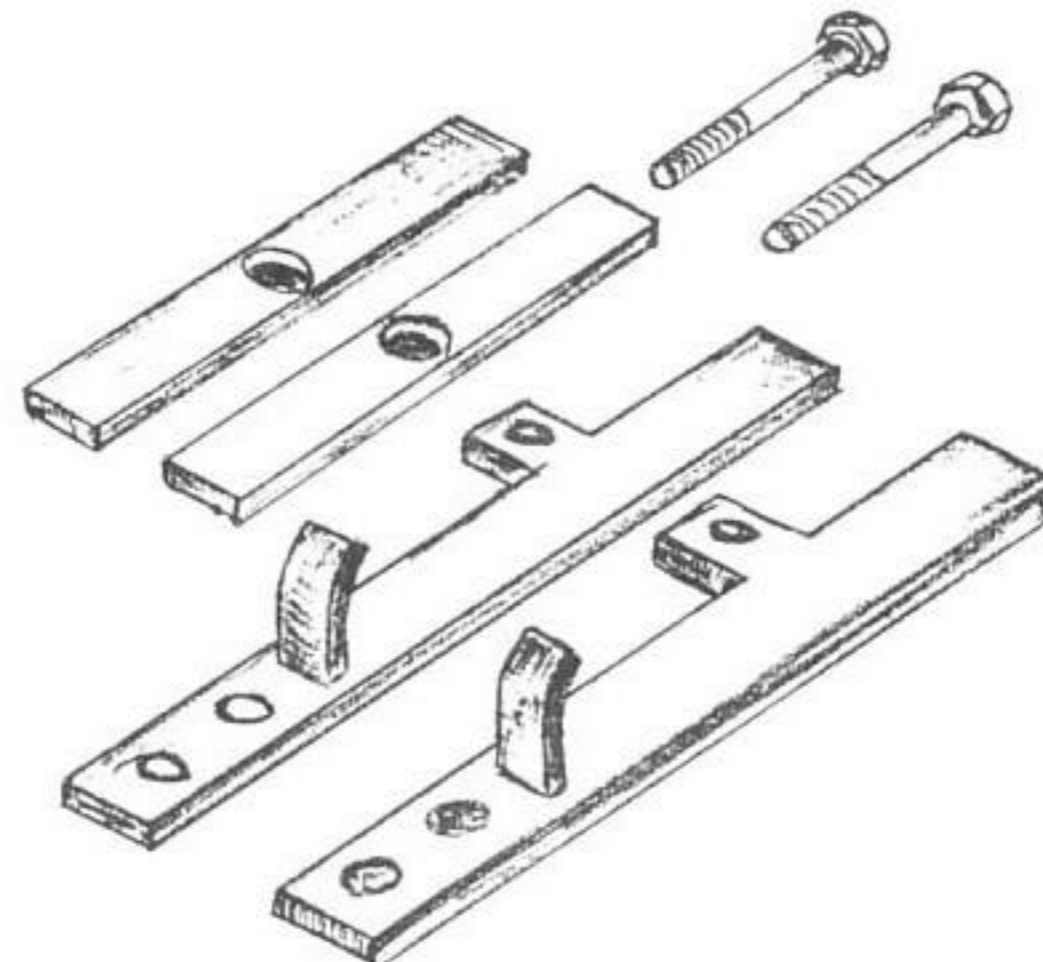

US 309 C

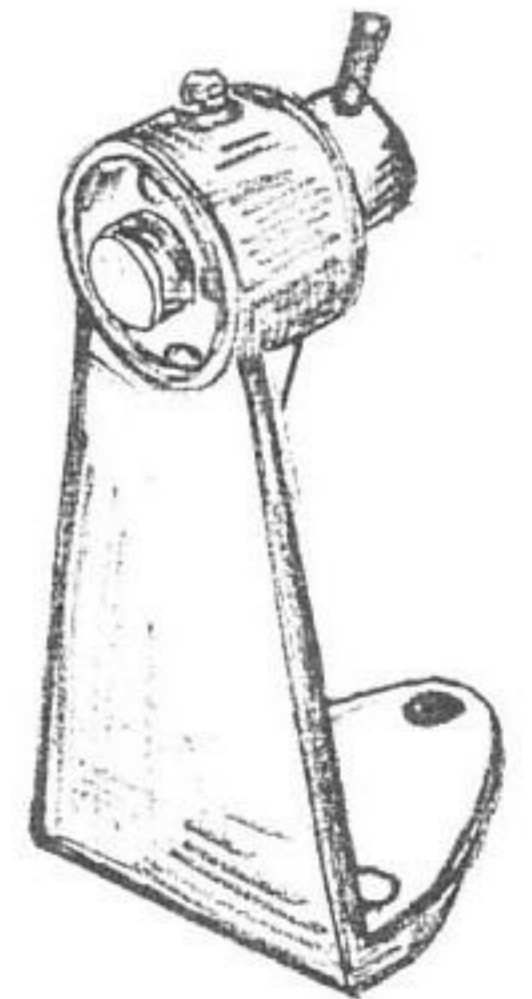

US 310 A



Special TOOLS

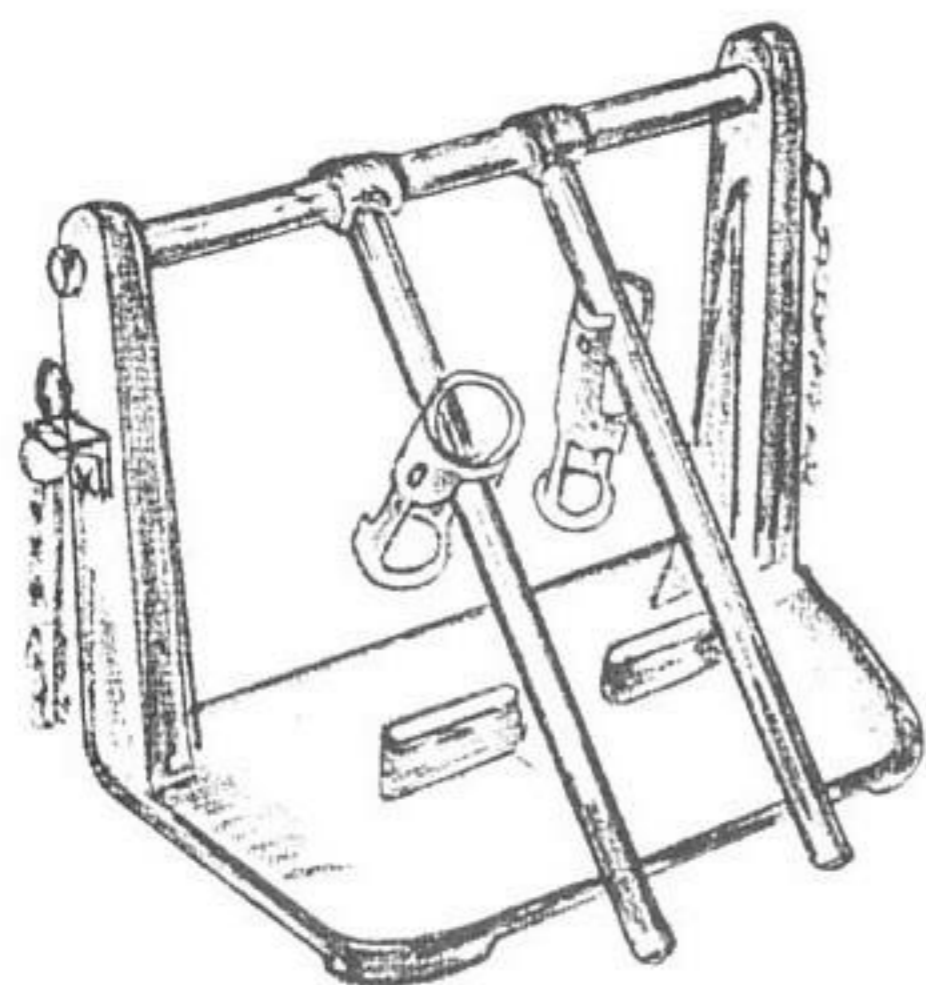

US 311 H

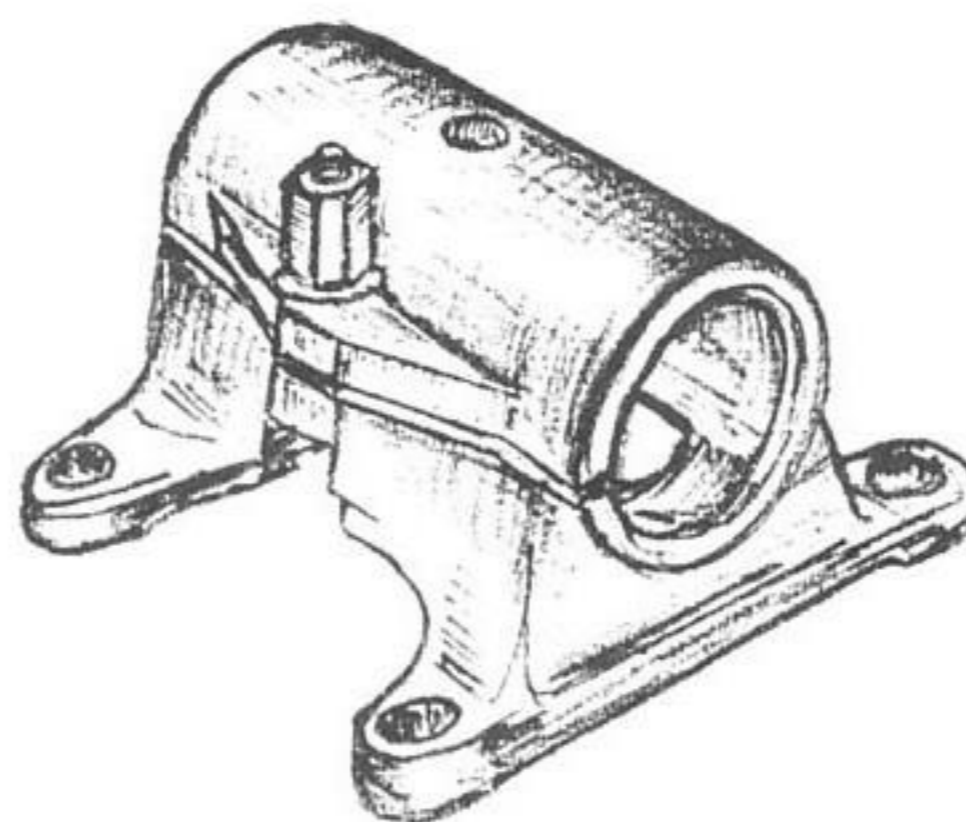

US 313

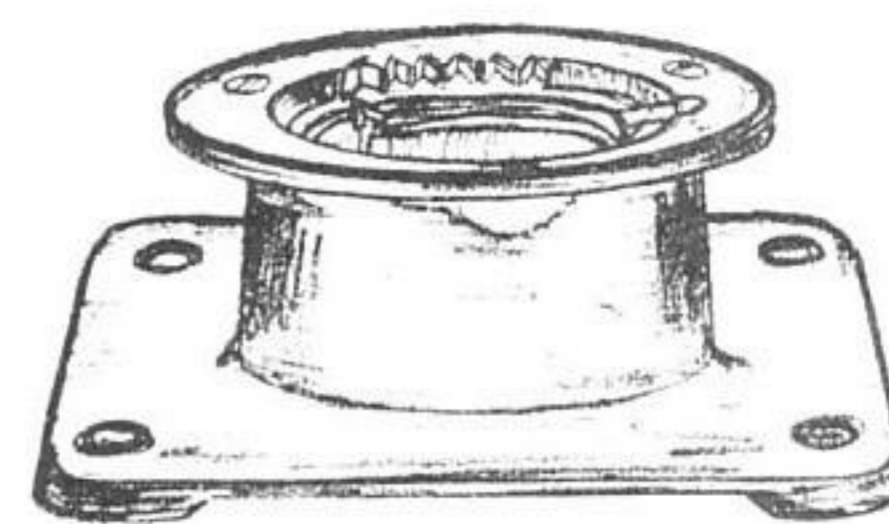

US 314

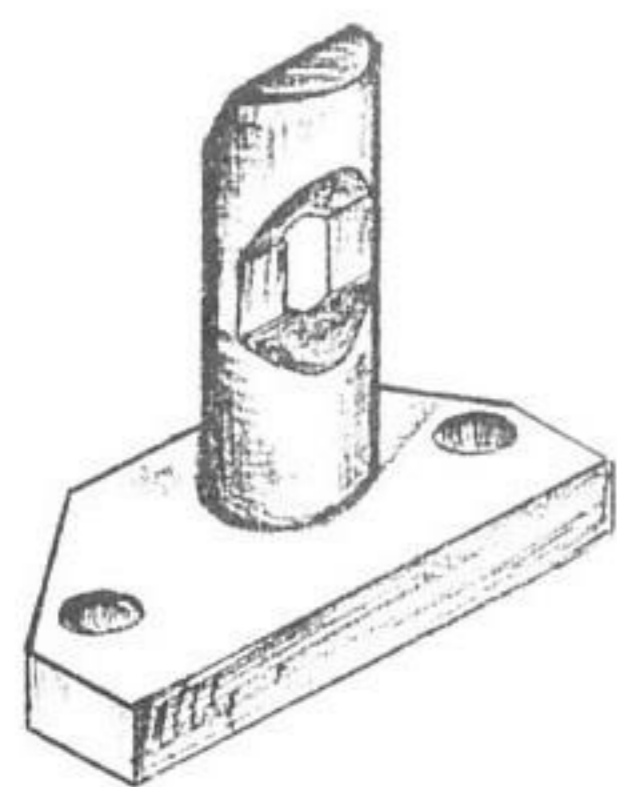

US 328 A

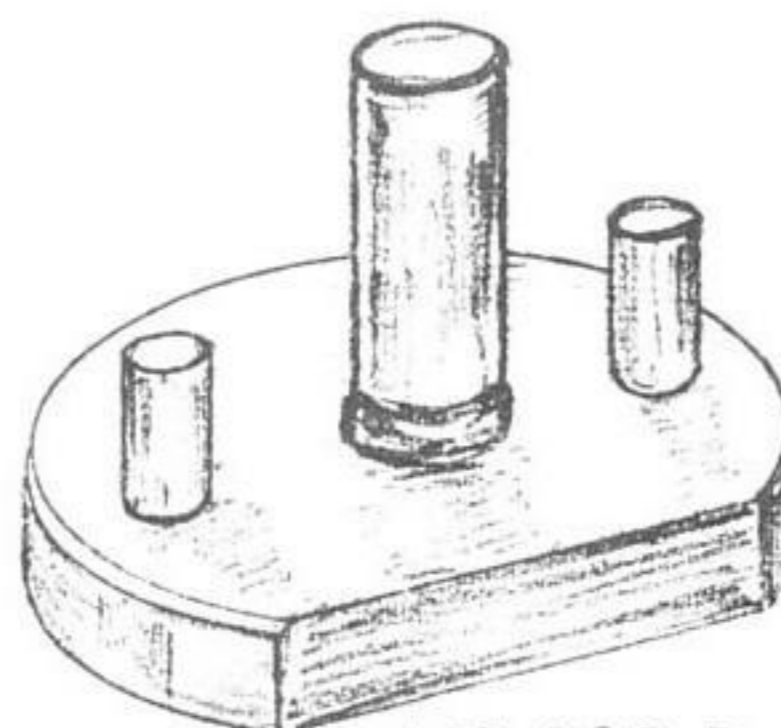

US 328 B

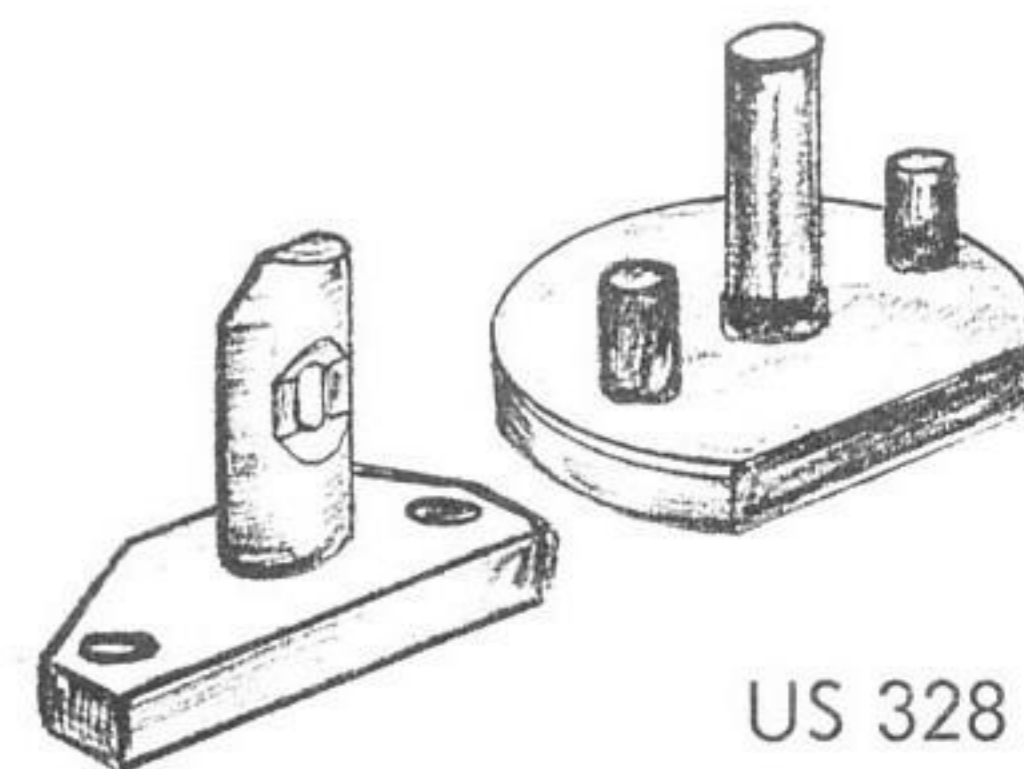

US 328 A &
US 328 B

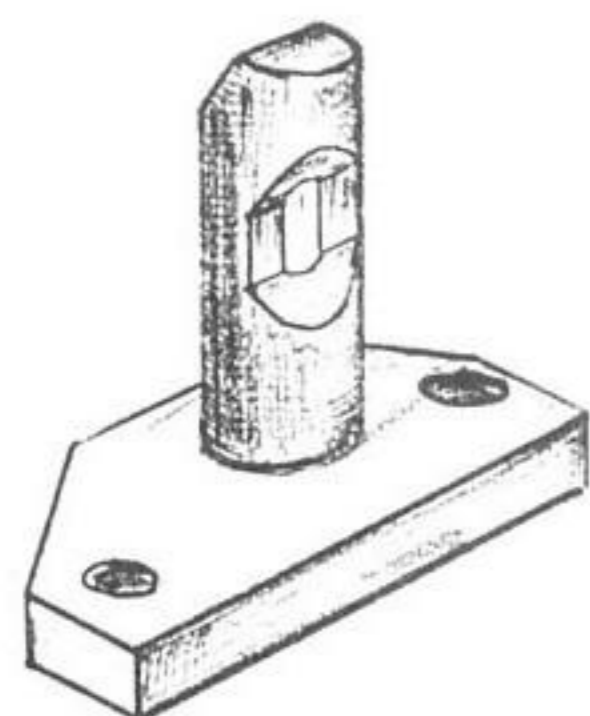

US 328 C

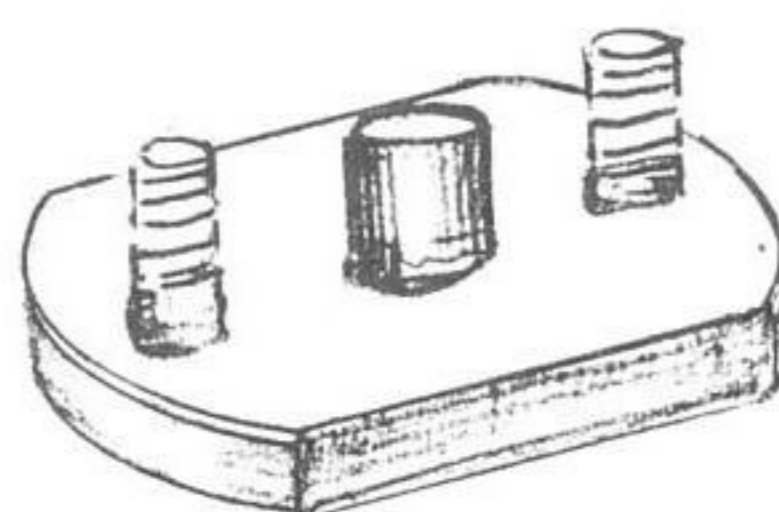

US 328 D

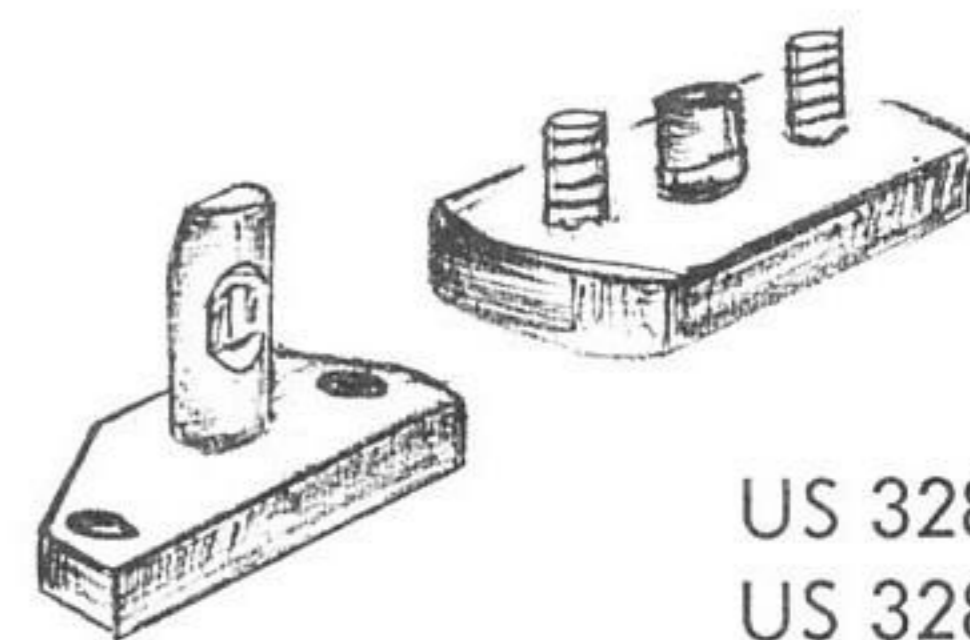

US 328 C &
US 328 D

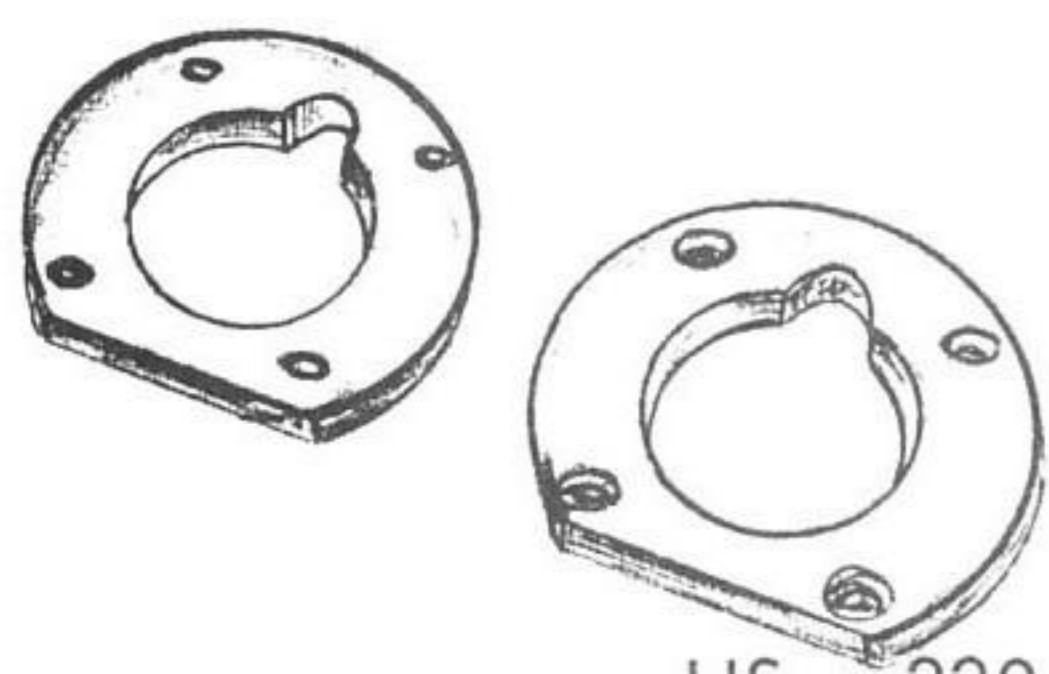

US 330

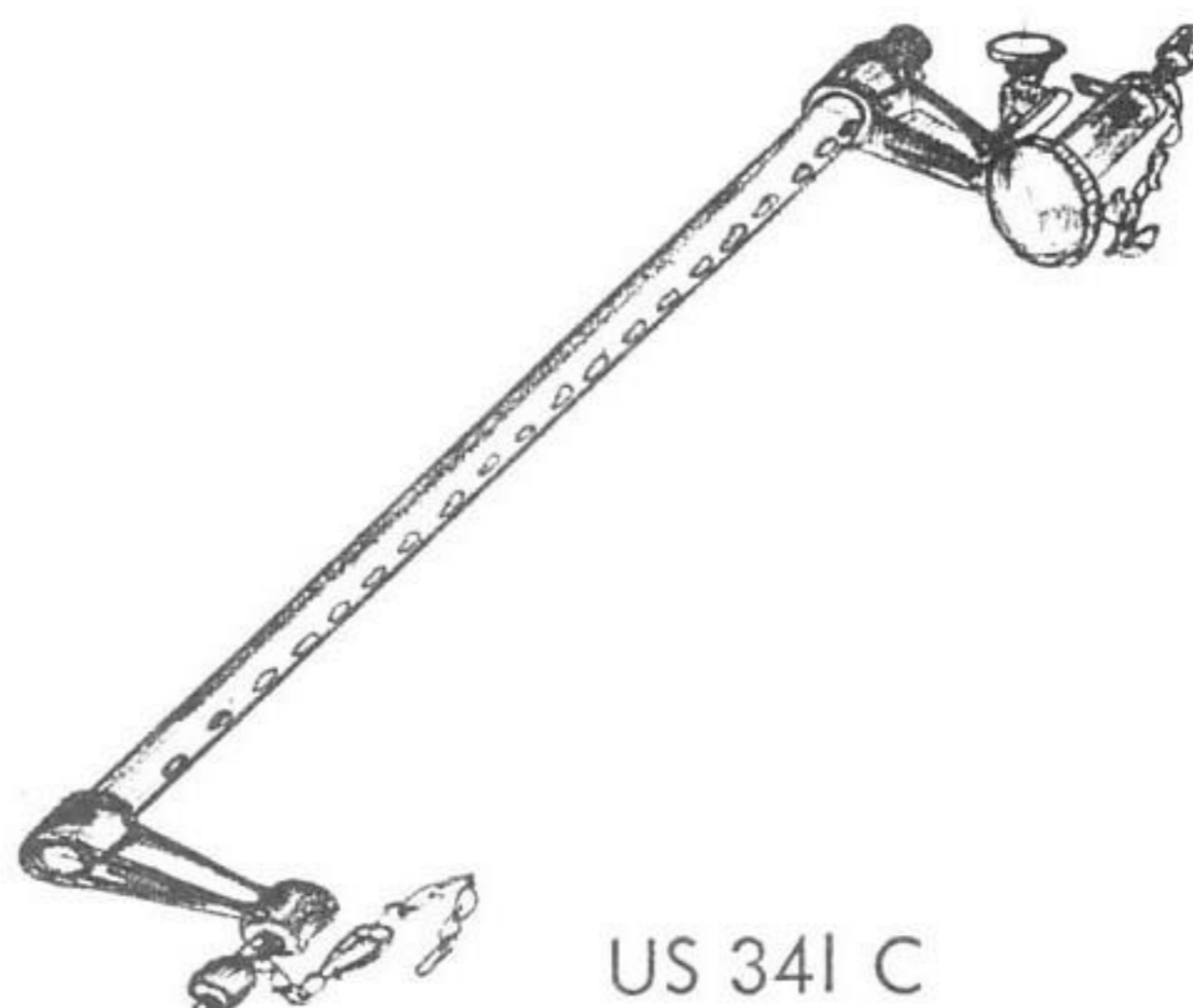

US 341 C

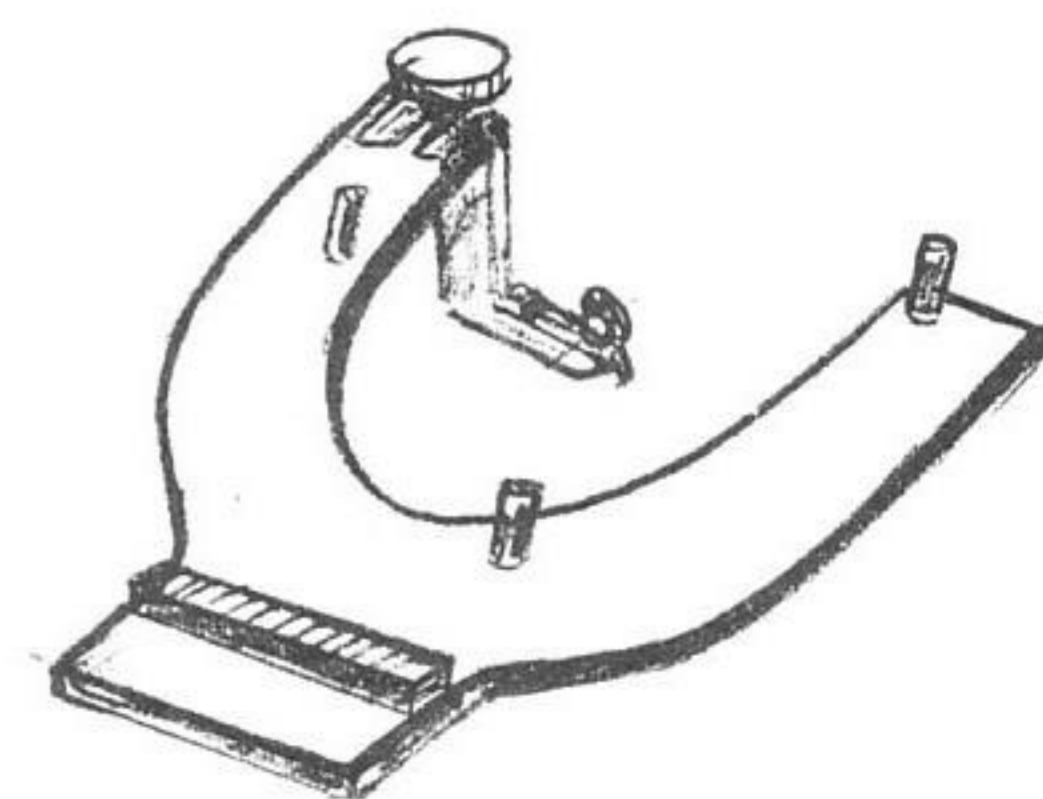

US 350

Special TOOLS

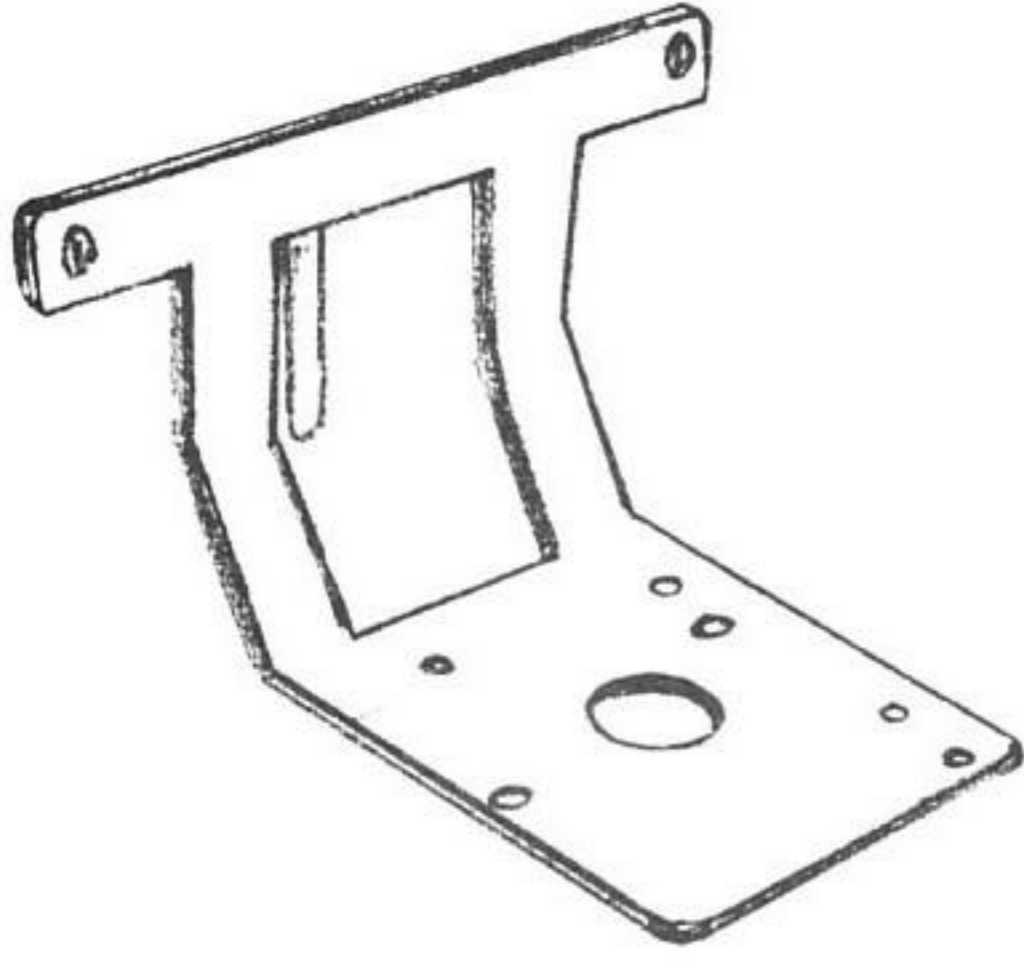

US 351

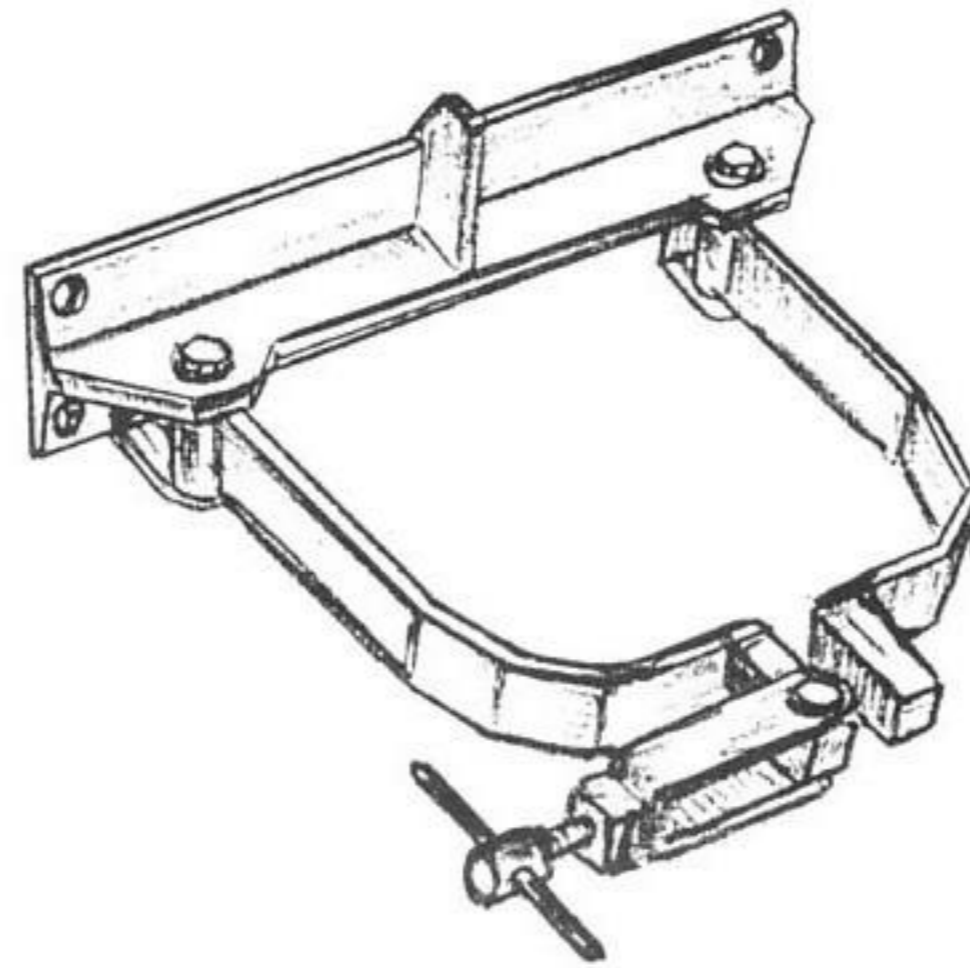

US 352

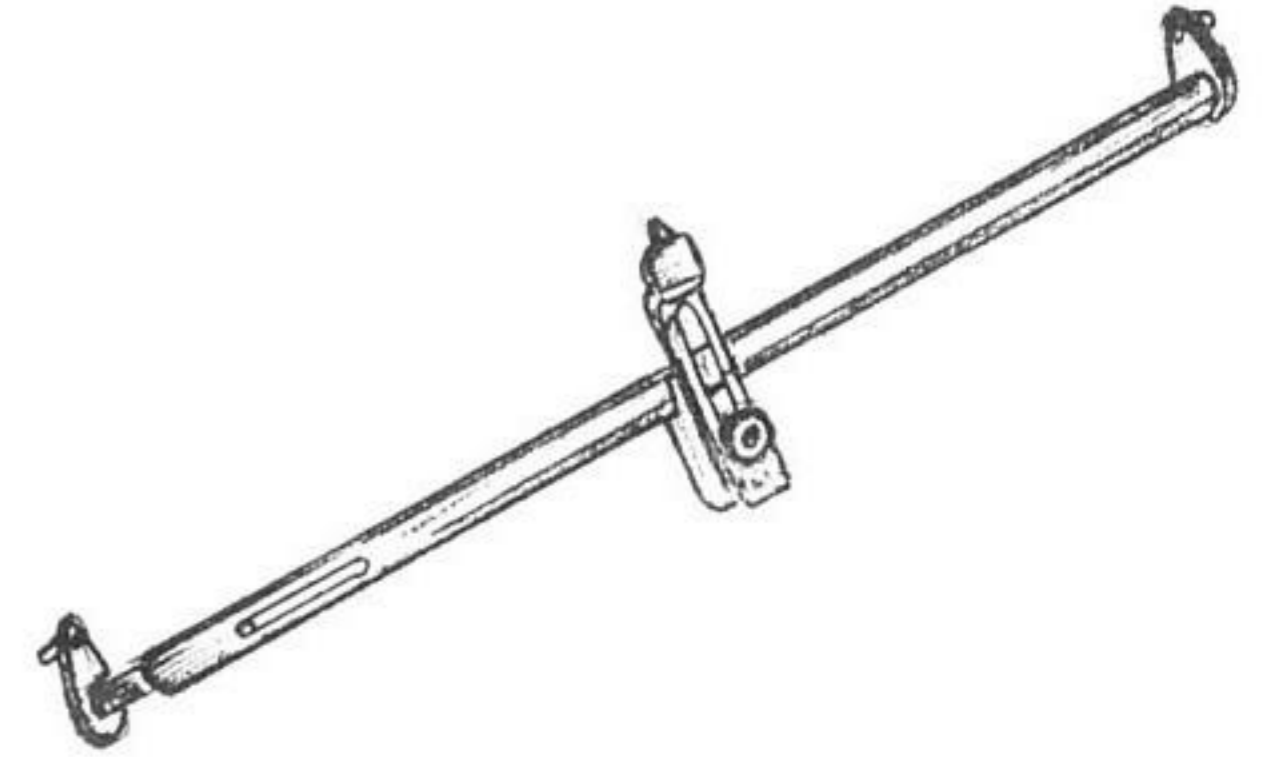

US 360

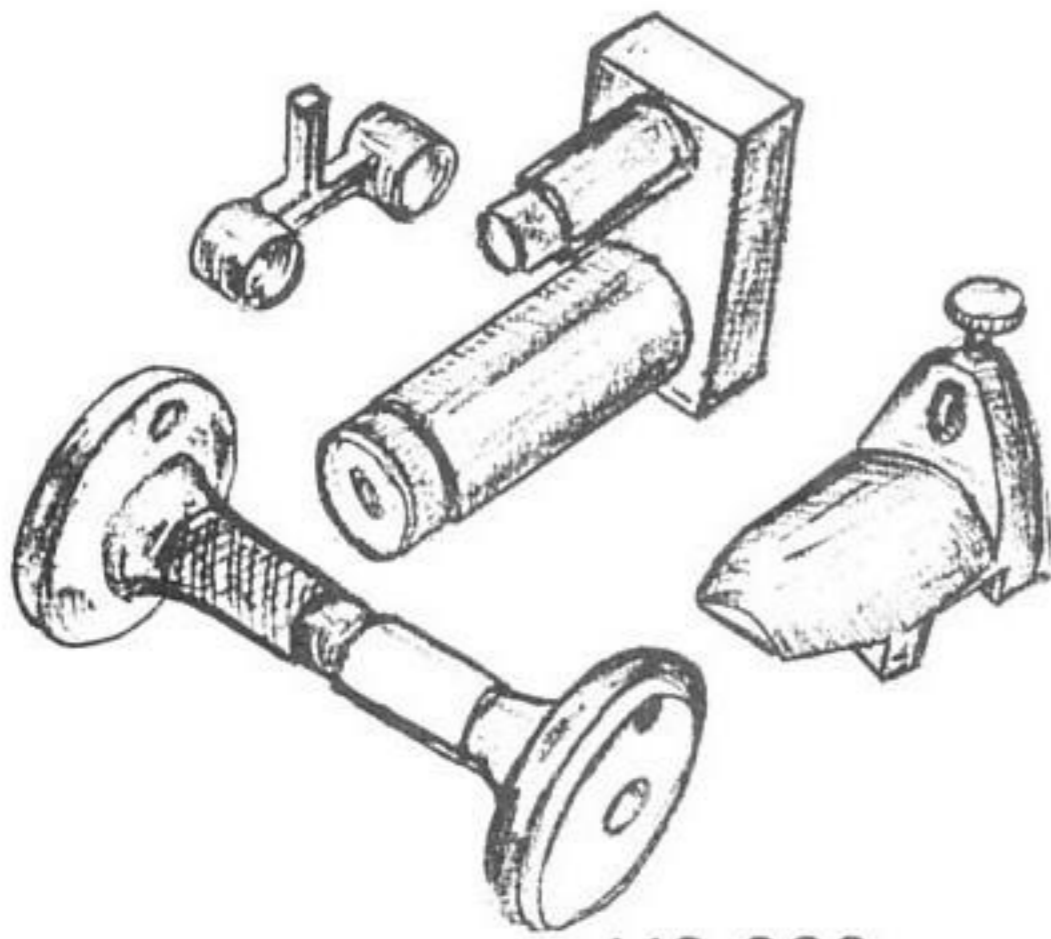

US 380

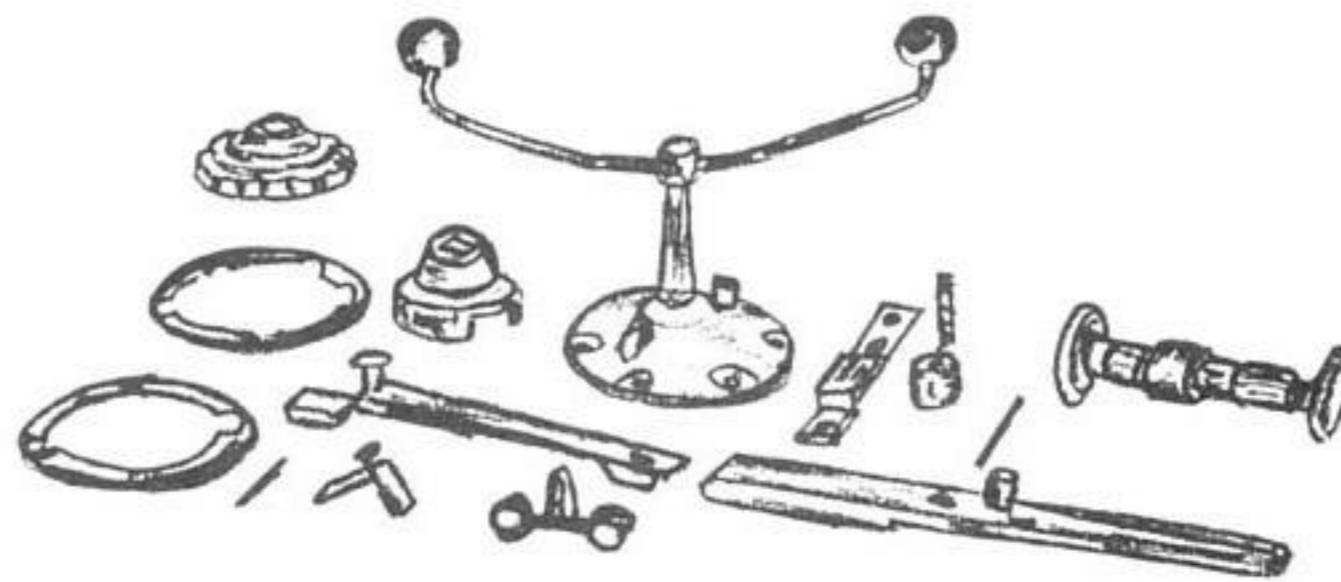

US 381

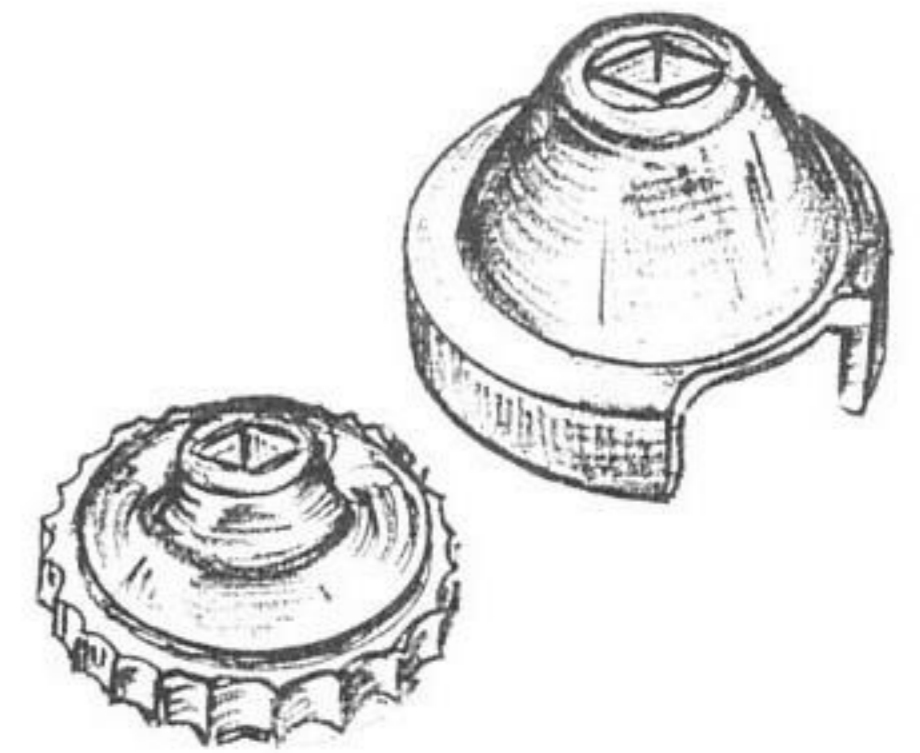

US 381/50

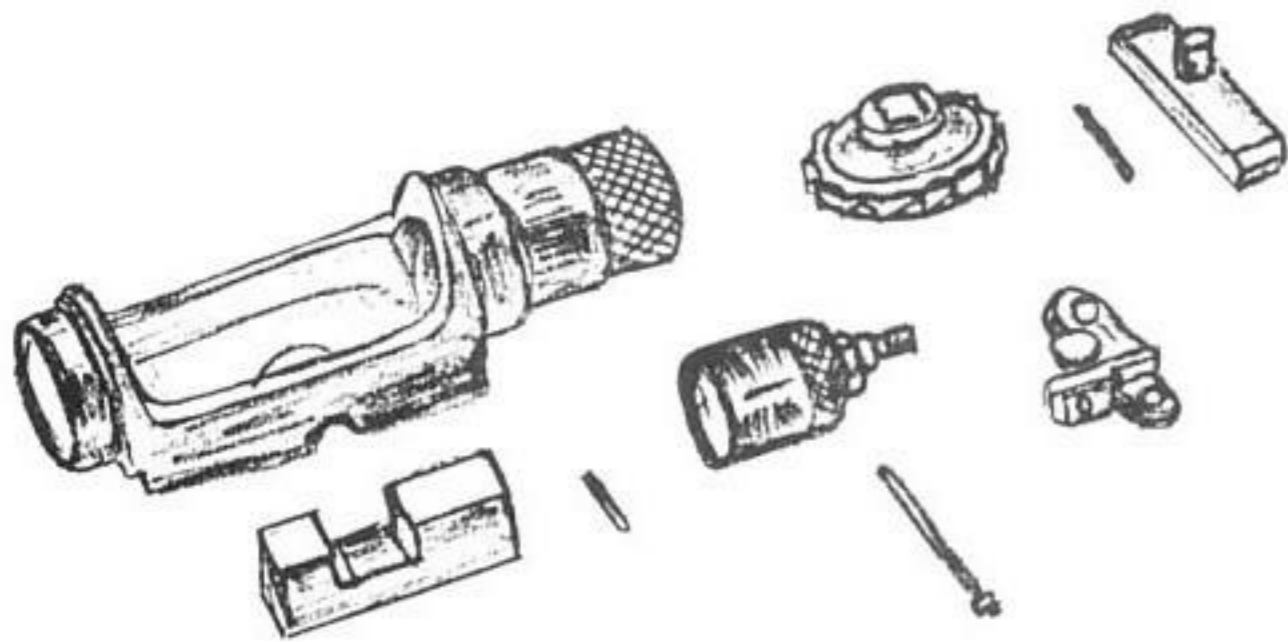

US 382

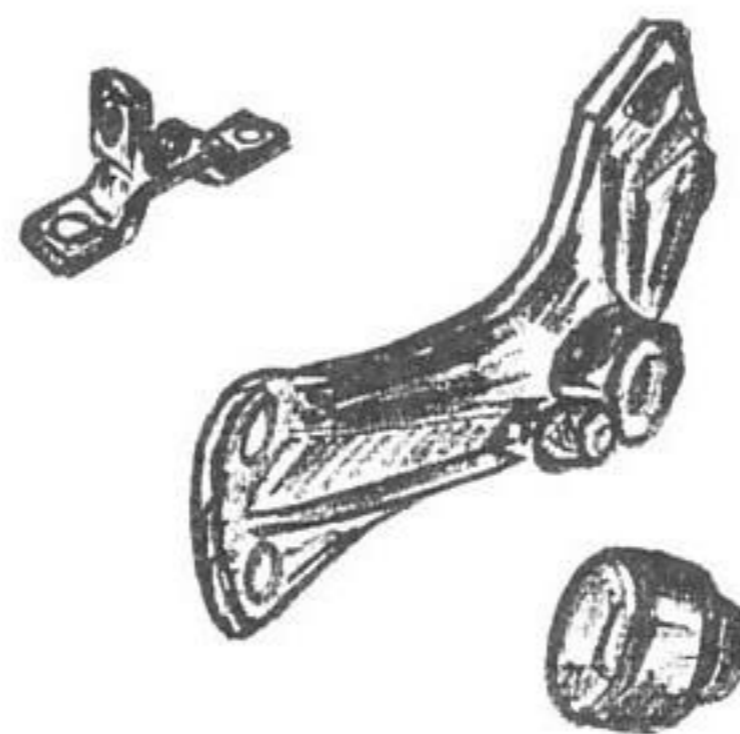

US 384

Special **TOOLS**

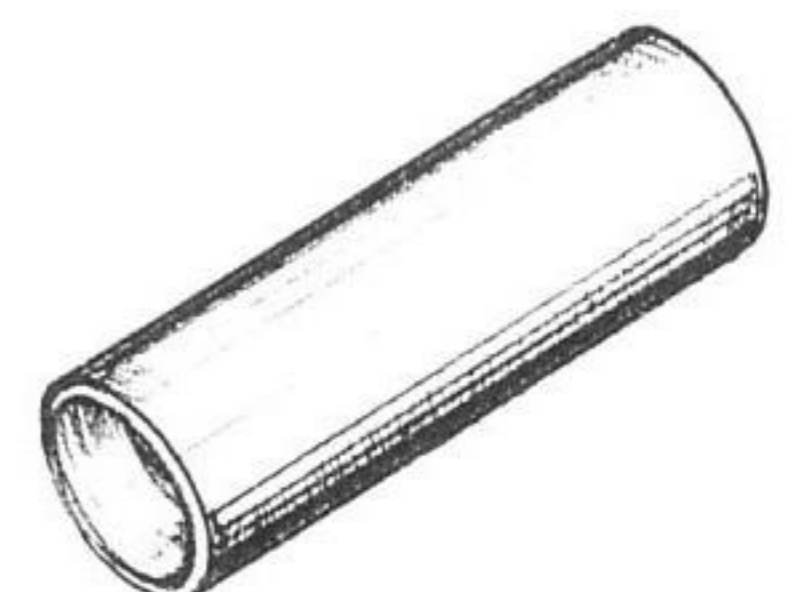
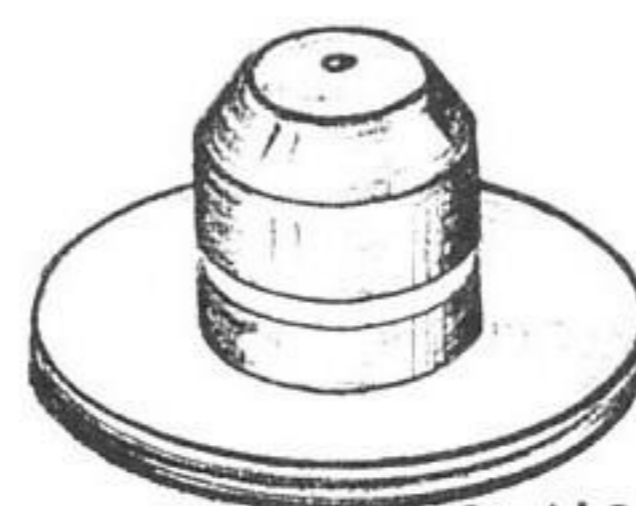
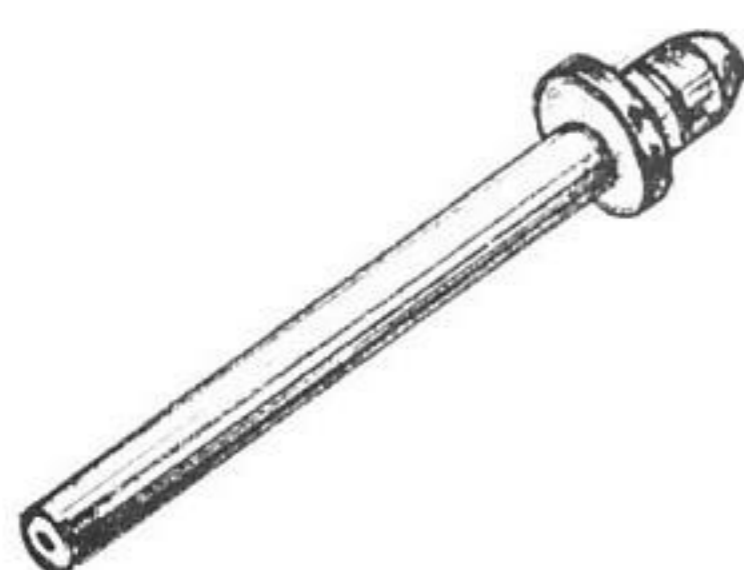
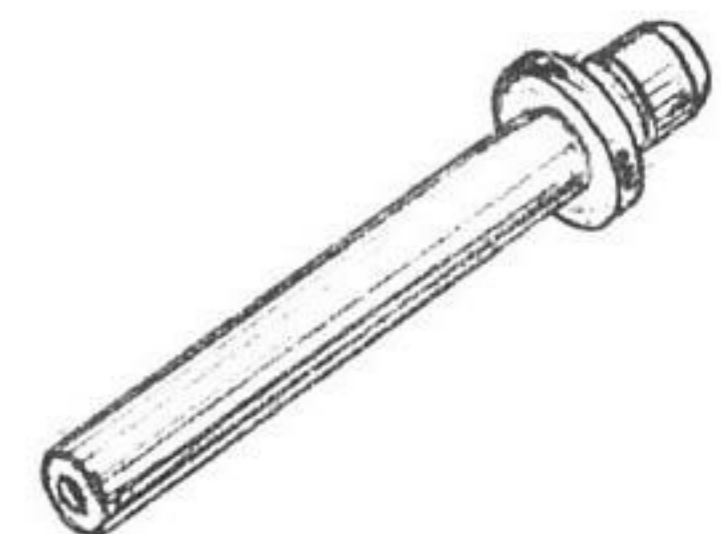
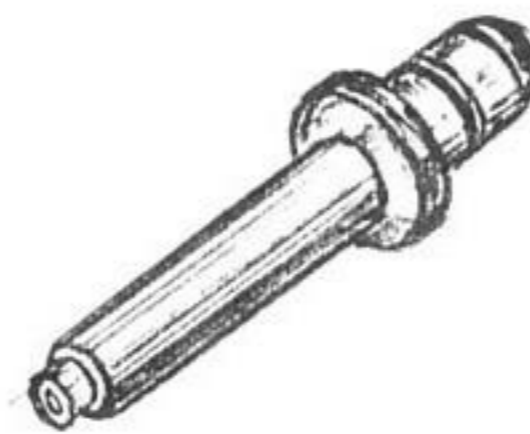
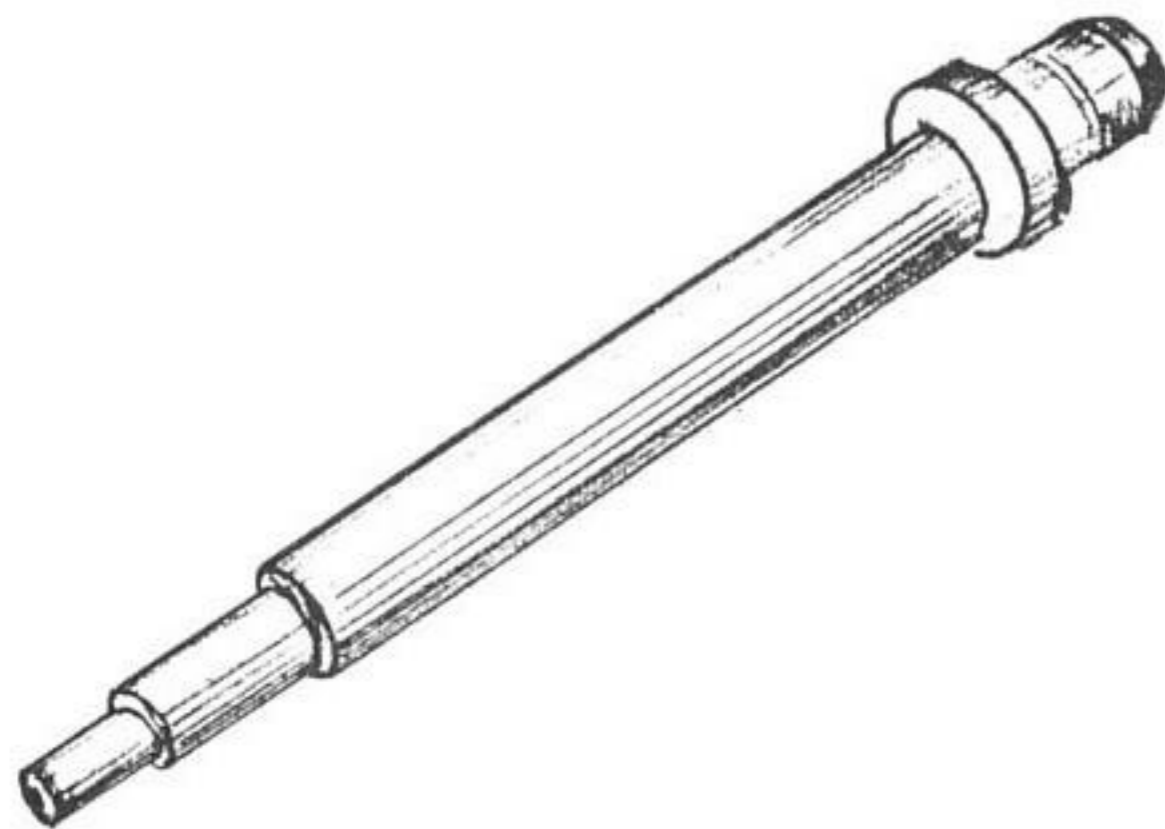
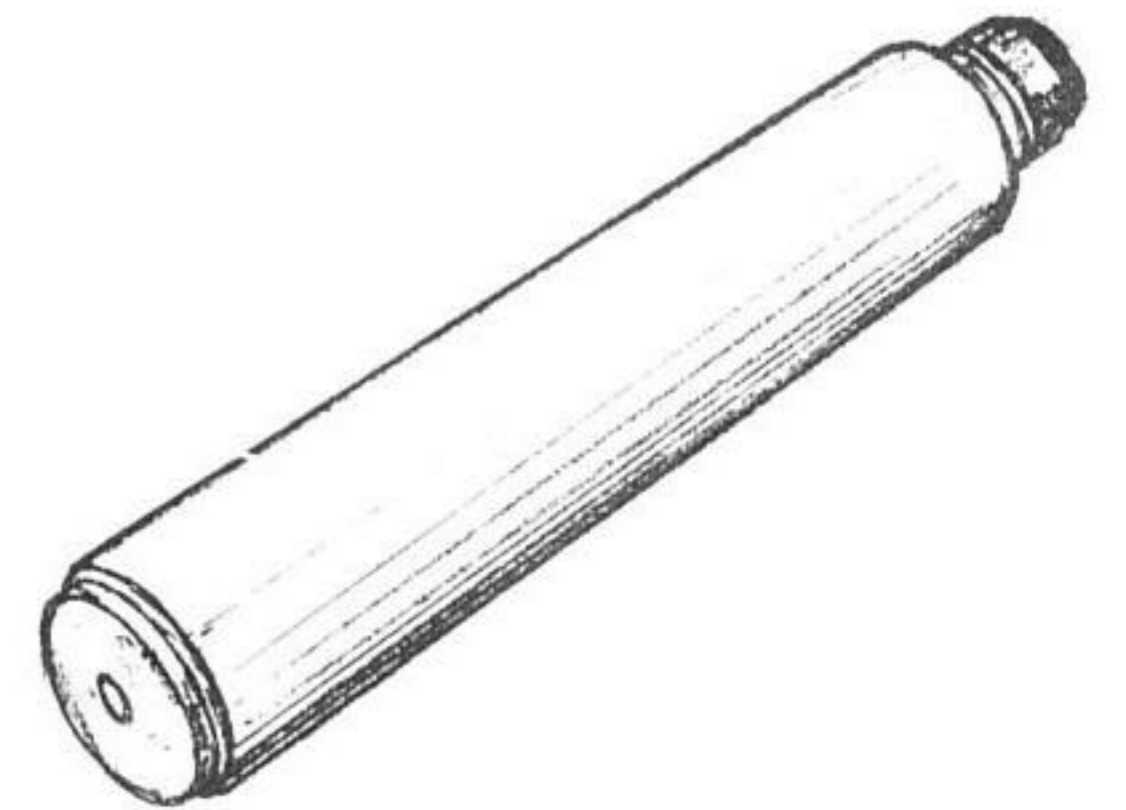
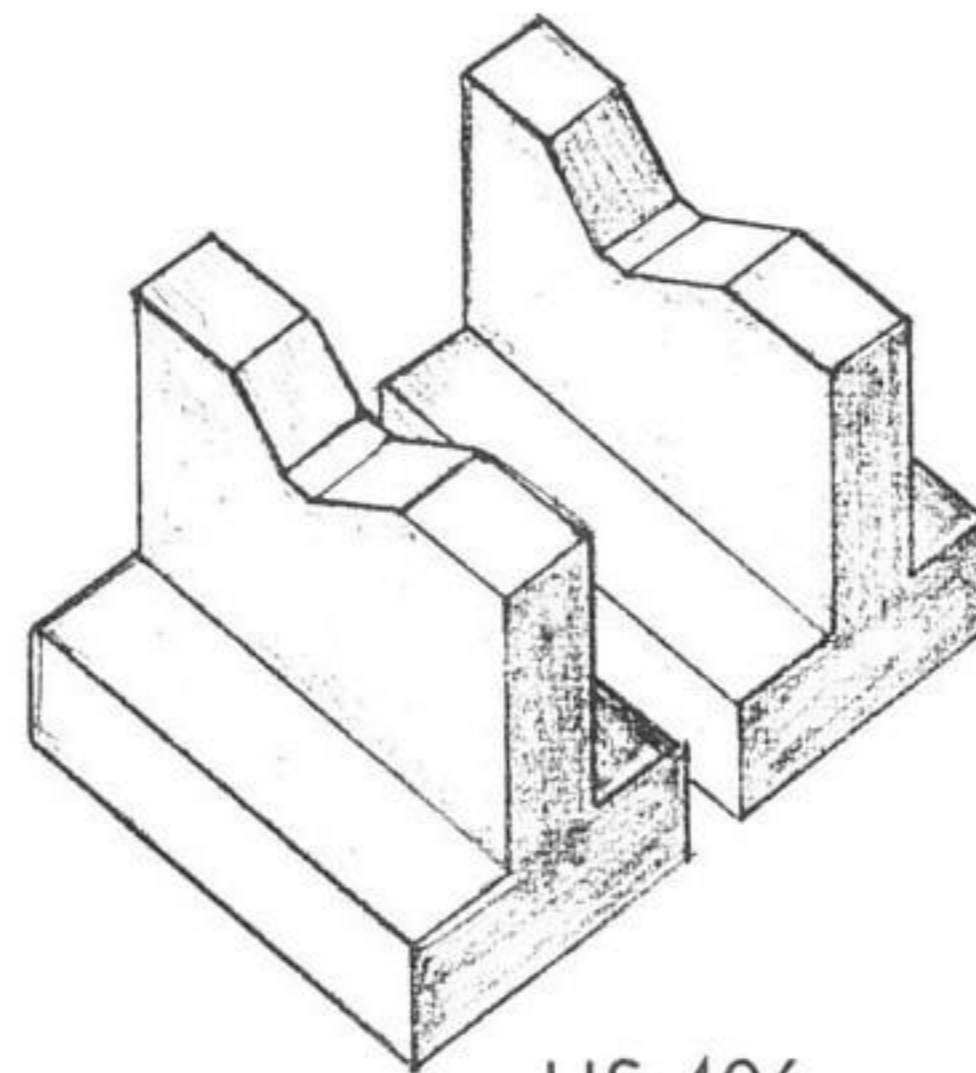
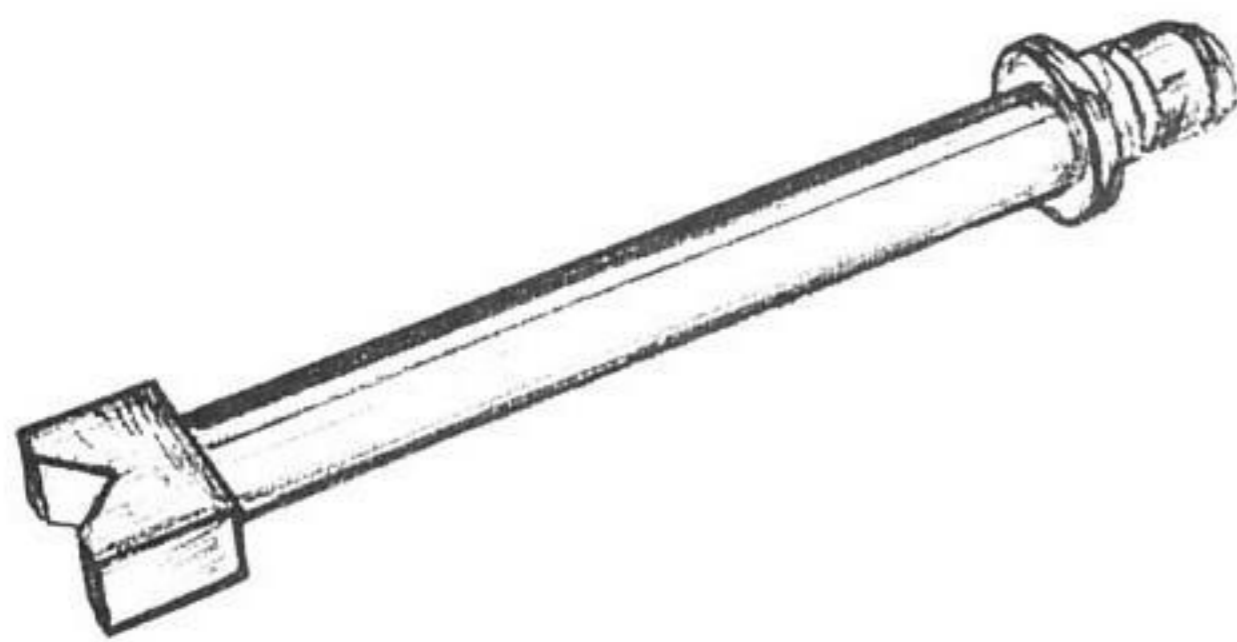
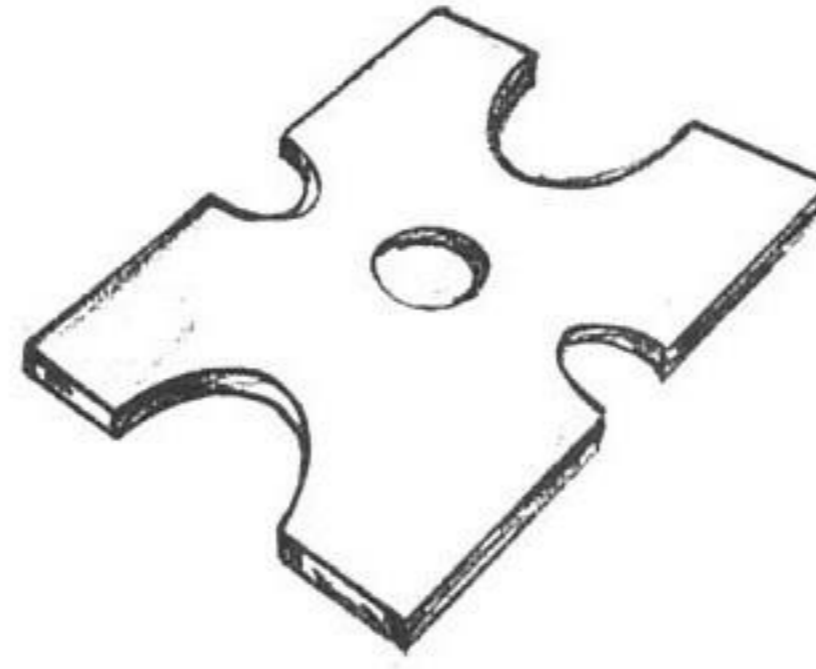
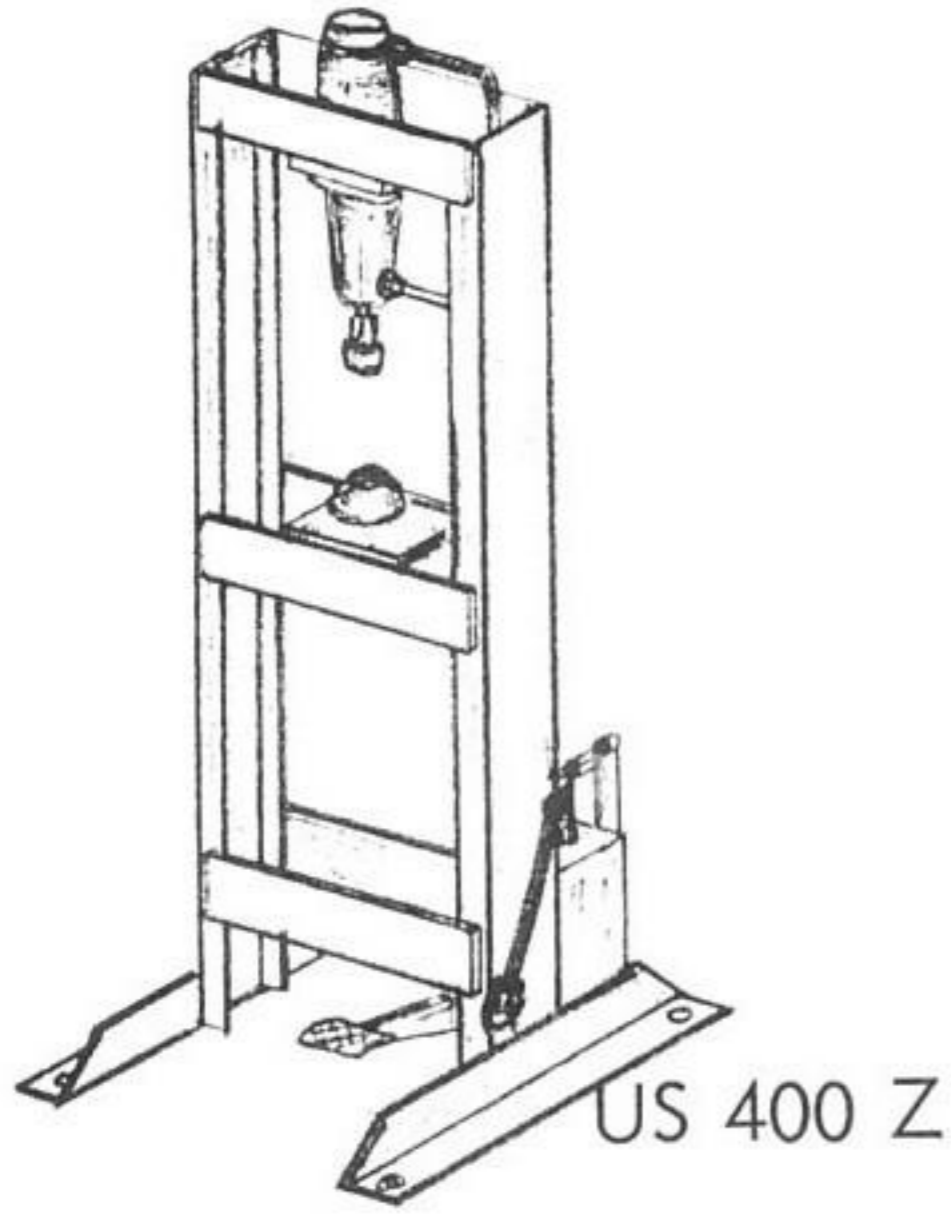

Special **TOOLS**

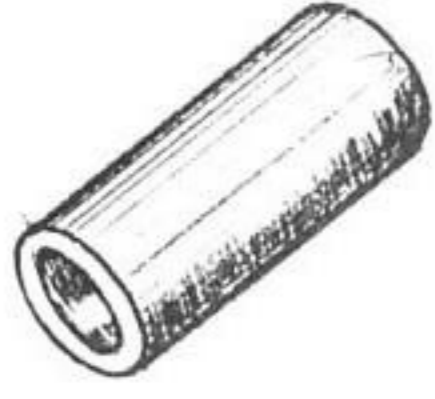

US 416 B



US 417

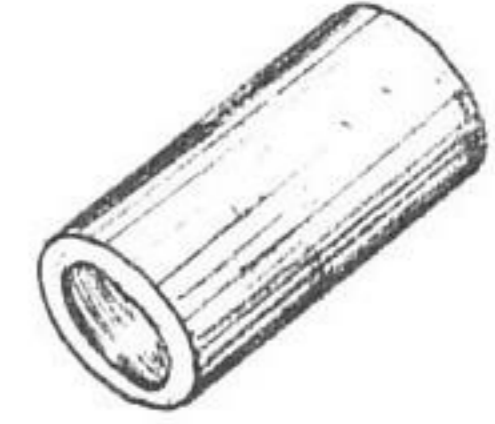

US 418 A



US 419



US 420

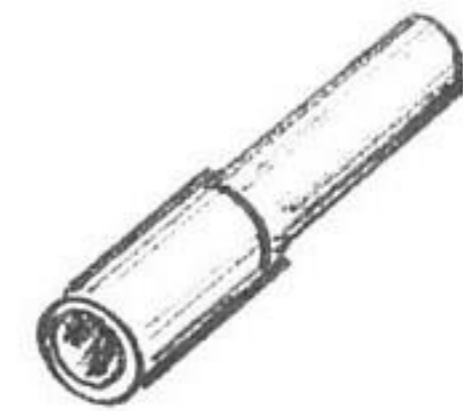

US 421



US 422



US 423

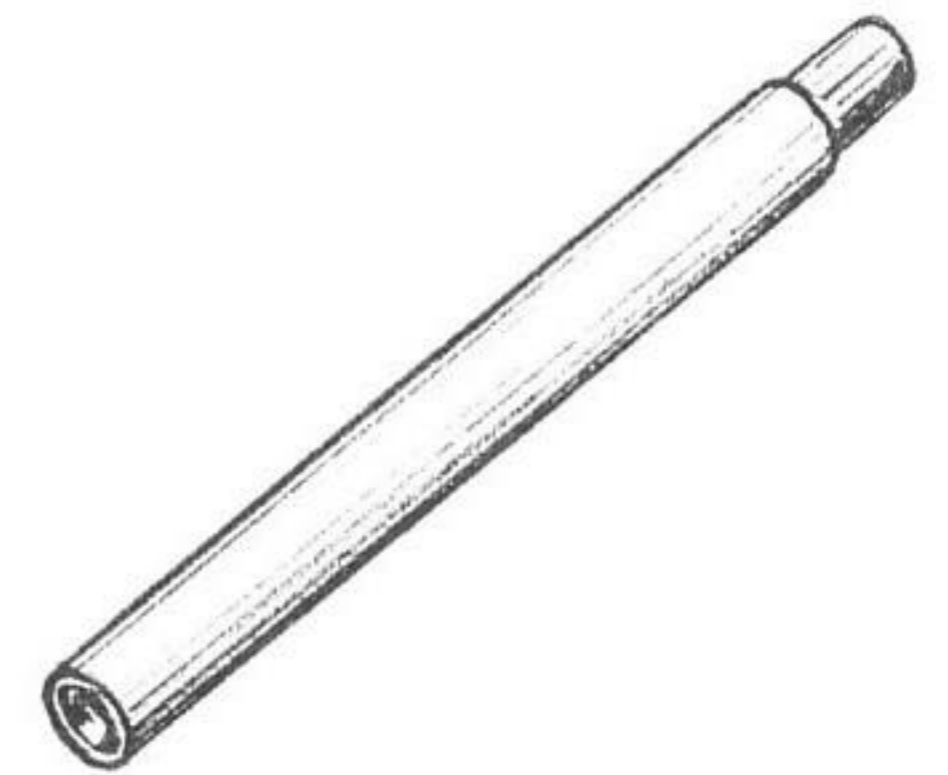

US 424

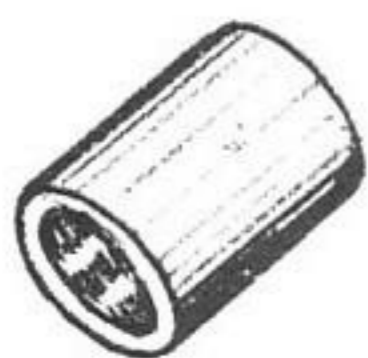

US 426



US 427



US 428

Special TOOLS

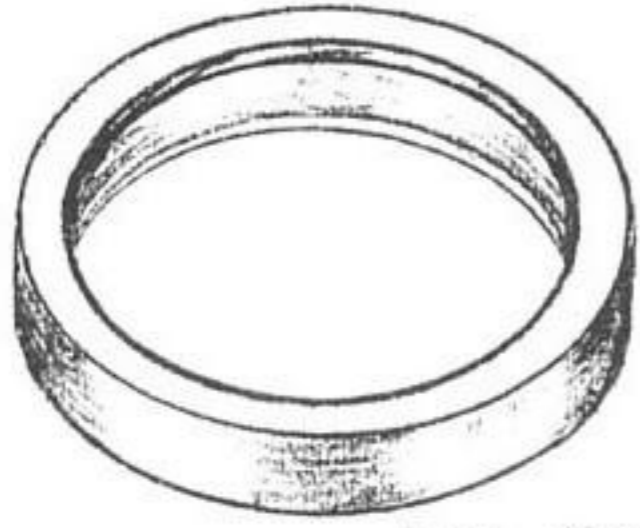

US 429

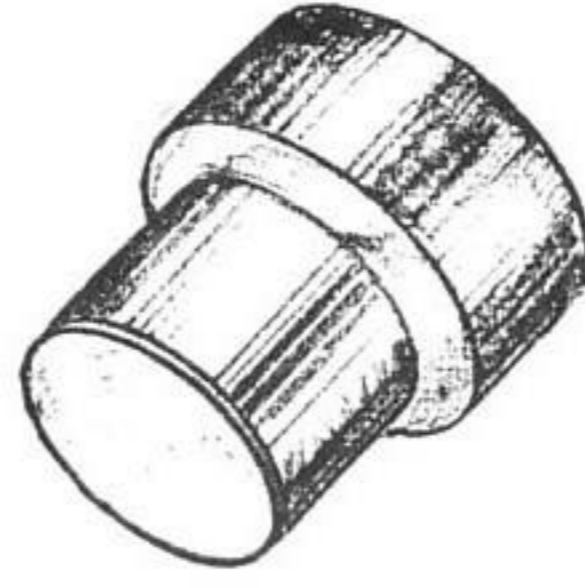

US 430

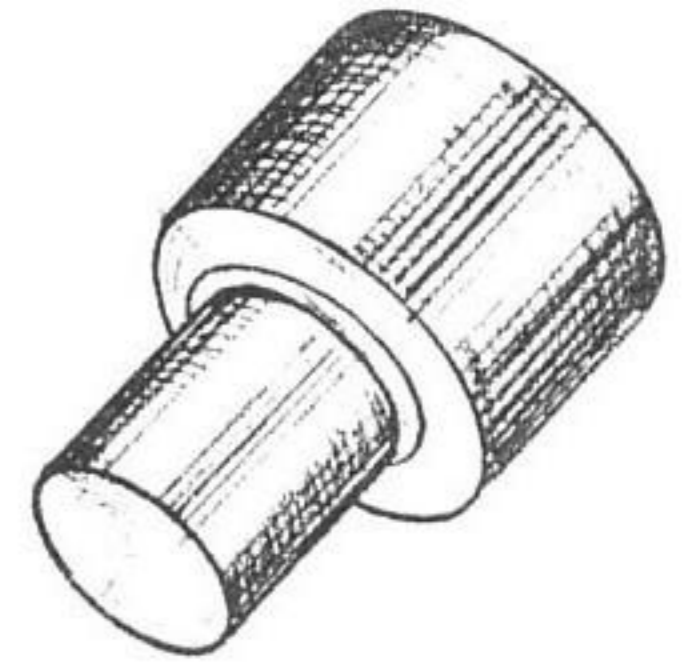

US 431

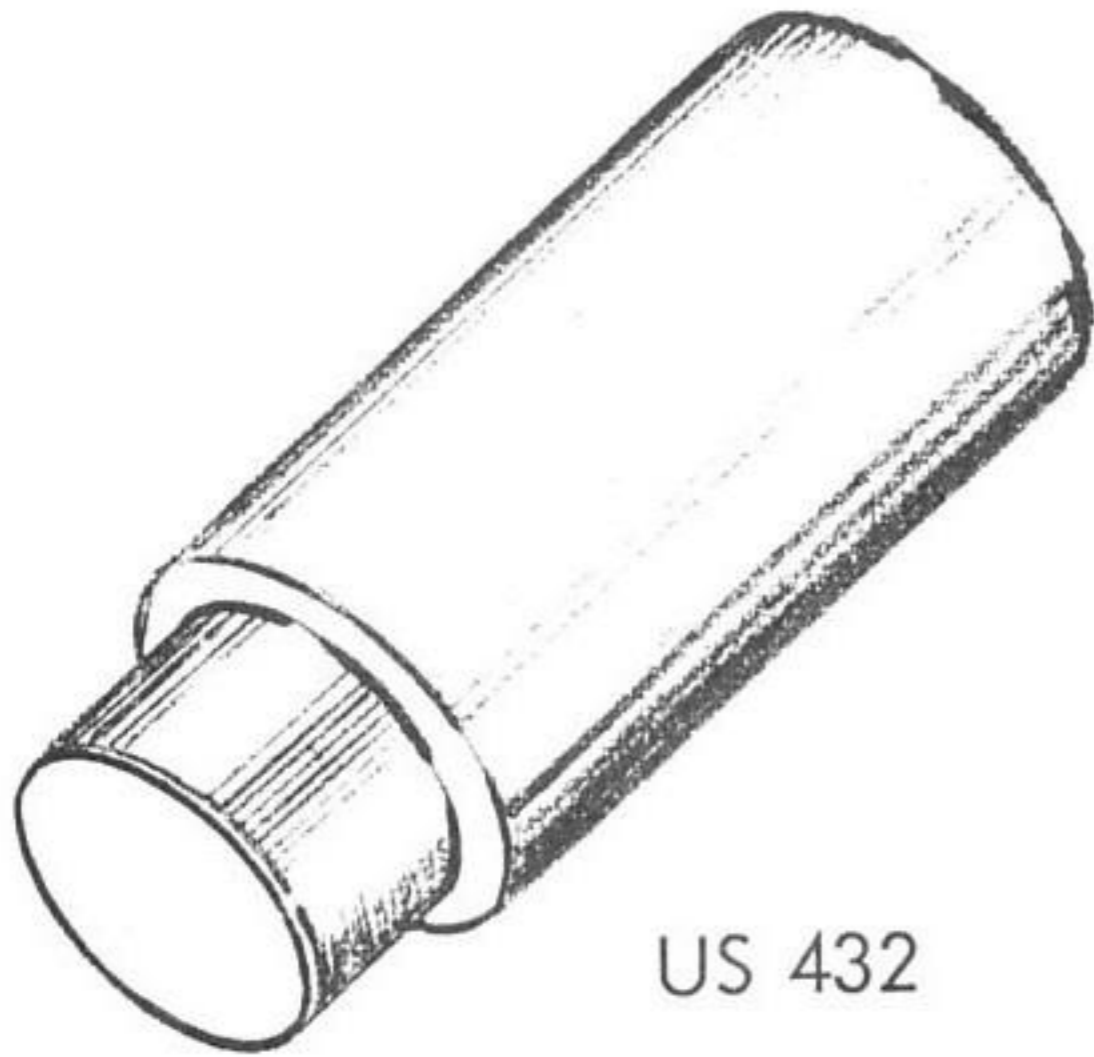

US 432

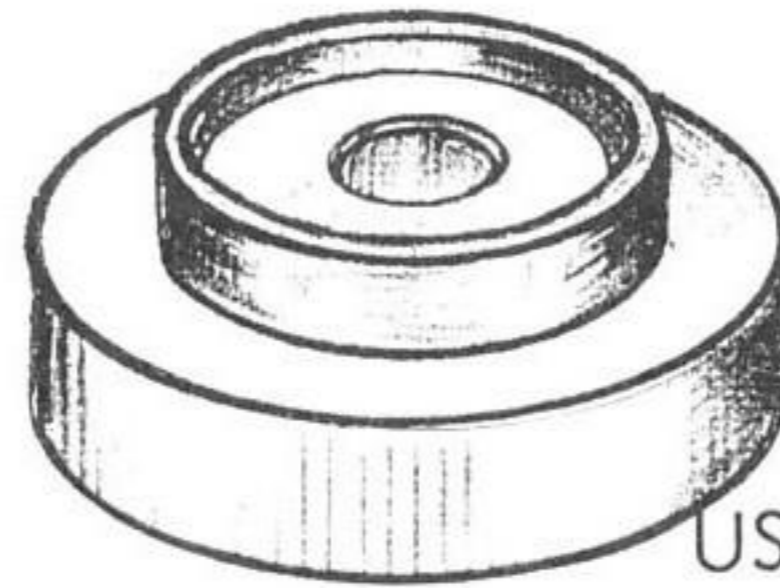

US 433

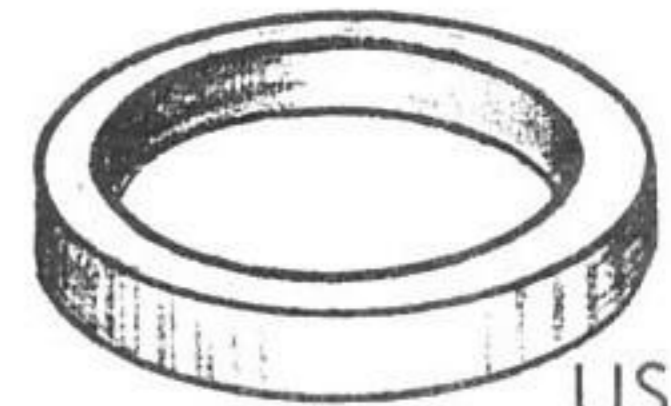

US 433 A

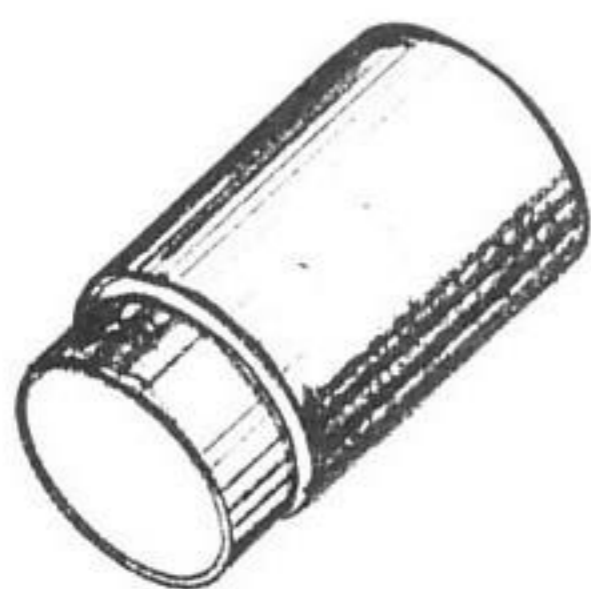

US 434

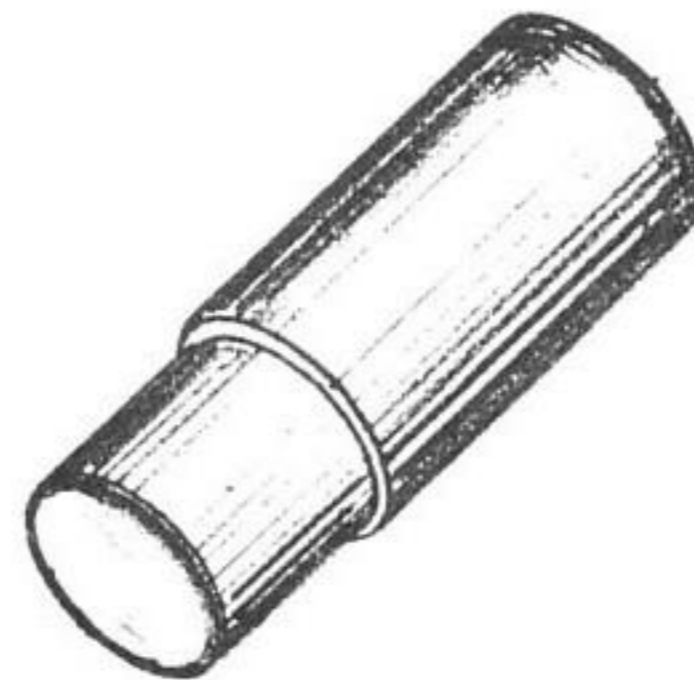

US 435

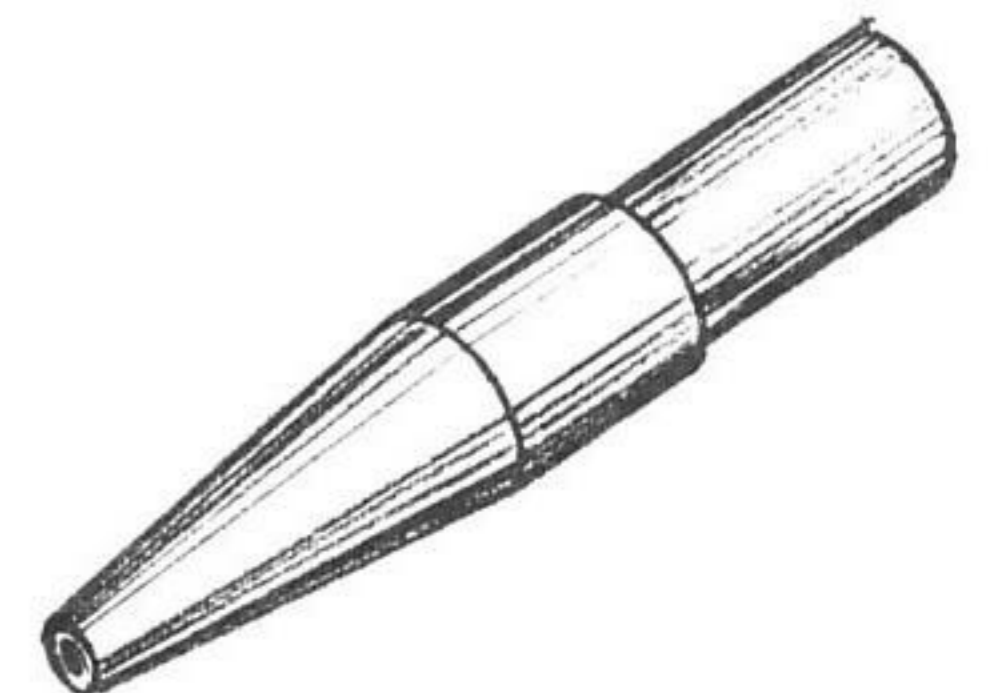

US 436 A

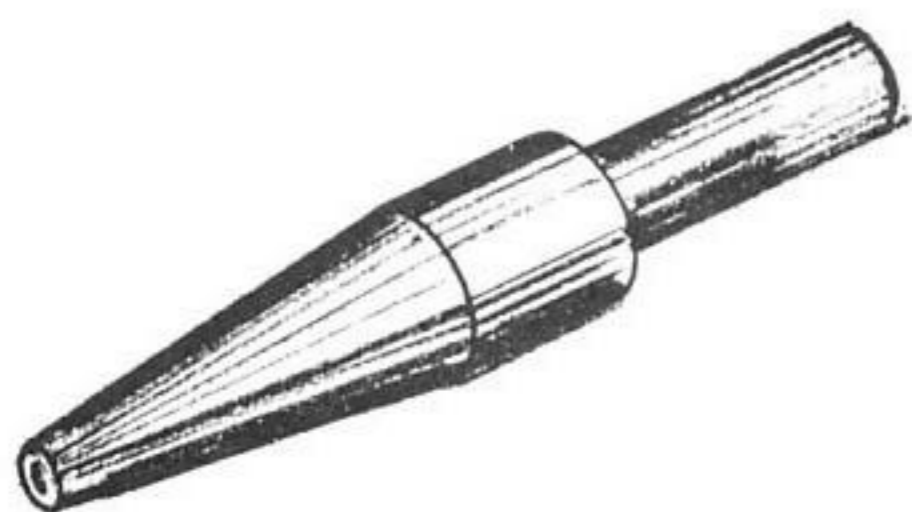

US 437 A

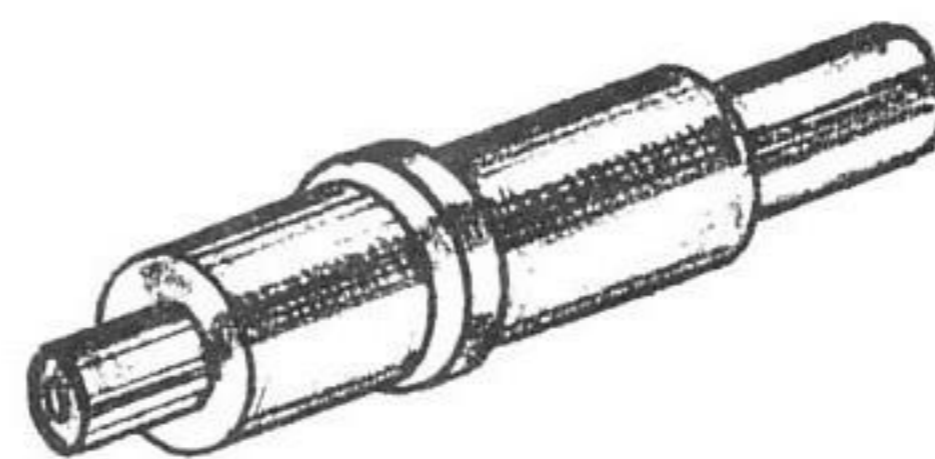

US 438

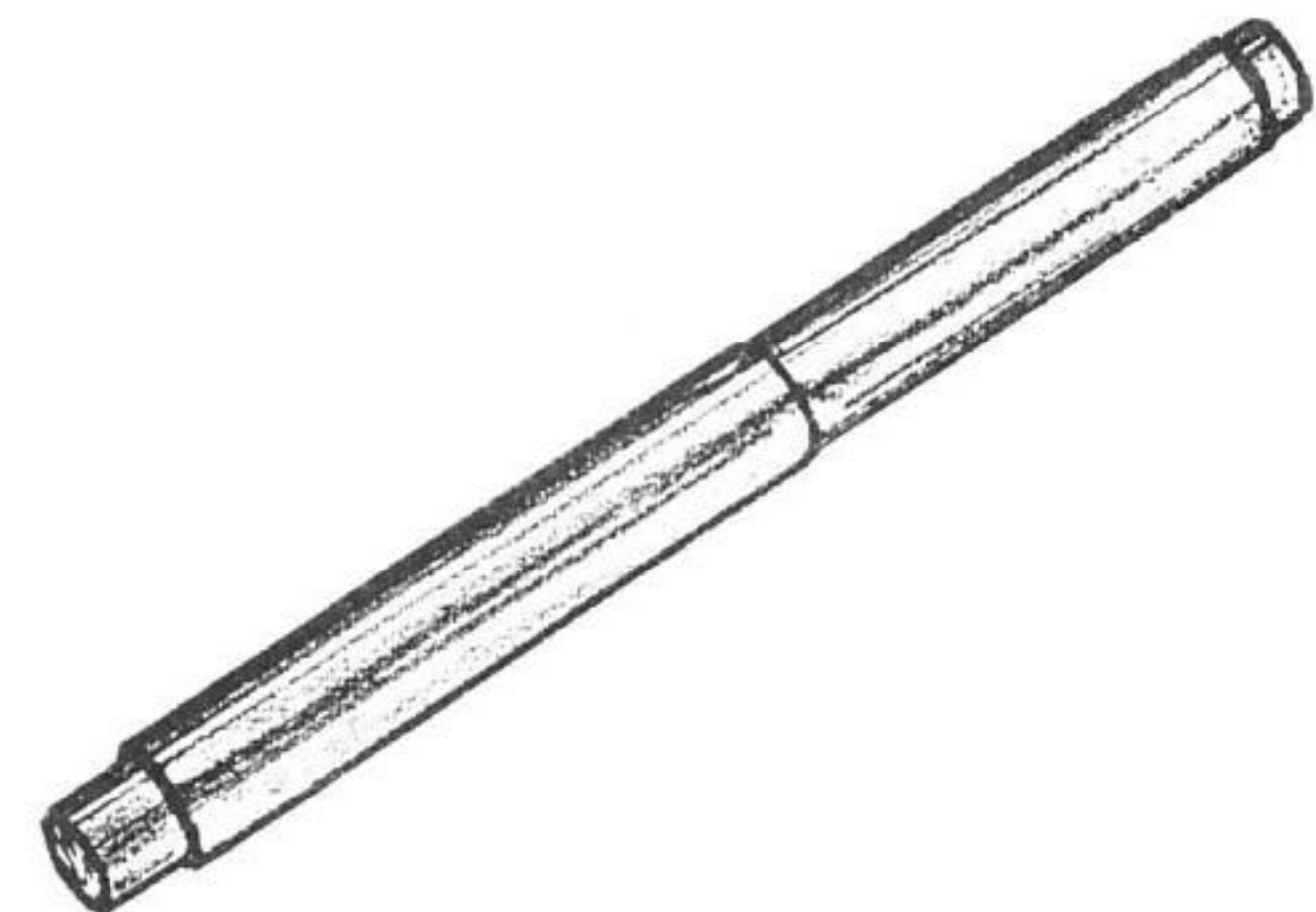

US 439

Special TOOLS

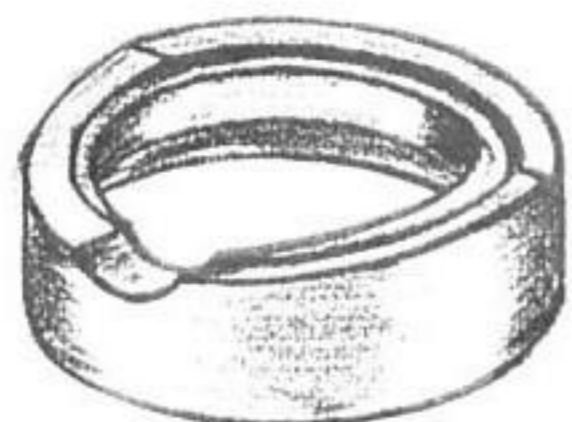

US 440

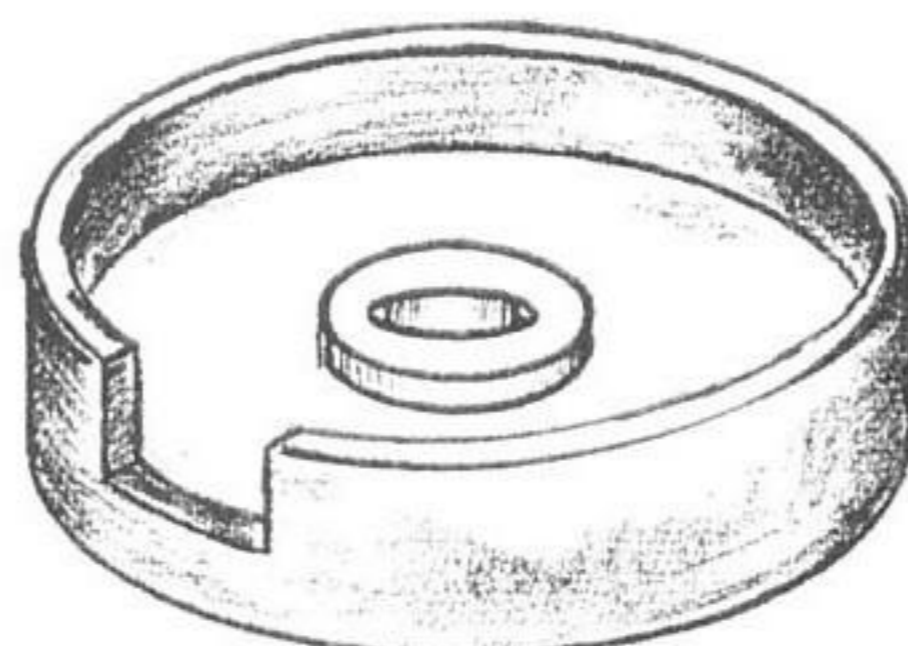

US 441

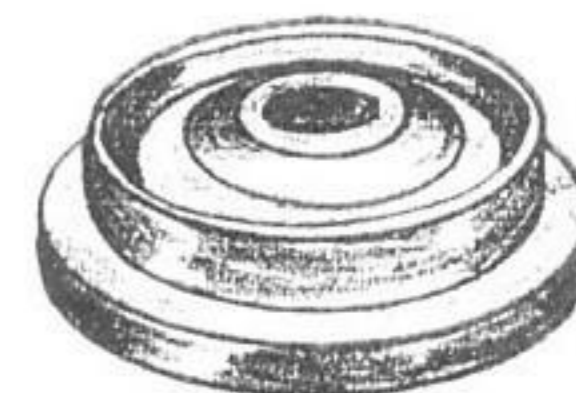

US 442

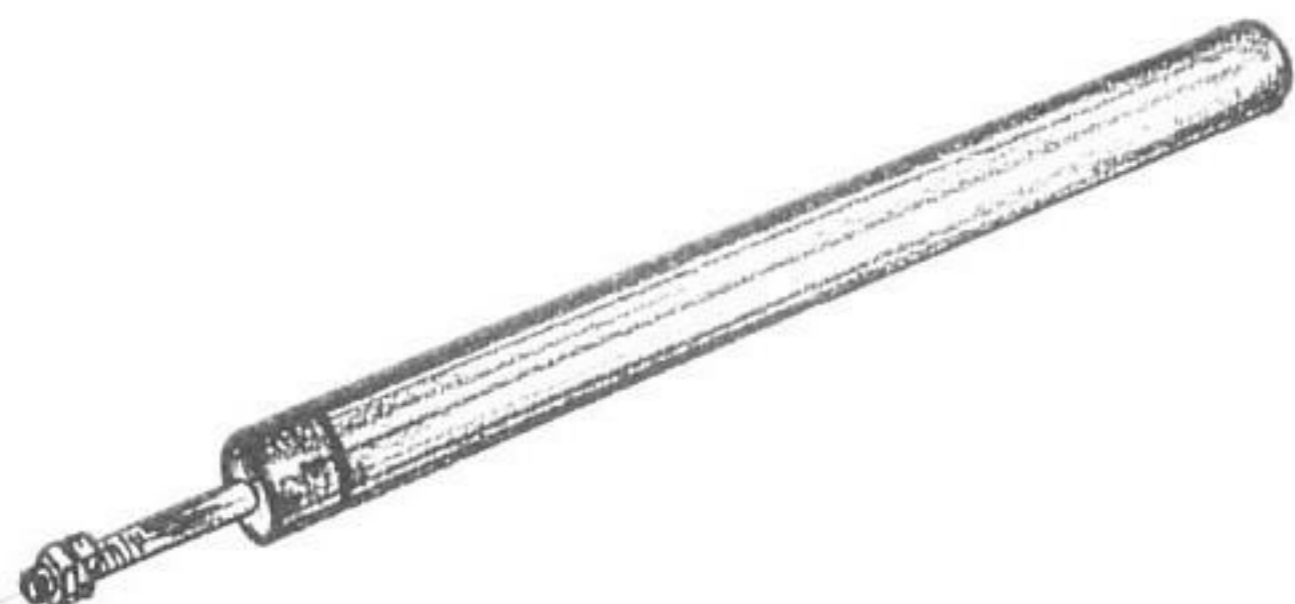

US 446

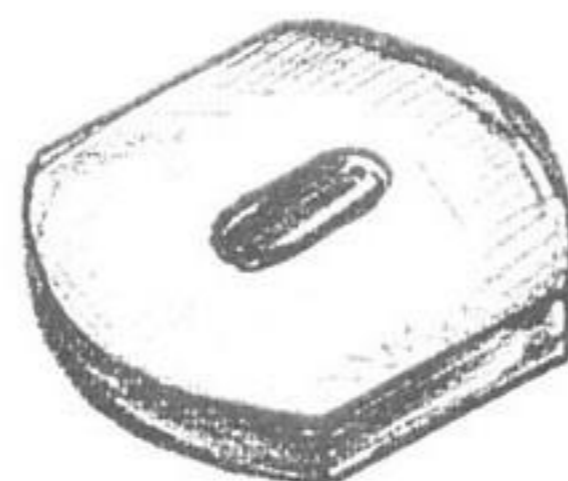

US 447

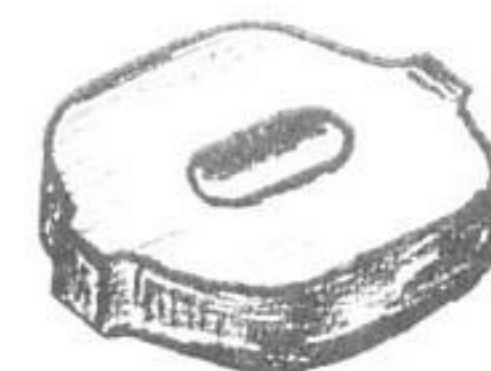

US 447 A

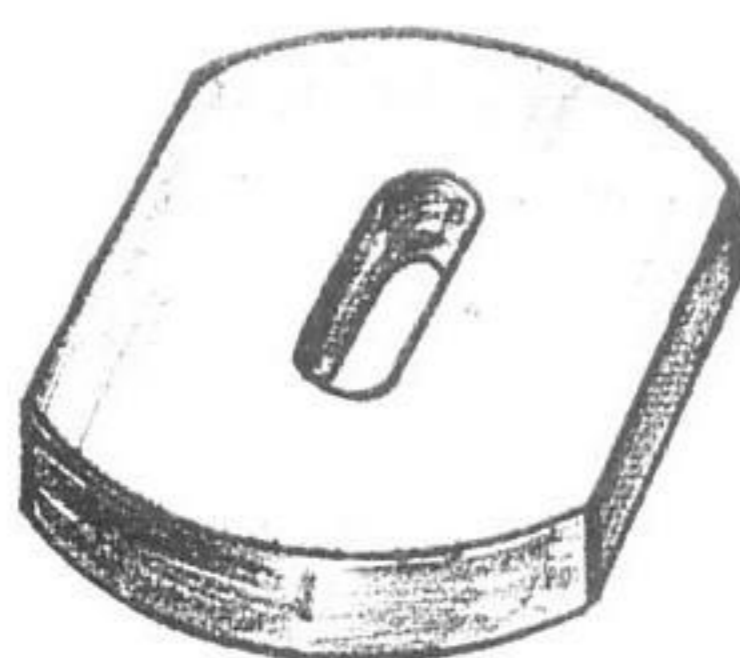

US 447 B

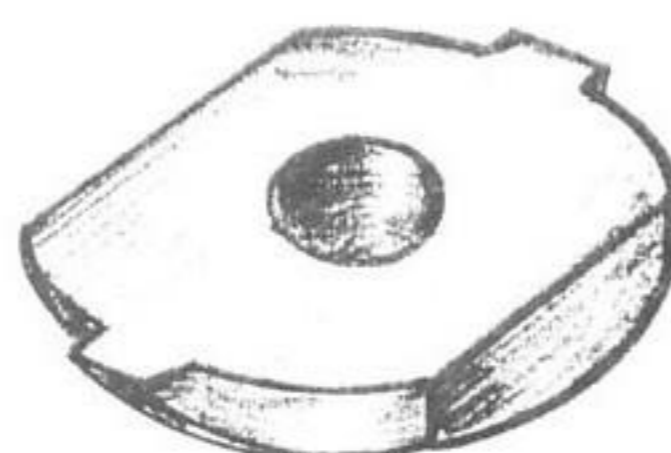

US 447 C

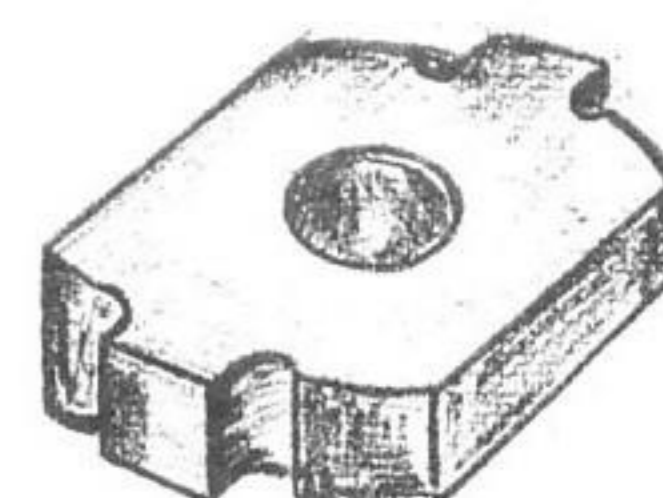

US 447 D

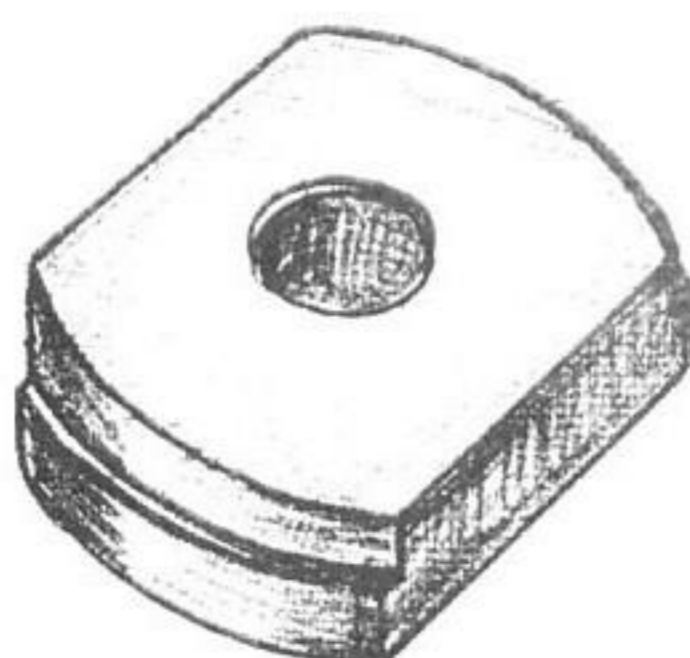

US 447 F

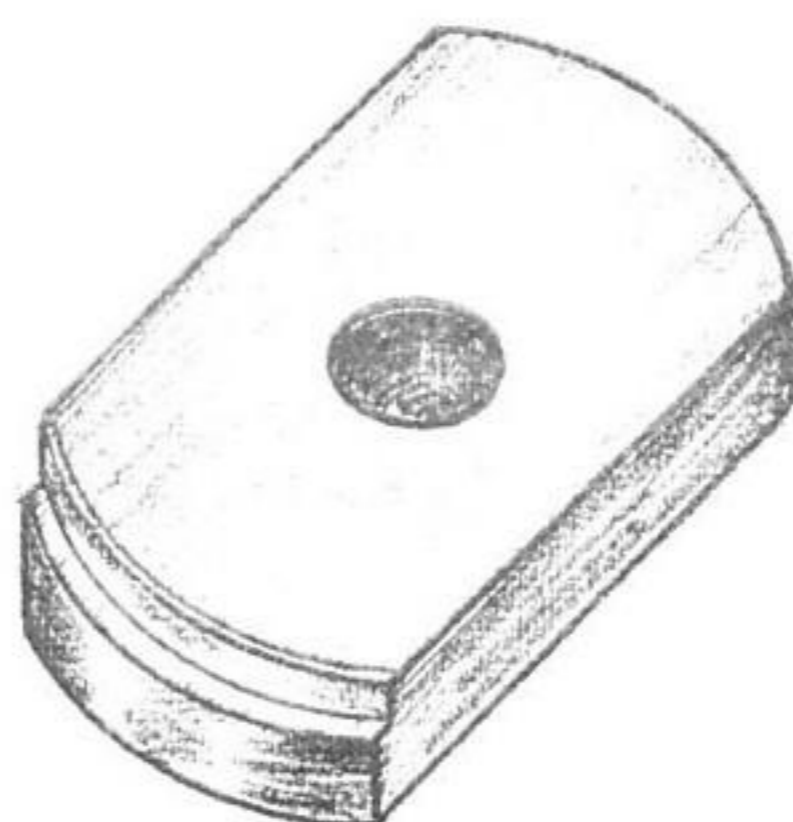

US 447 G

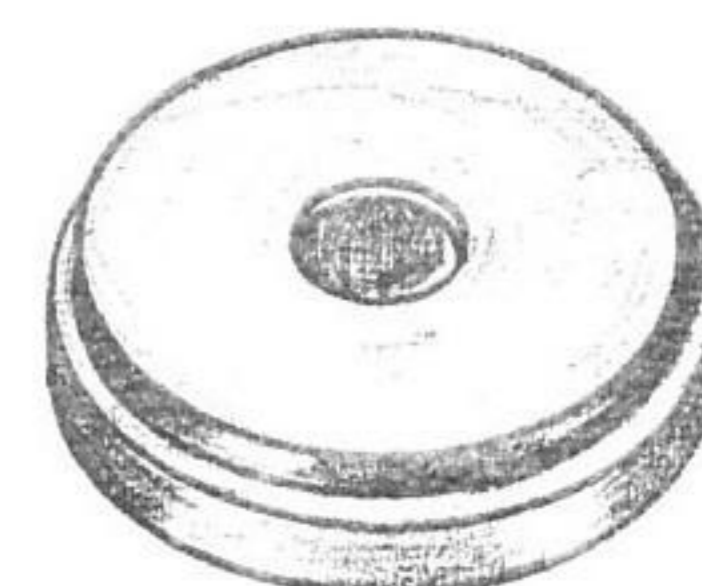

US 447 H

Special TOOLS

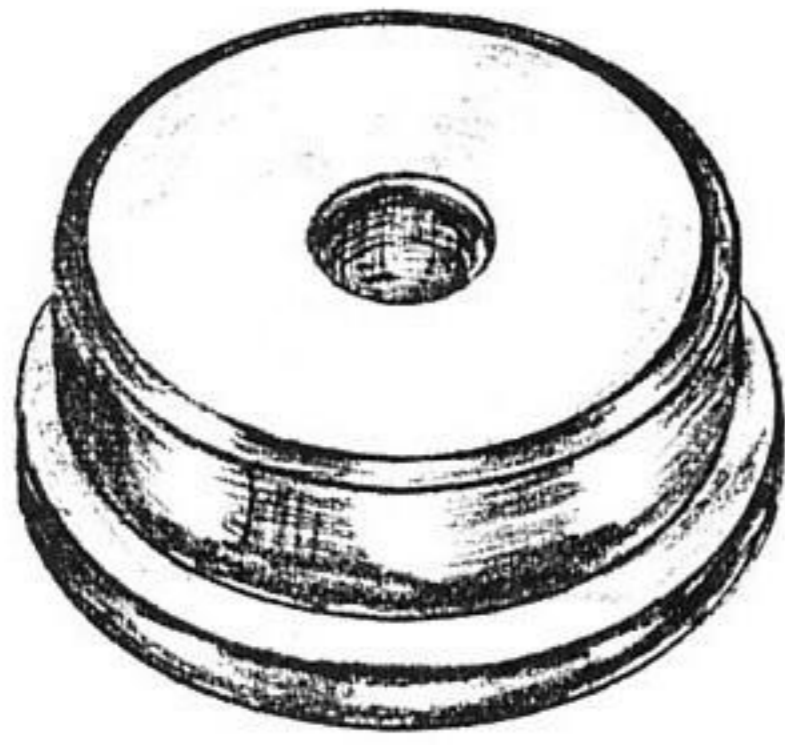

US 447 I

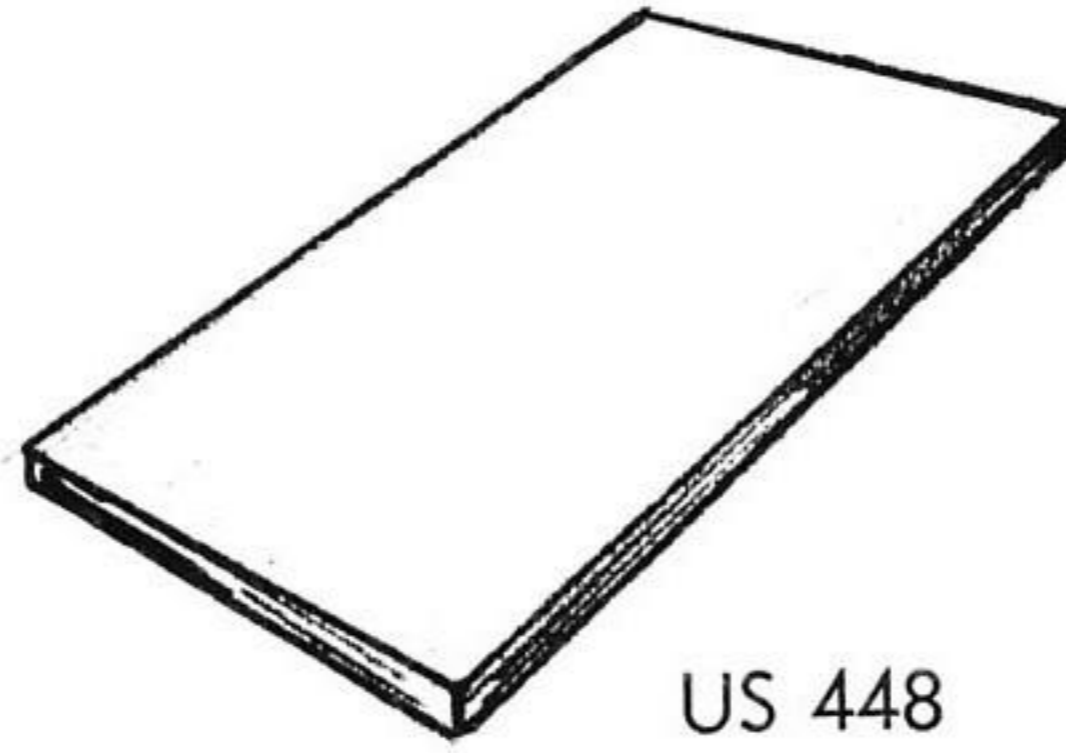

US 448

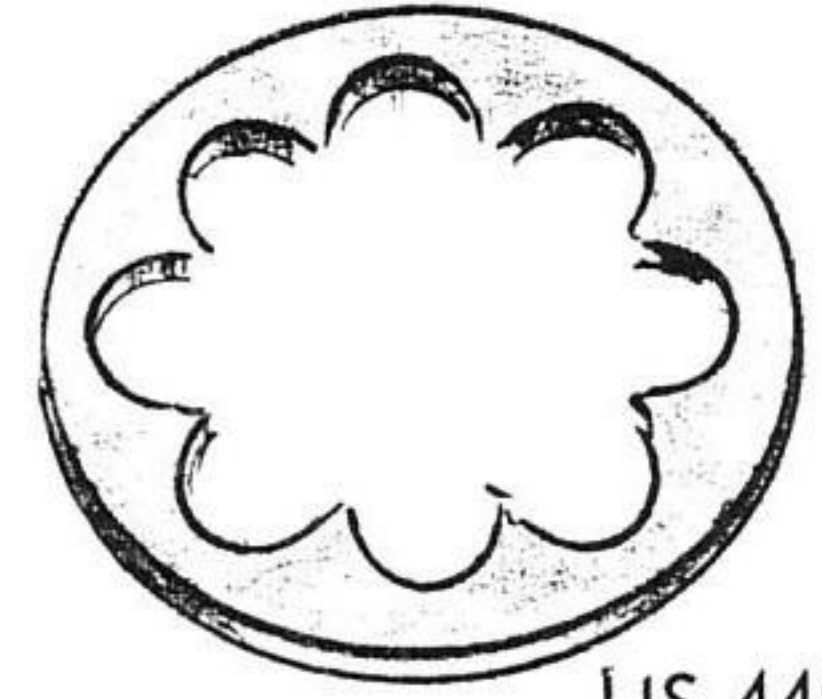

US 449 A

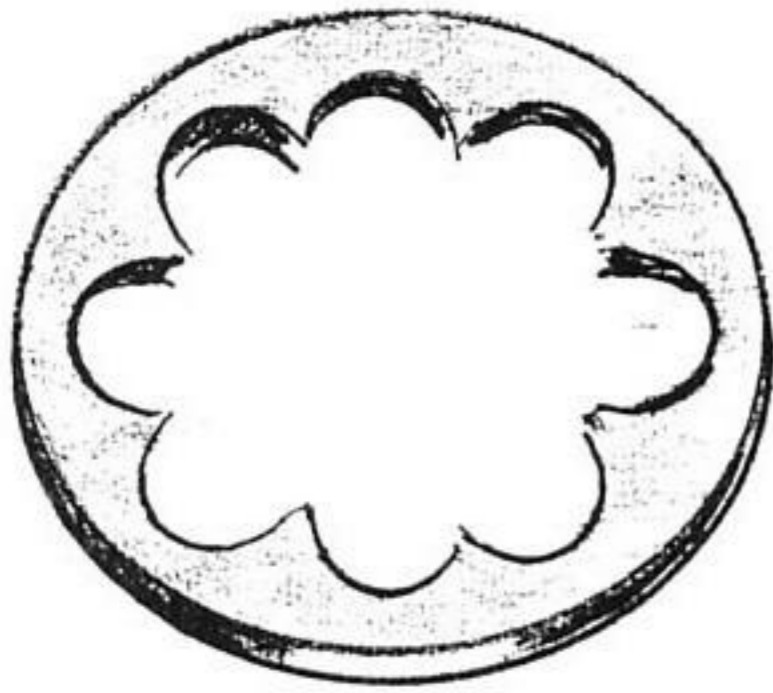

US 449 B

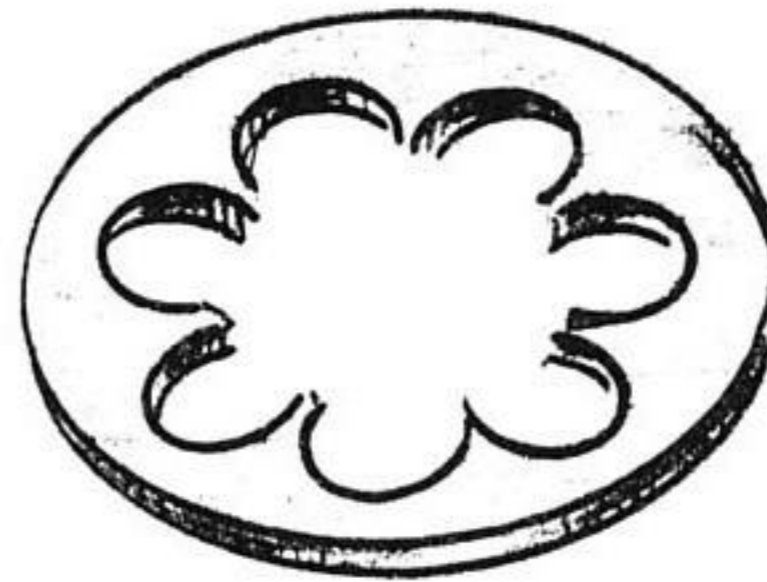

US 449 C

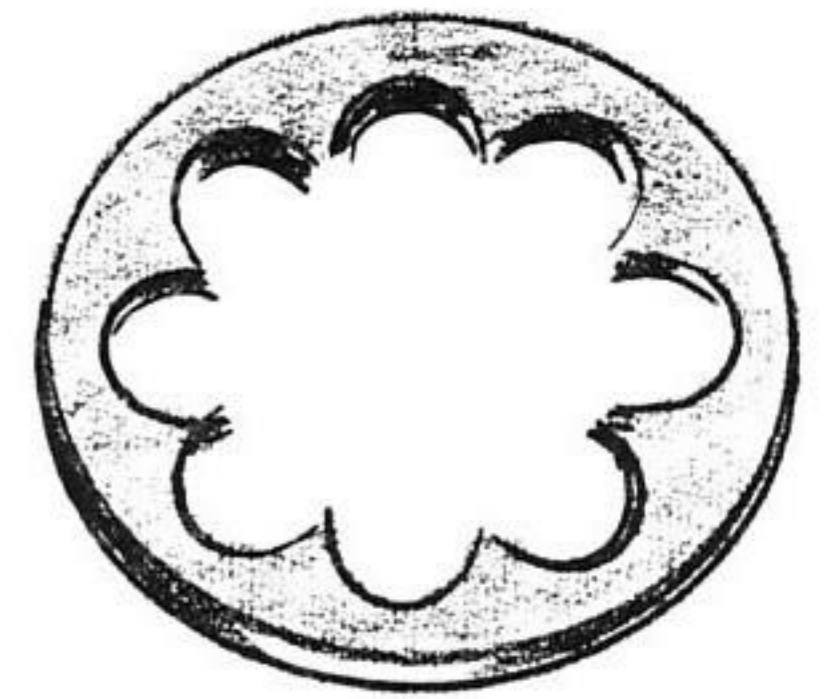

US 449 D

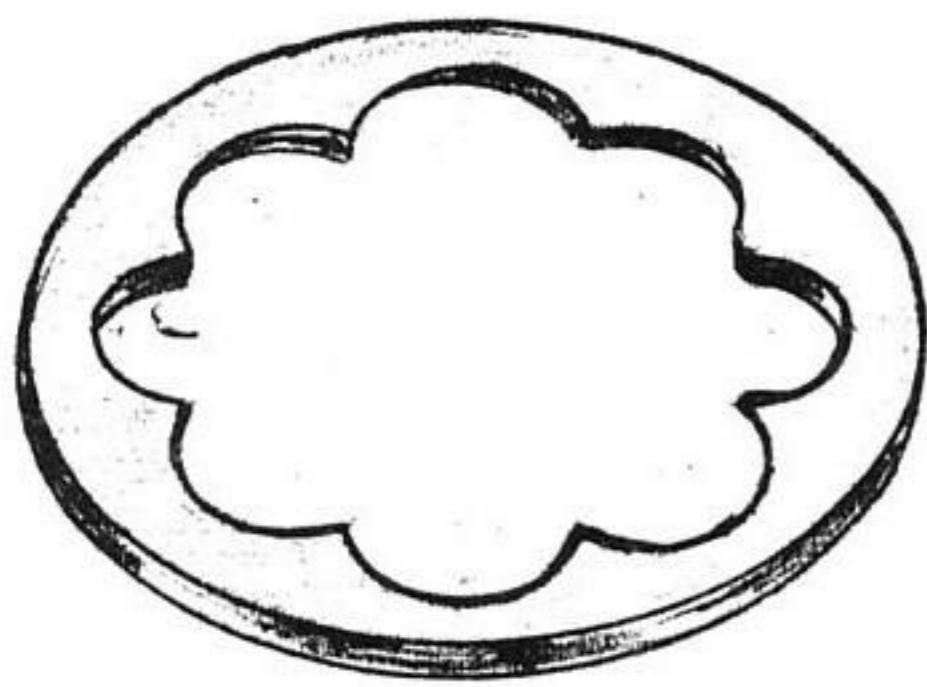

US 449 F



US 450 A

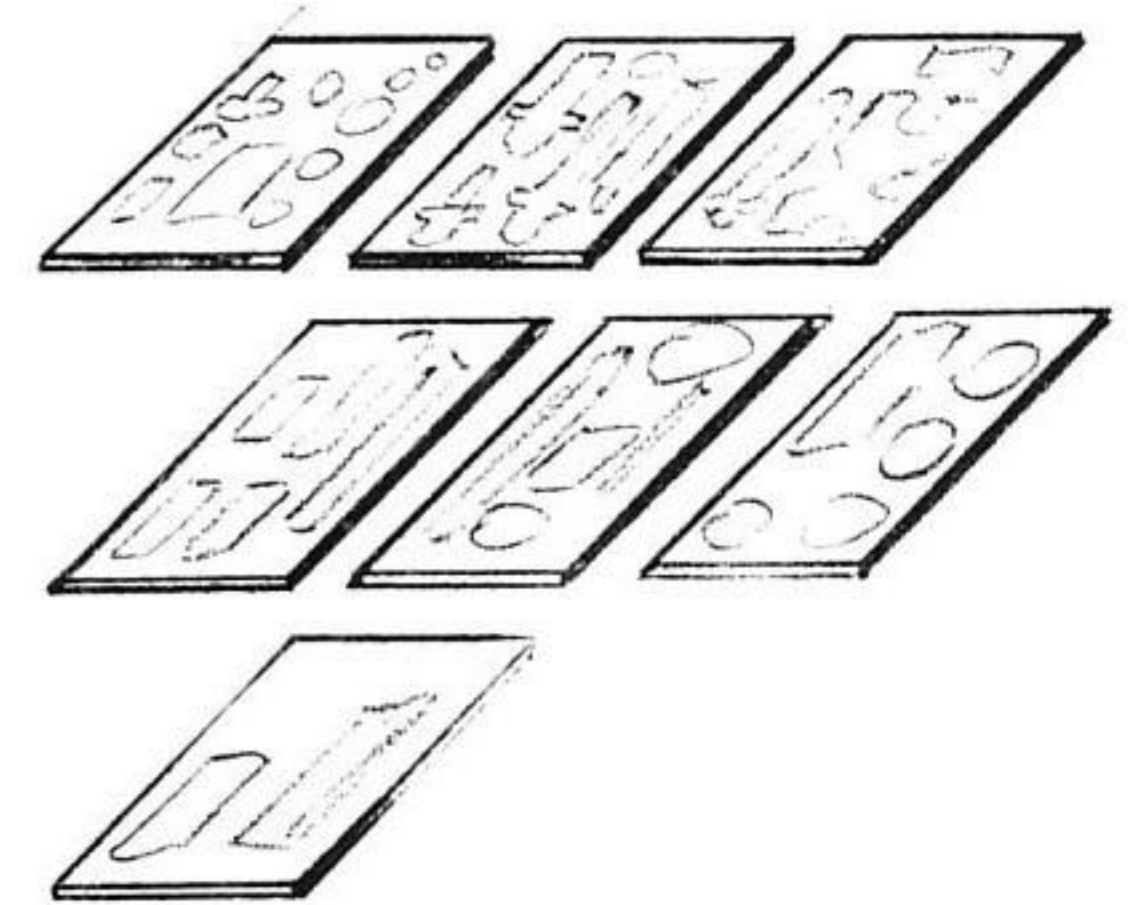

US 450 A-7

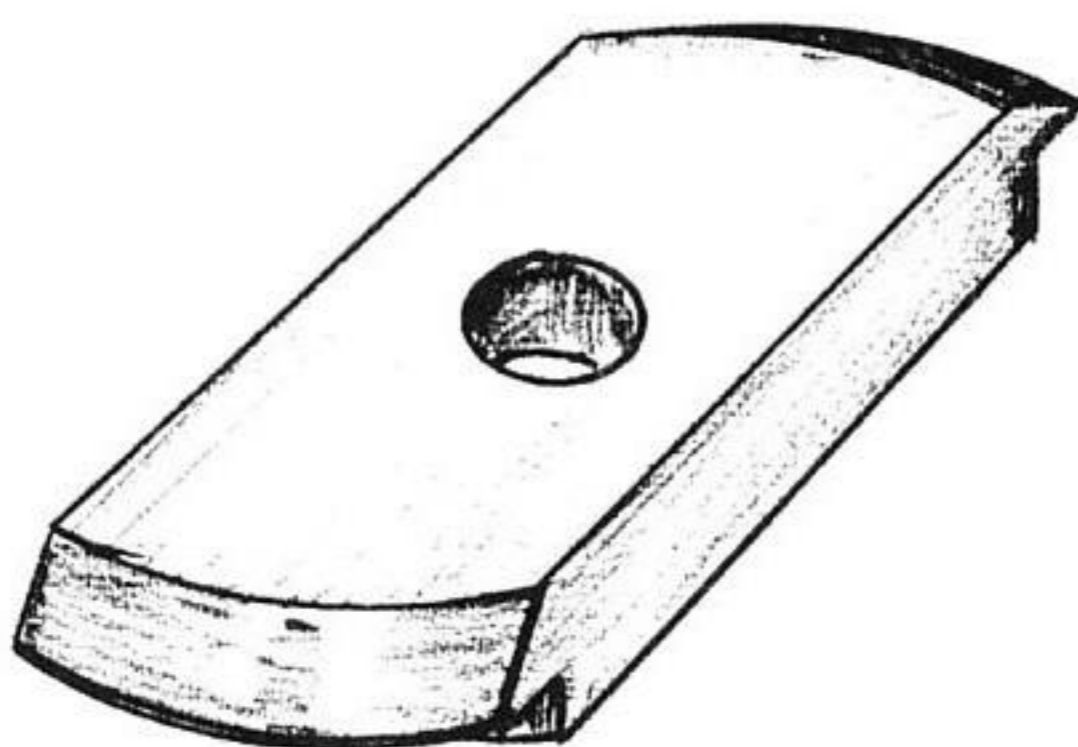

US 451

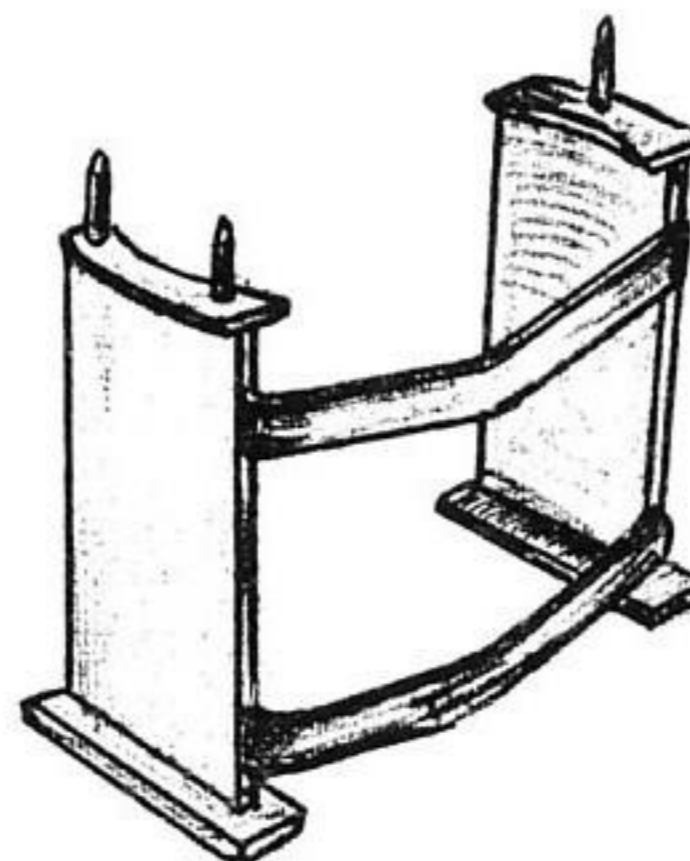

US 452

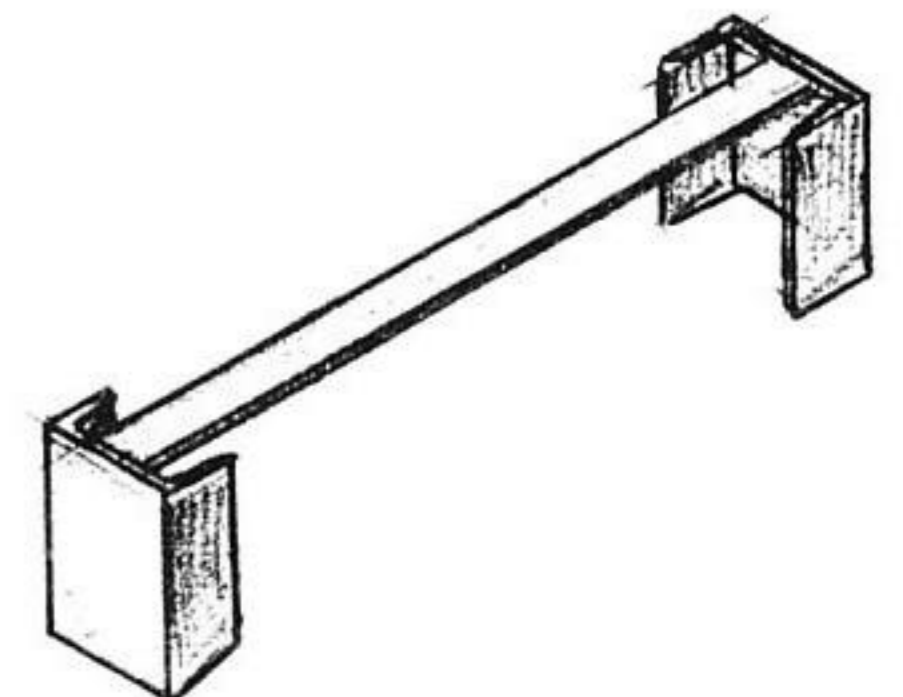

US 453

Special TOOLS

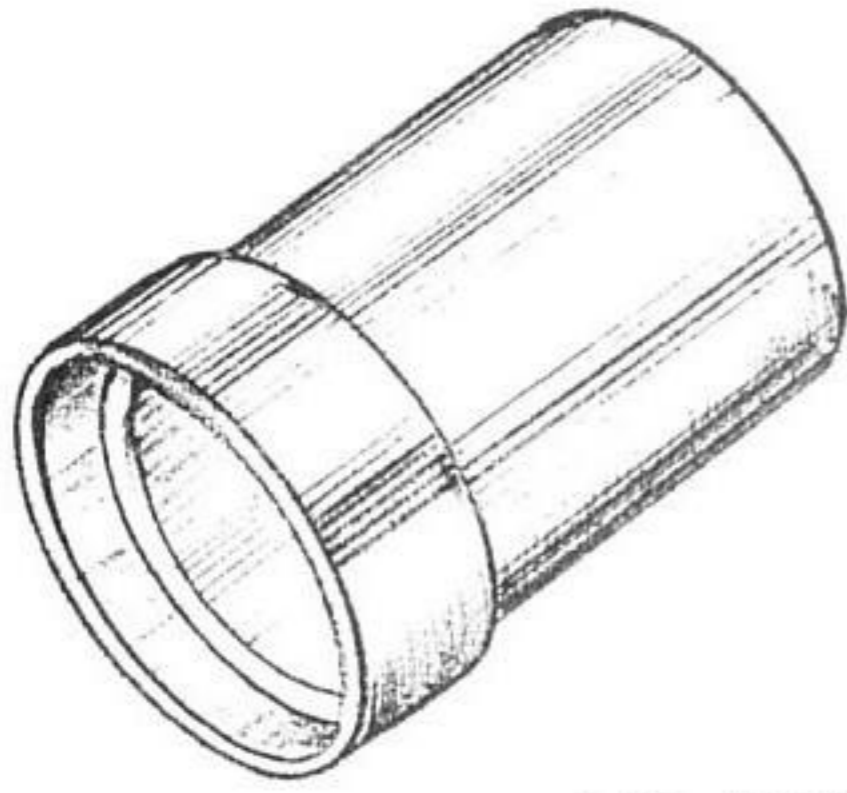

US 454

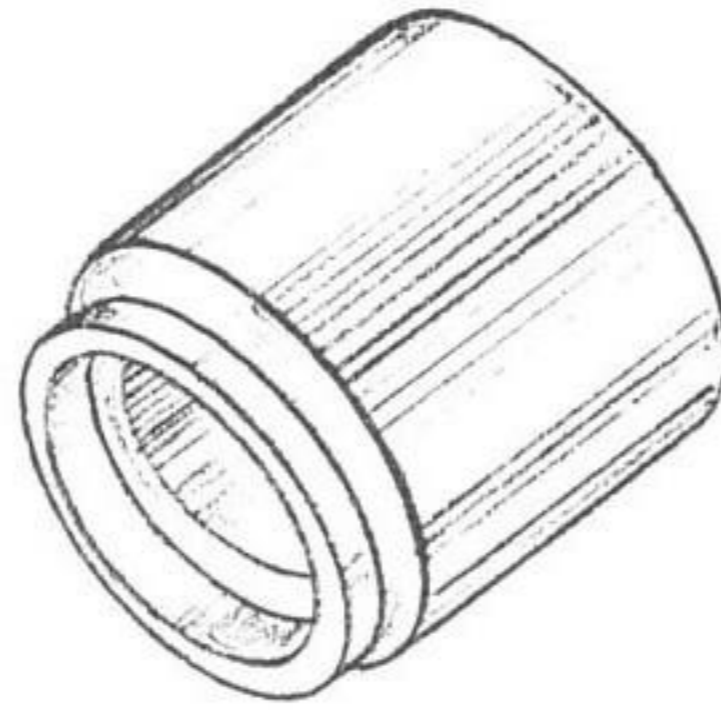

US 455

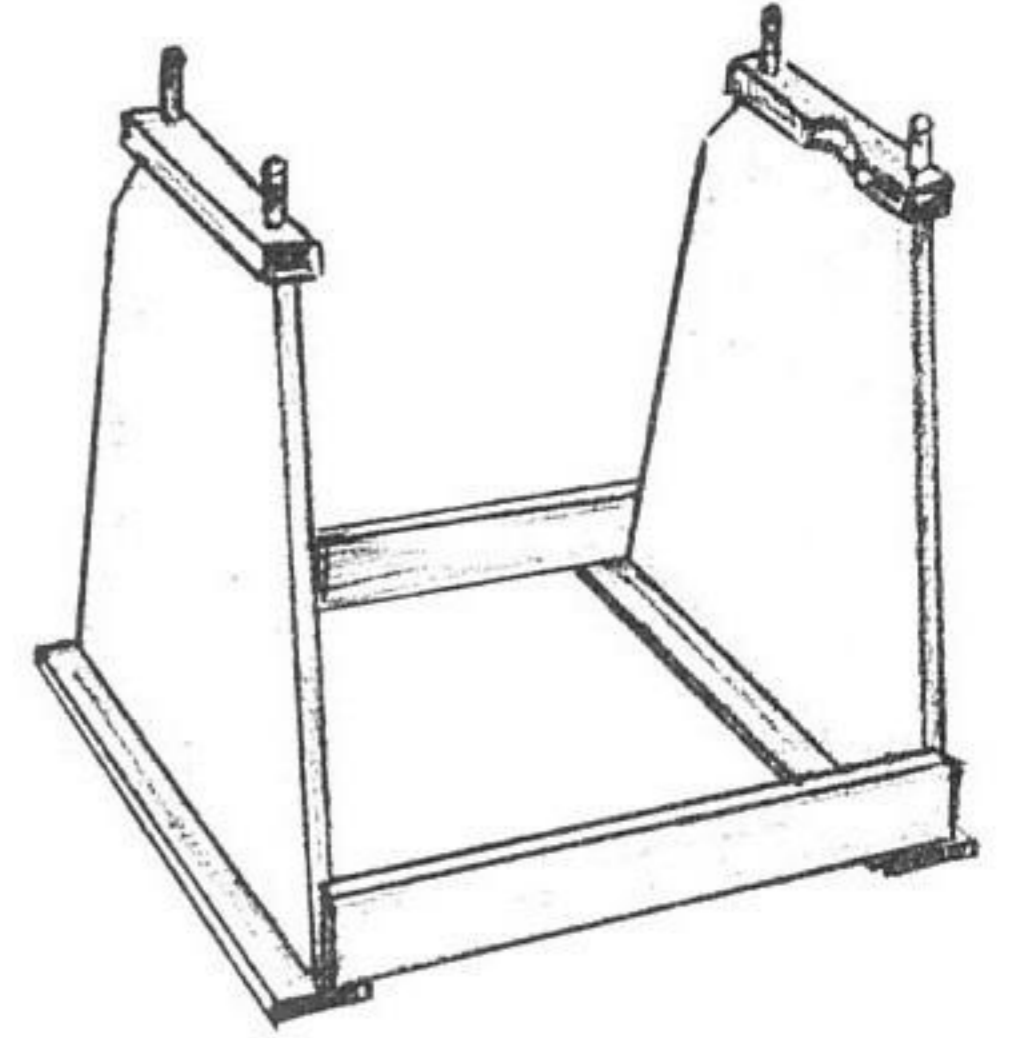

US 456

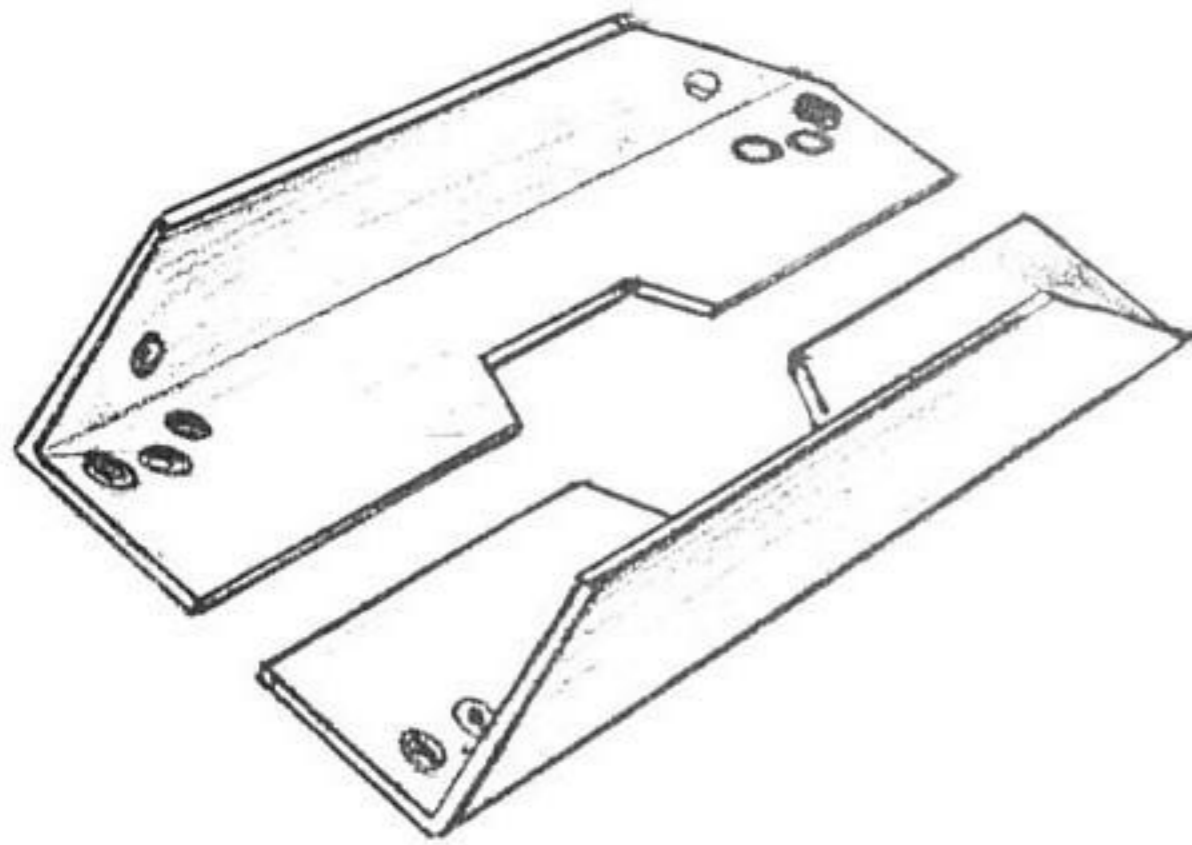

US 457

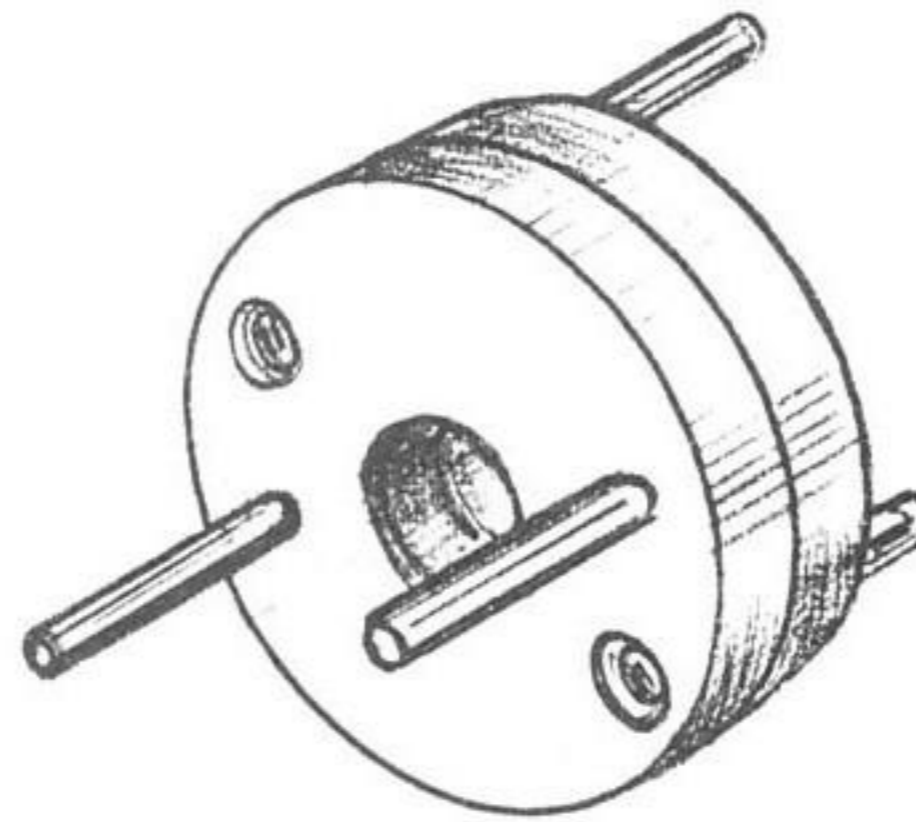

US 458

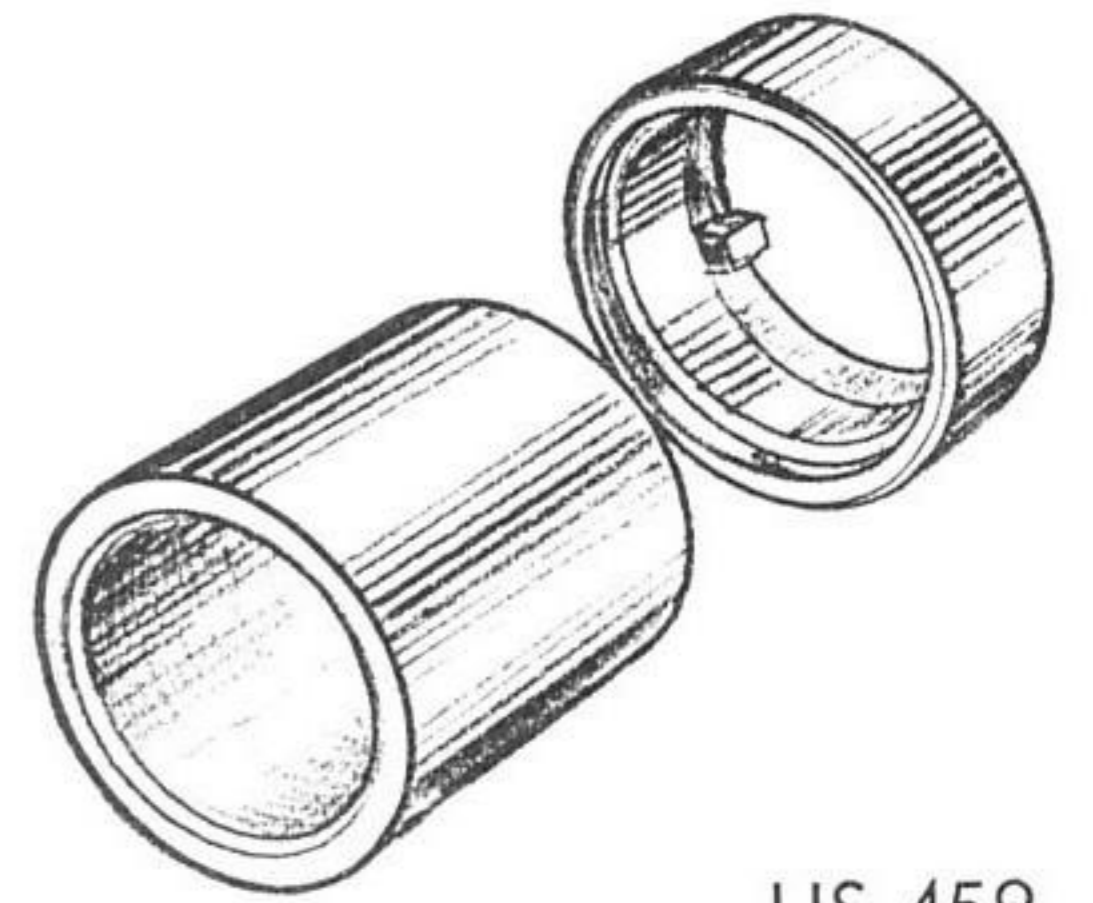

US 459

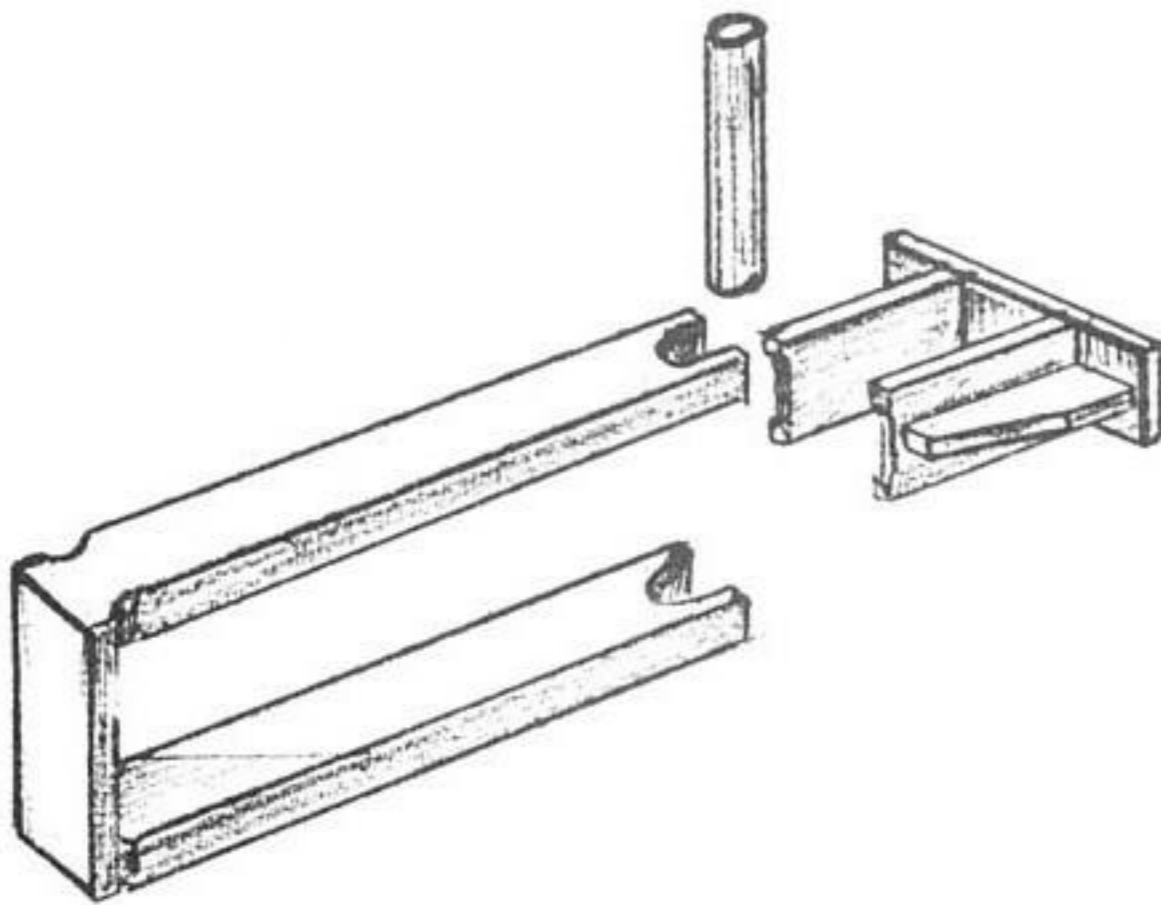

US 460

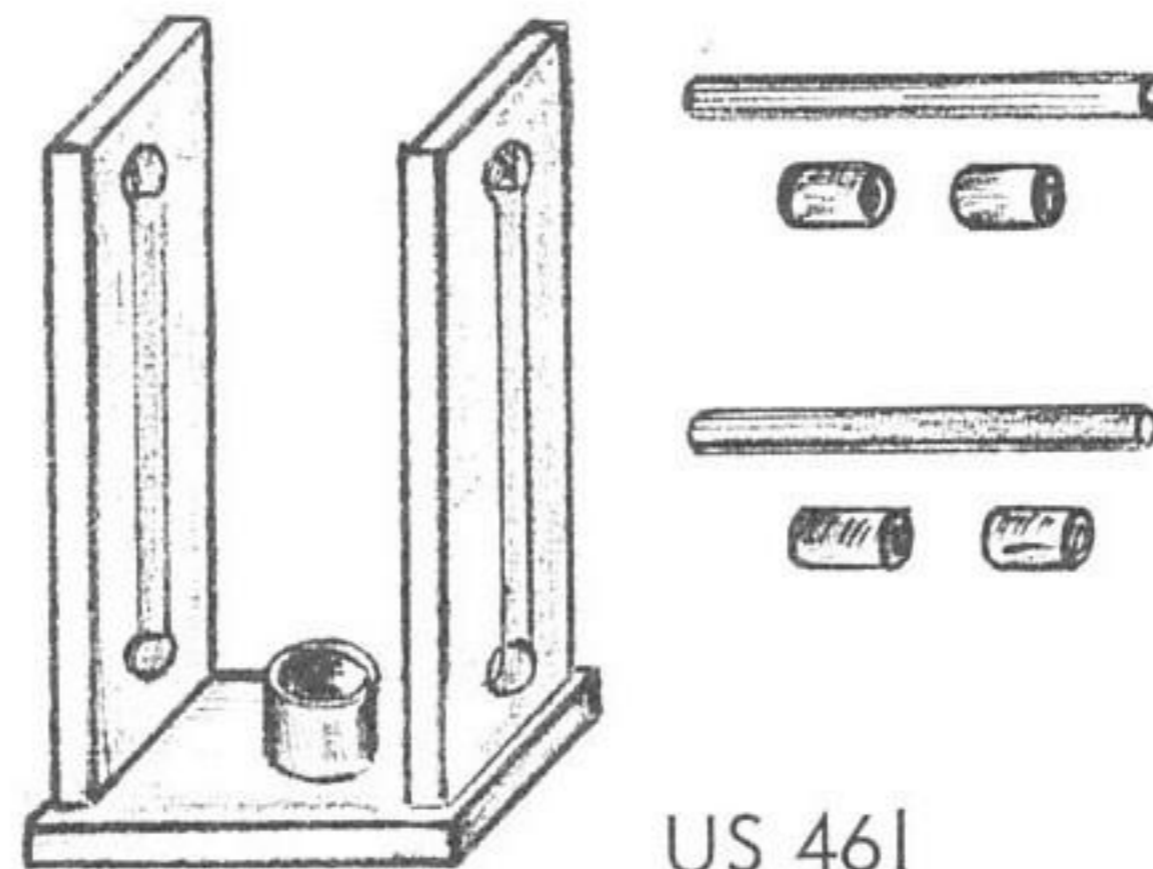

US 461

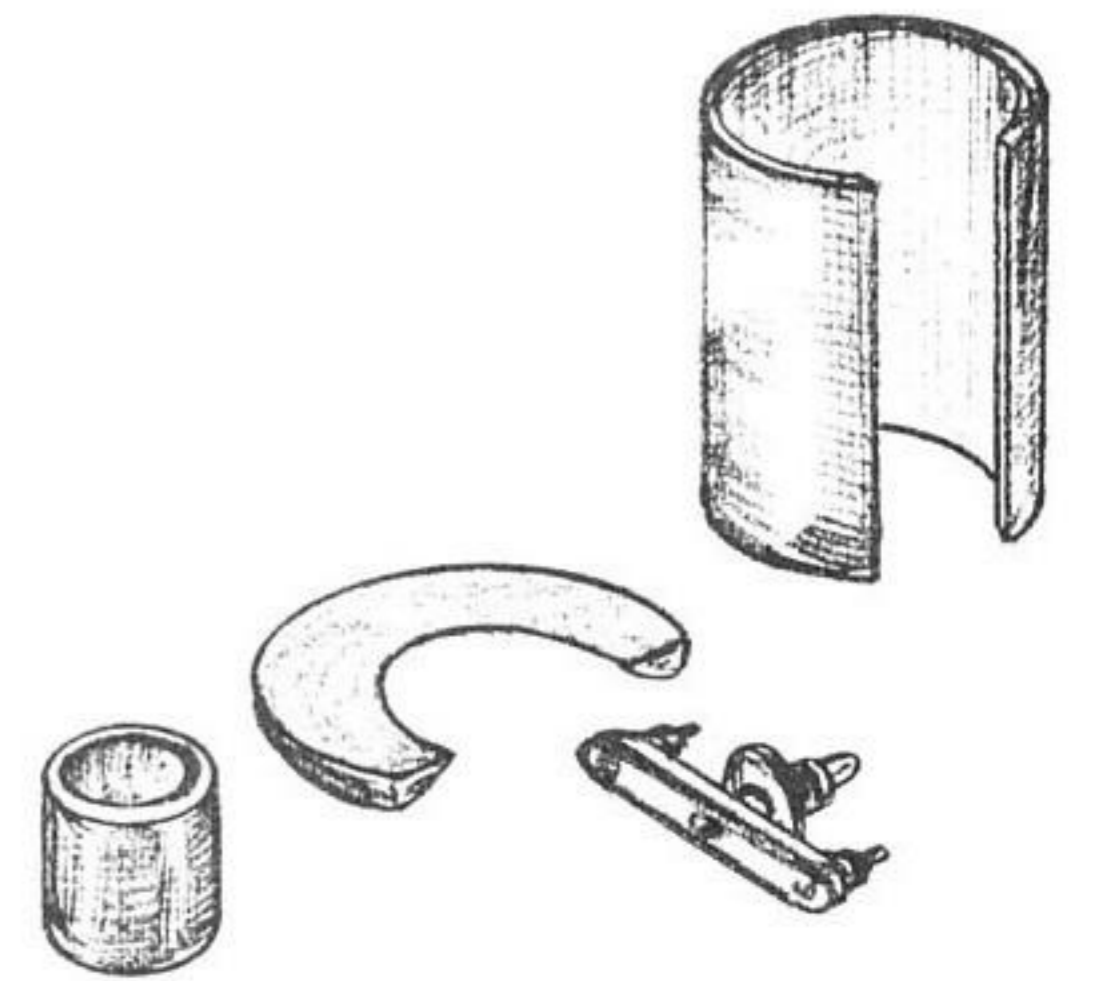

US 463

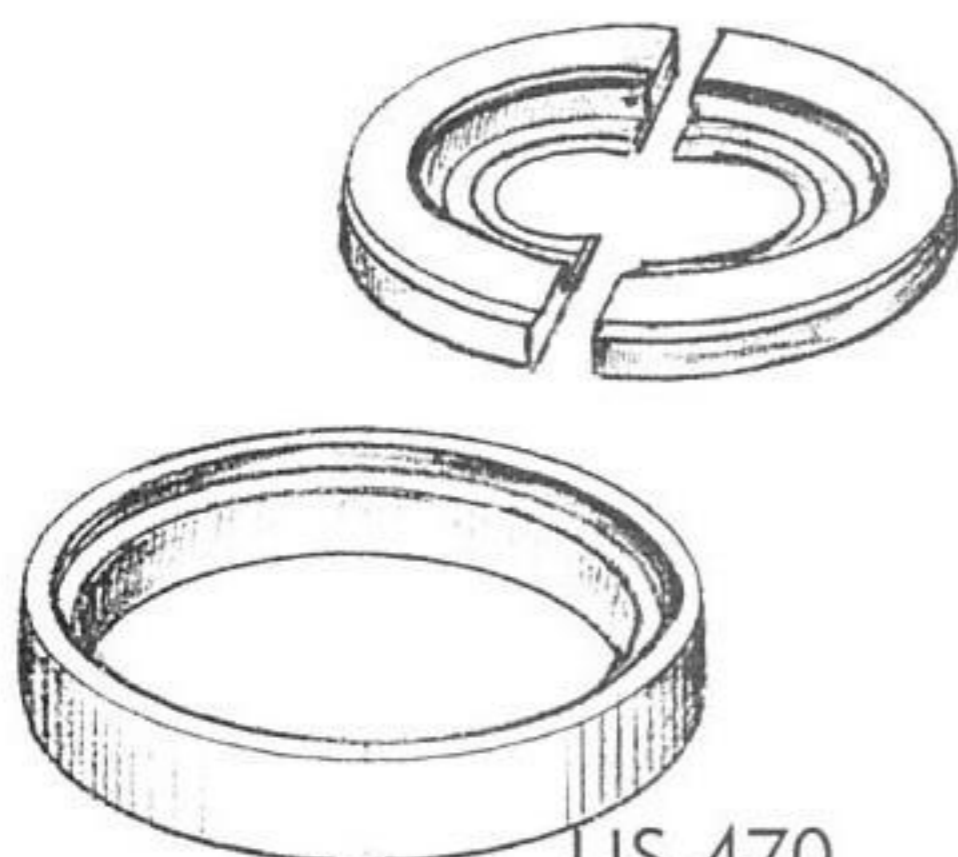

US 470

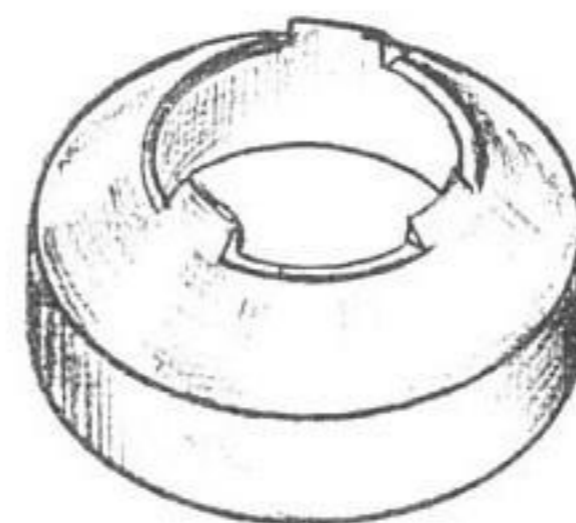

US 471

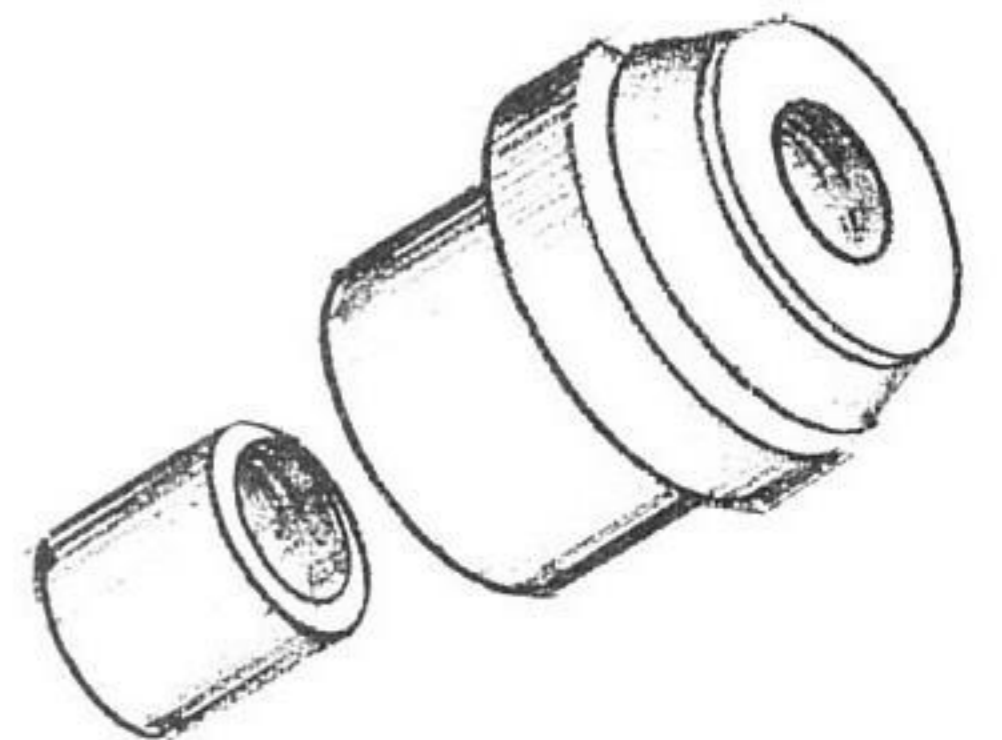

US 472

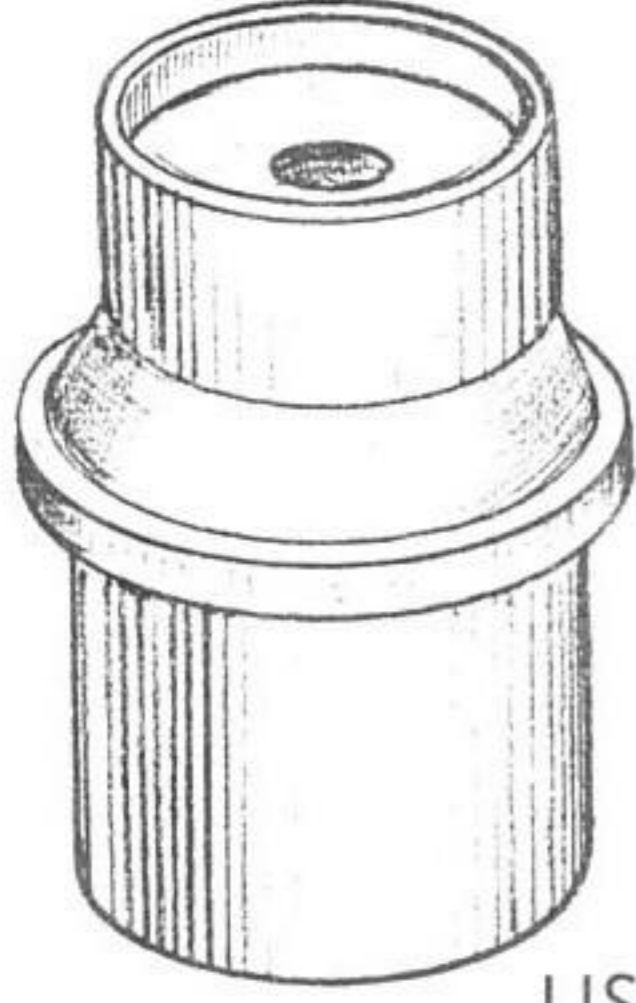

US 473



Special TOOLS

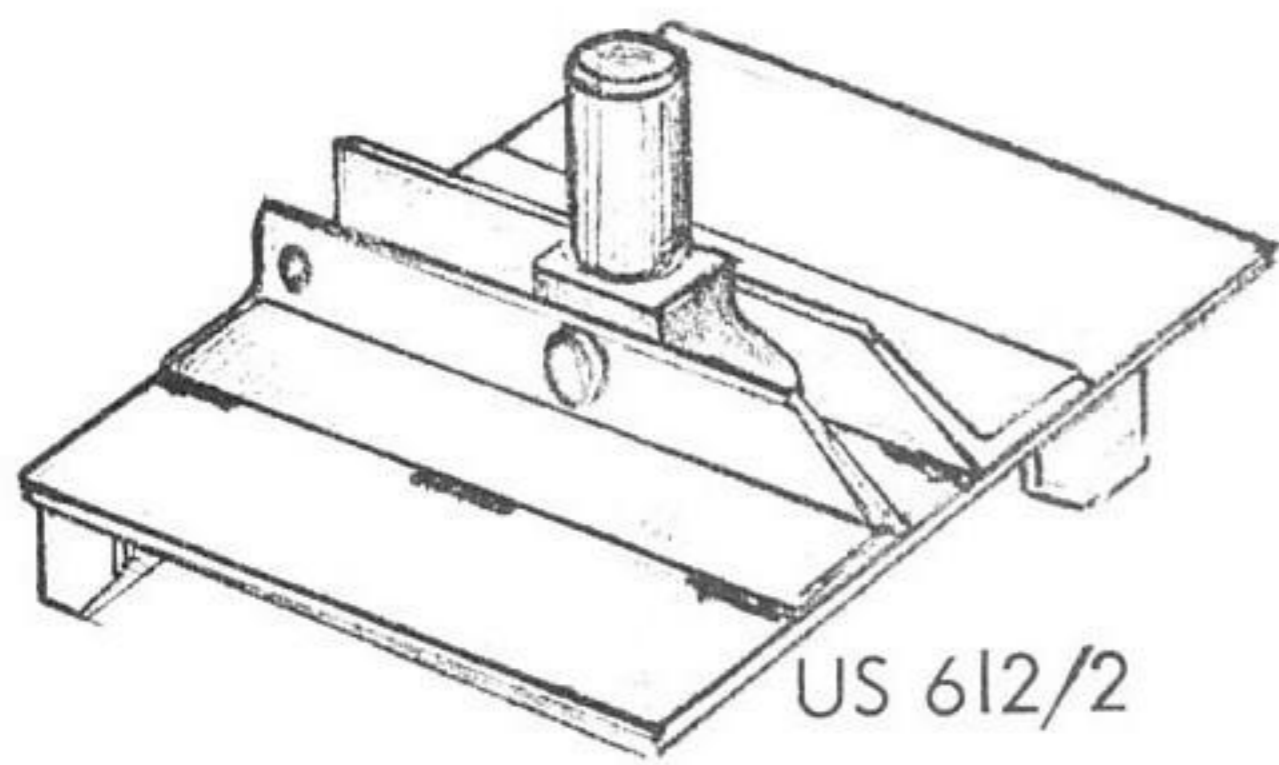

US 612/2

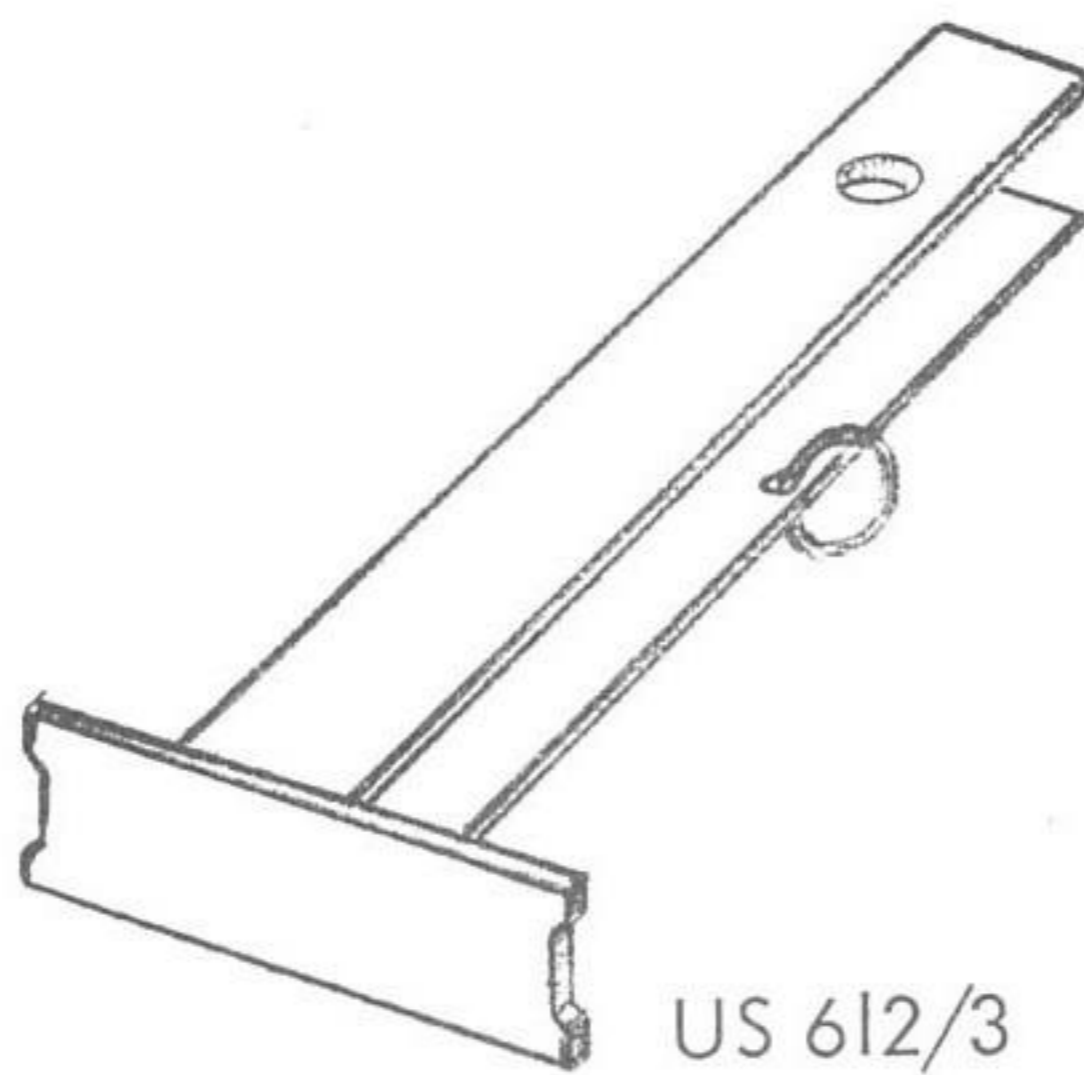

US 612/3

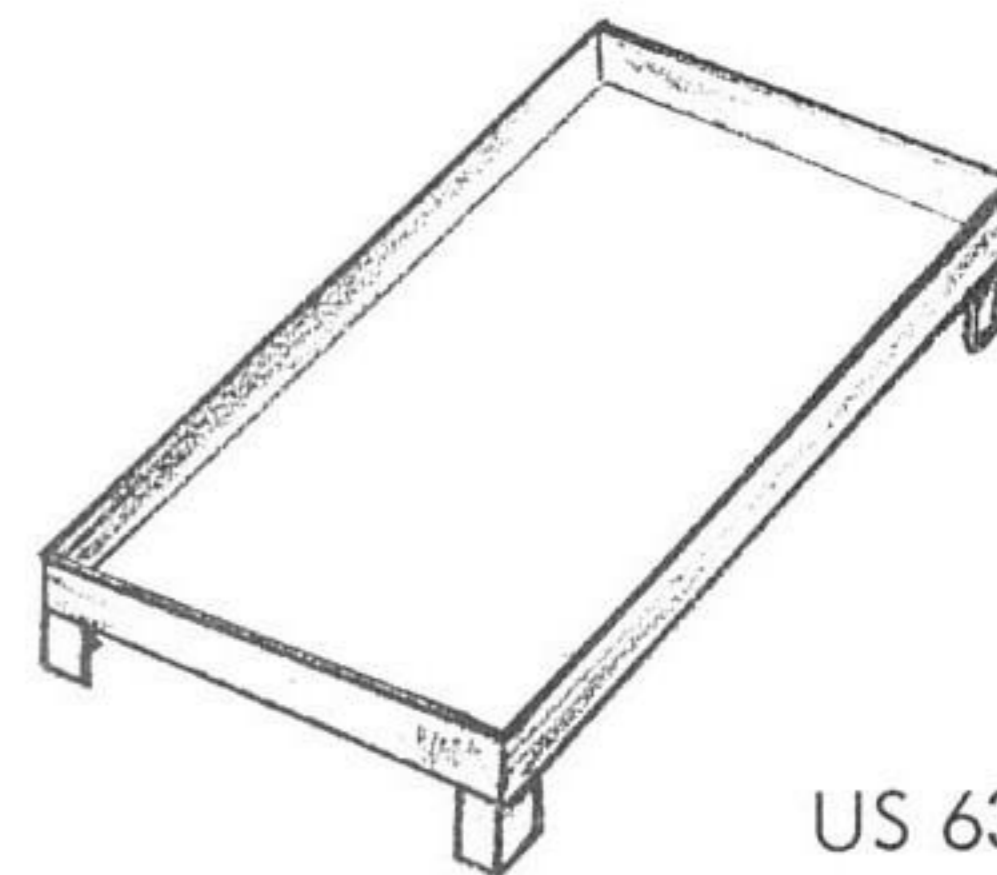

US 631

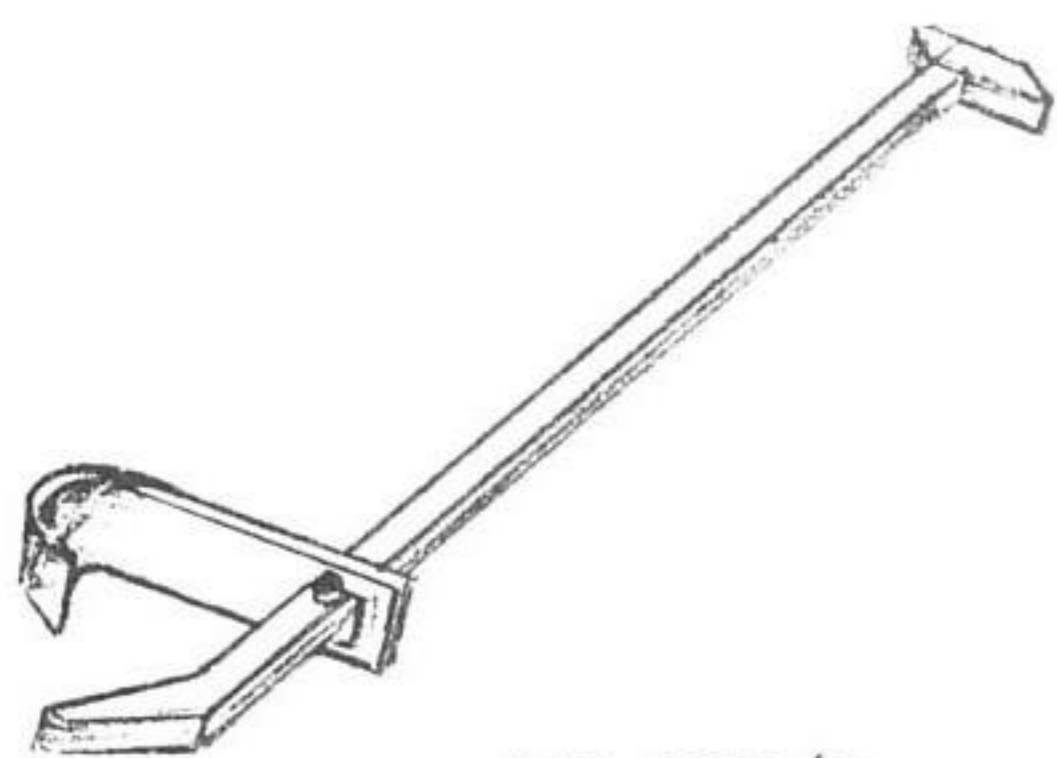

US 637/2



US 638

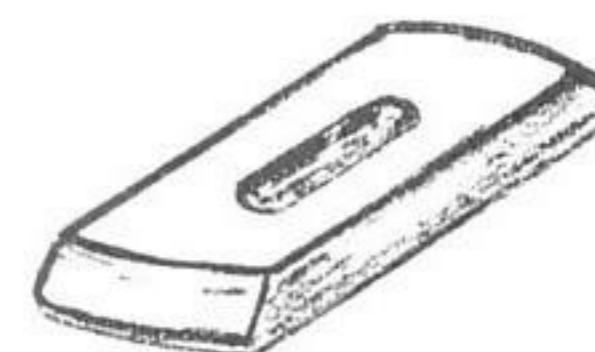

US 638/6

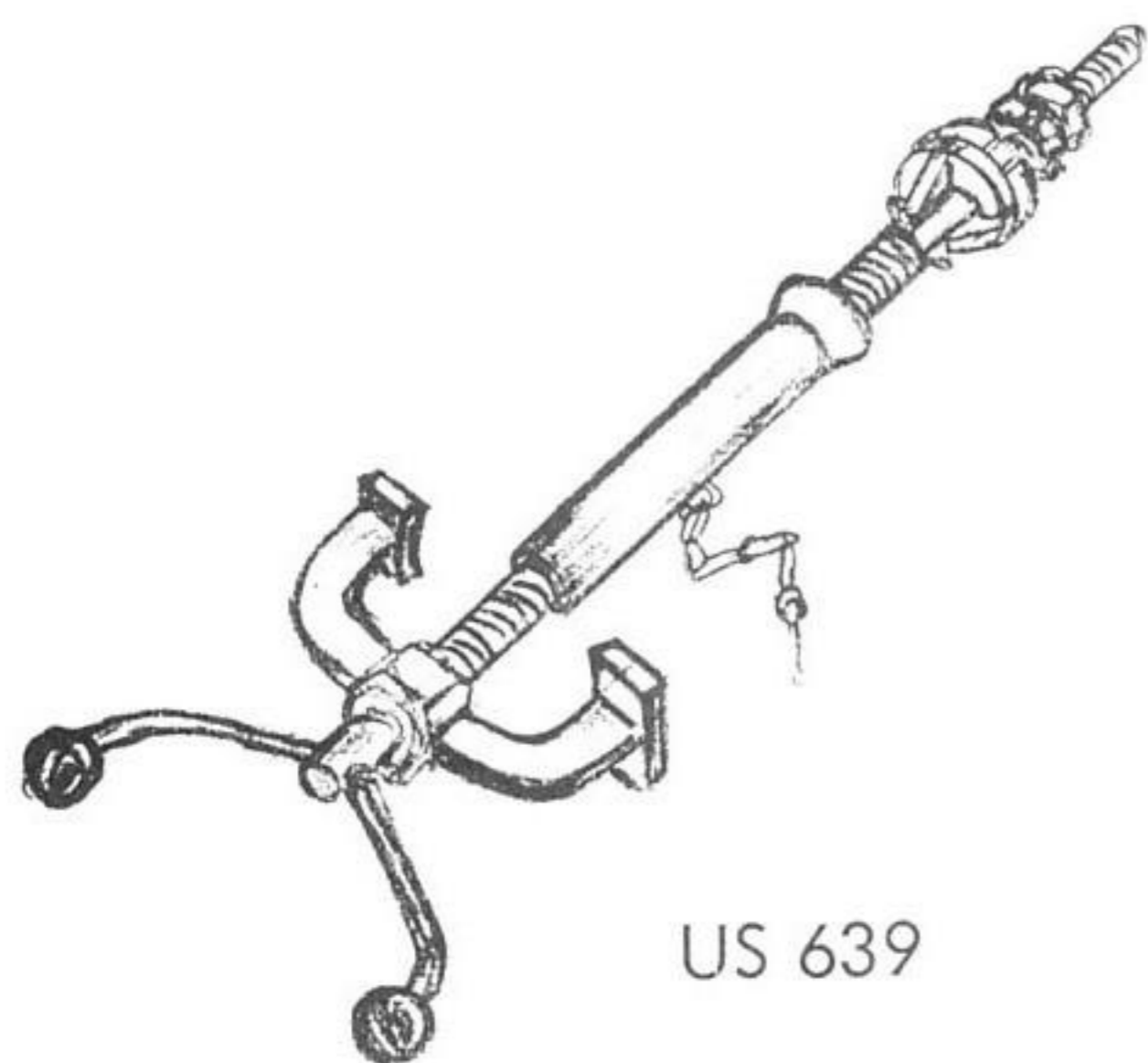

US 639

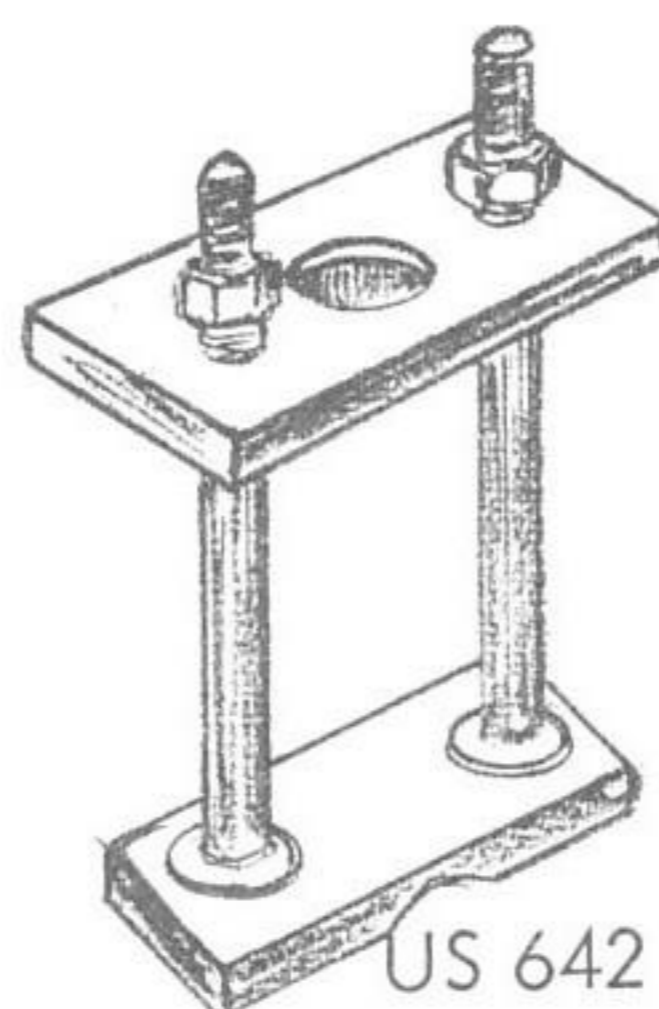

US 642



US 644

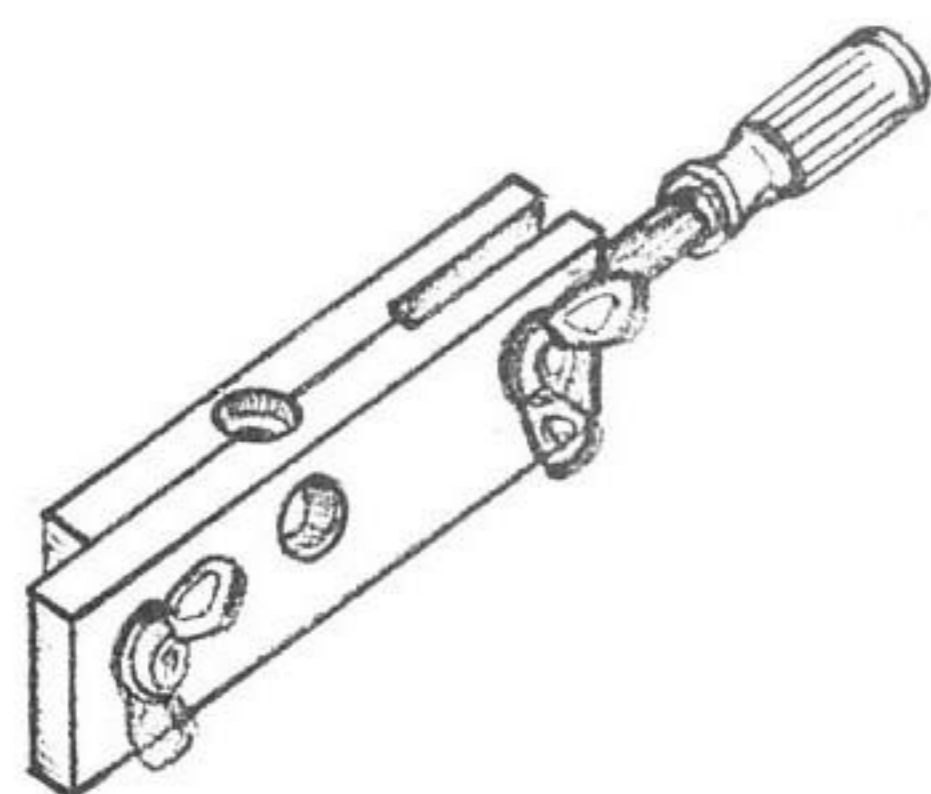

US 646/1

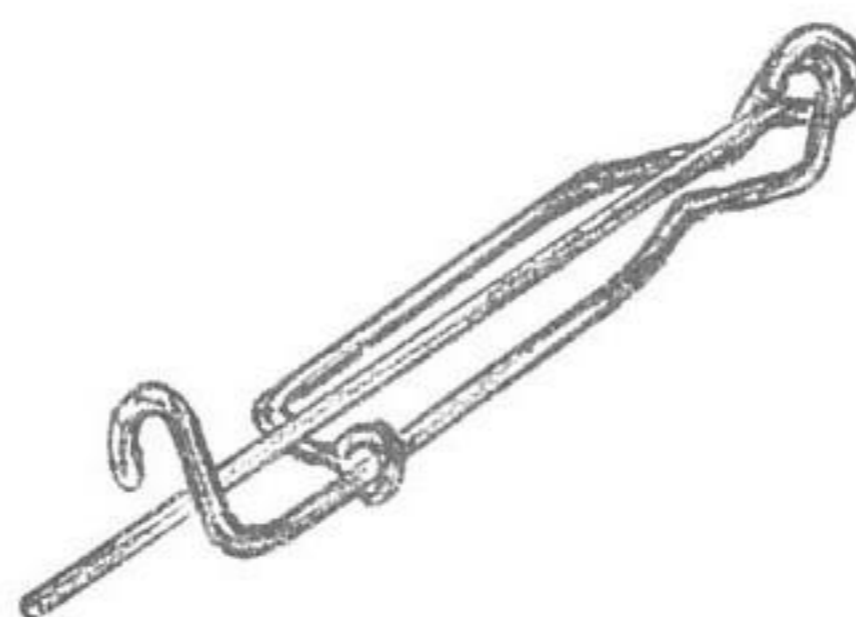

US 647

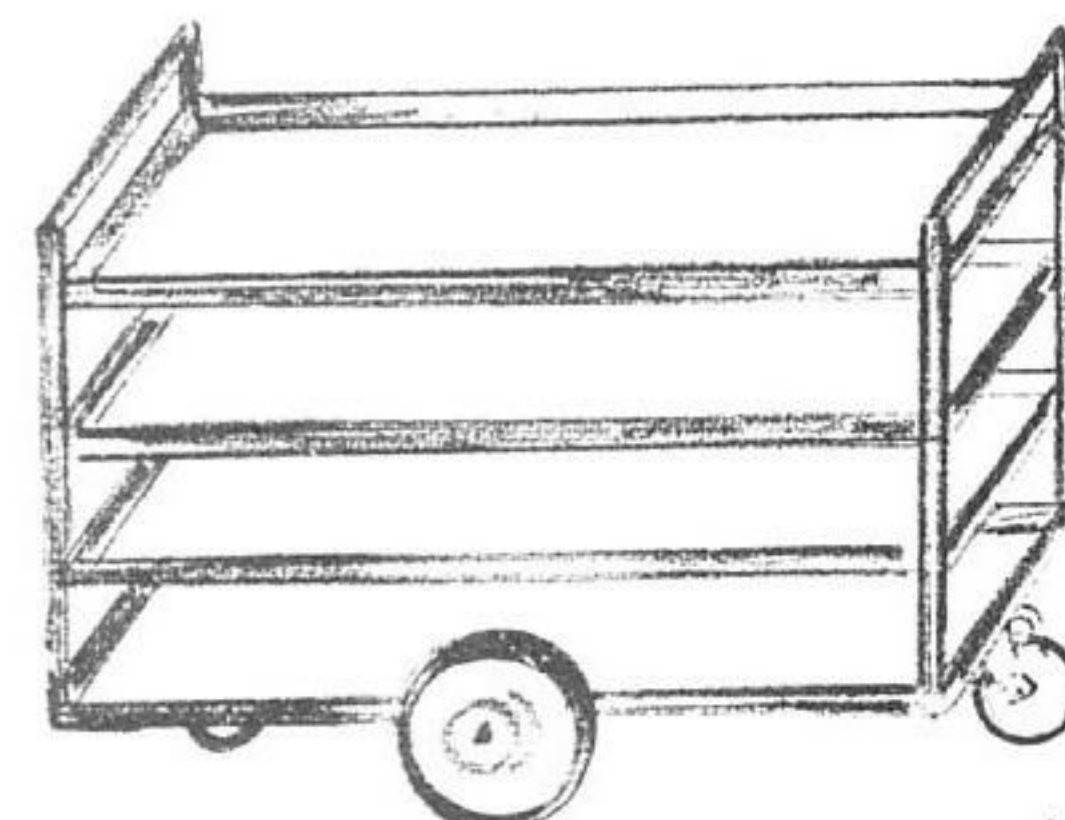

US 651

Special TOOLS

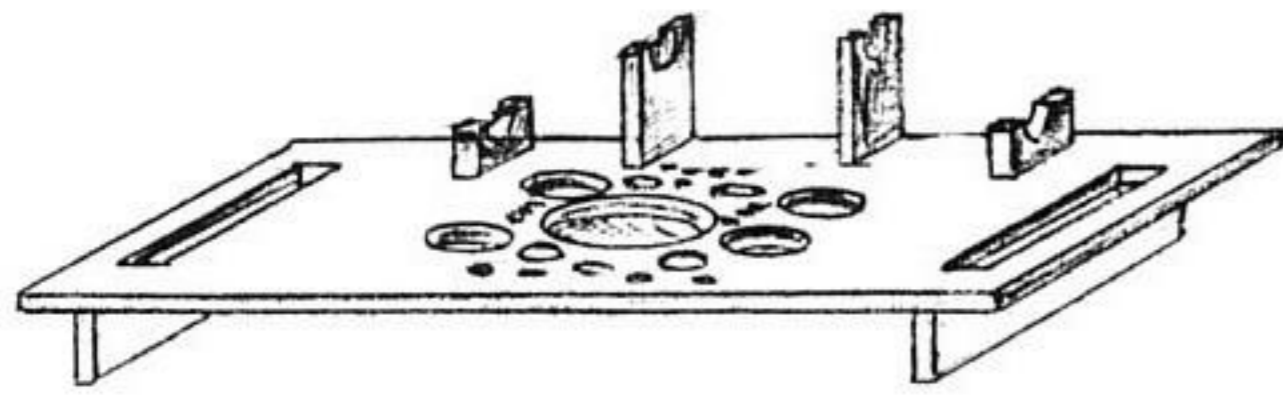

US 652/3

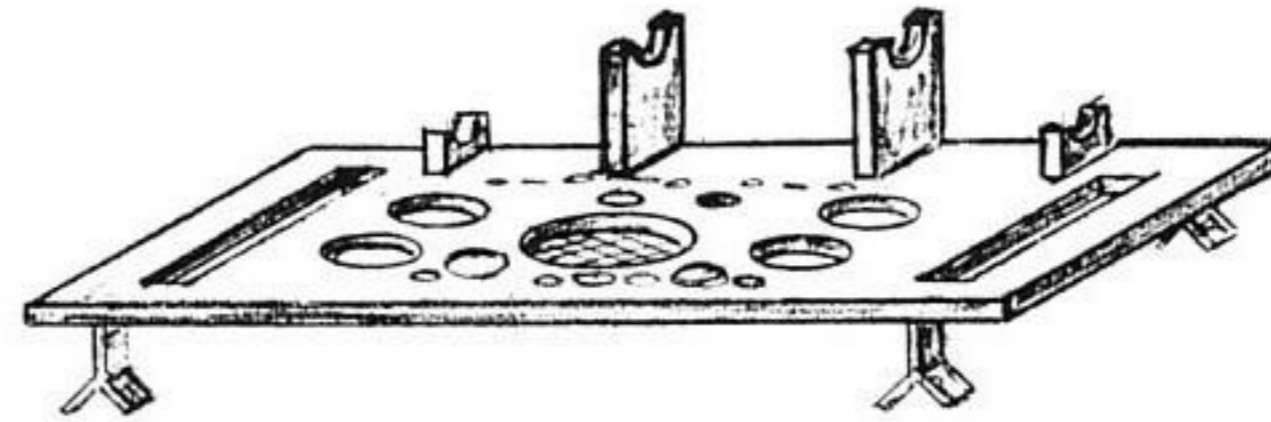

US 652/5

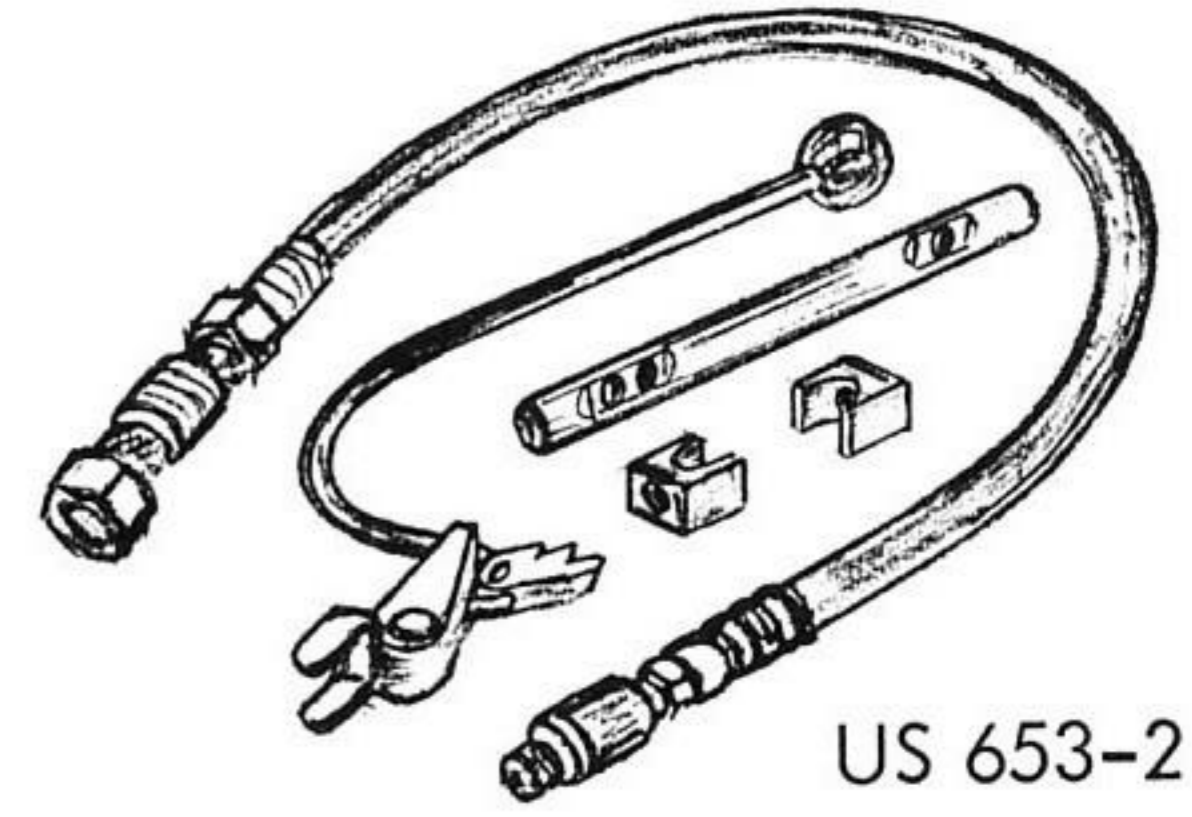

US 653-2

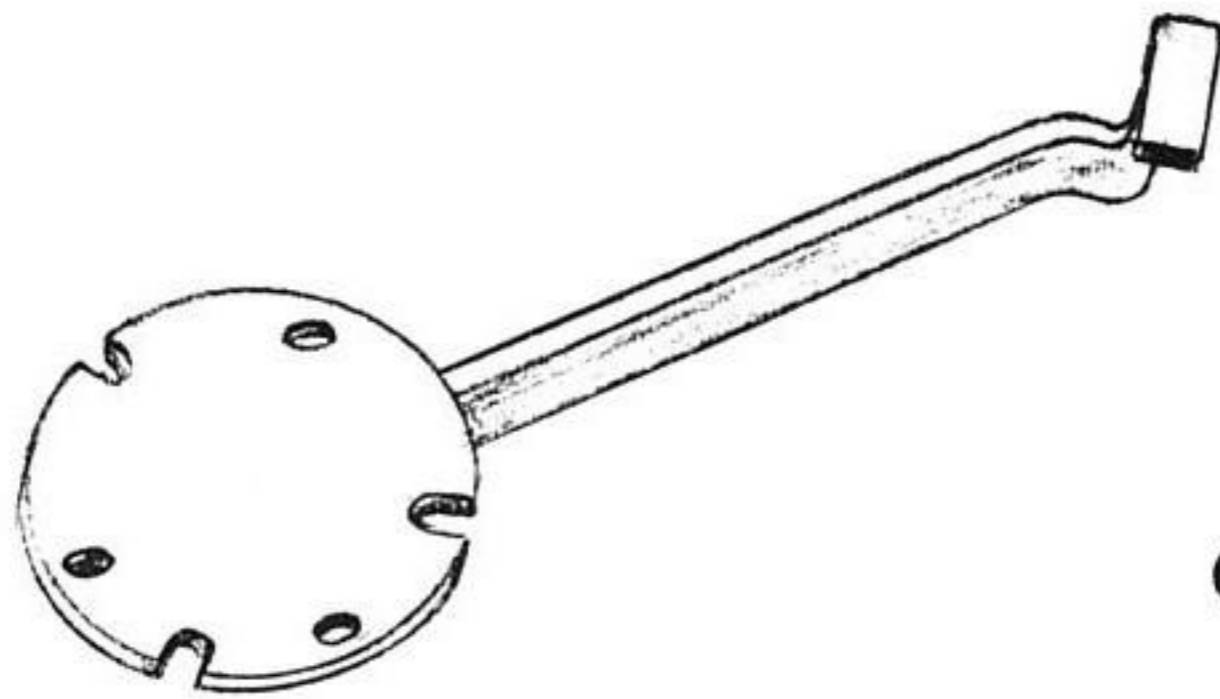

US 654

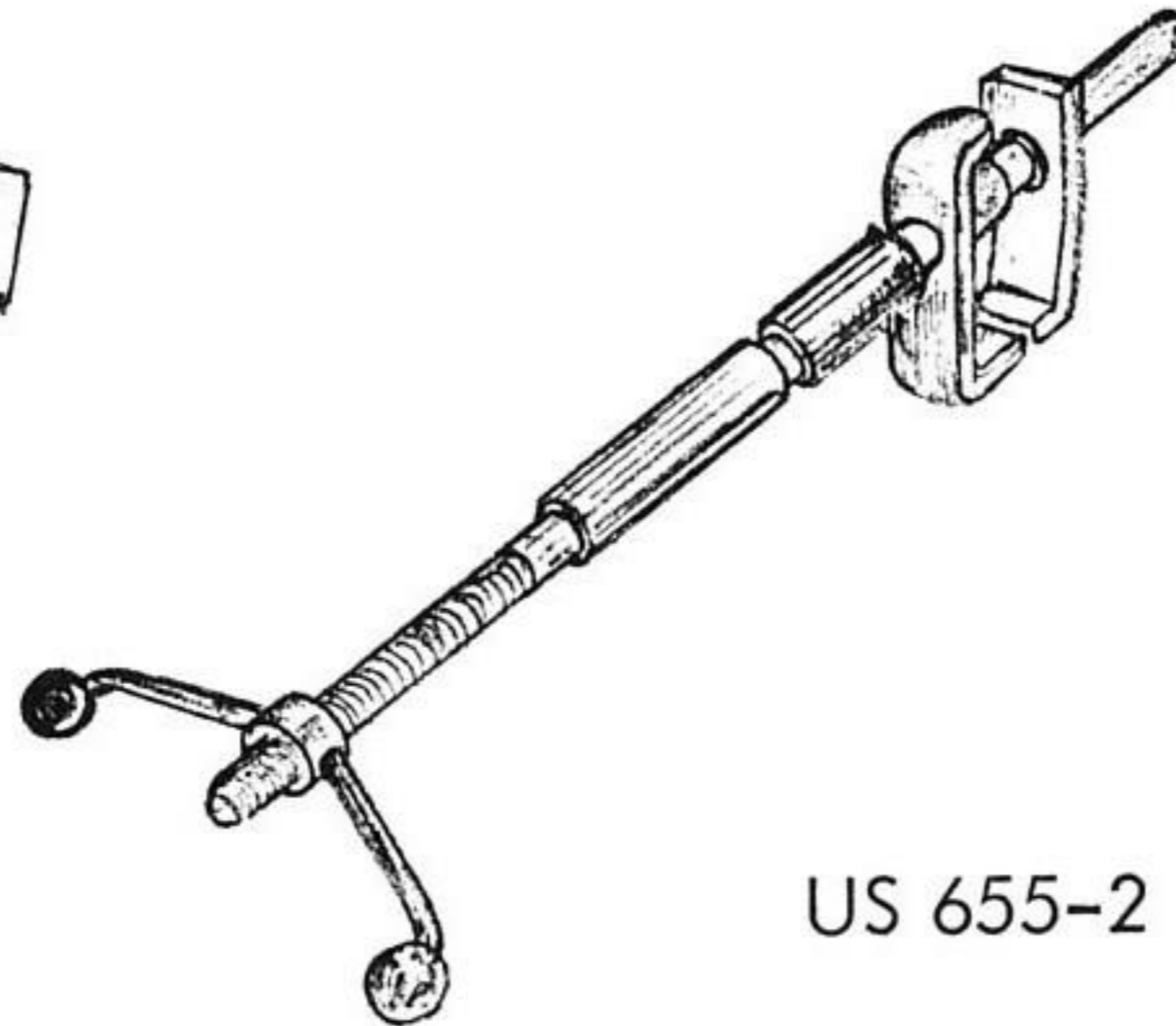

US 655-2

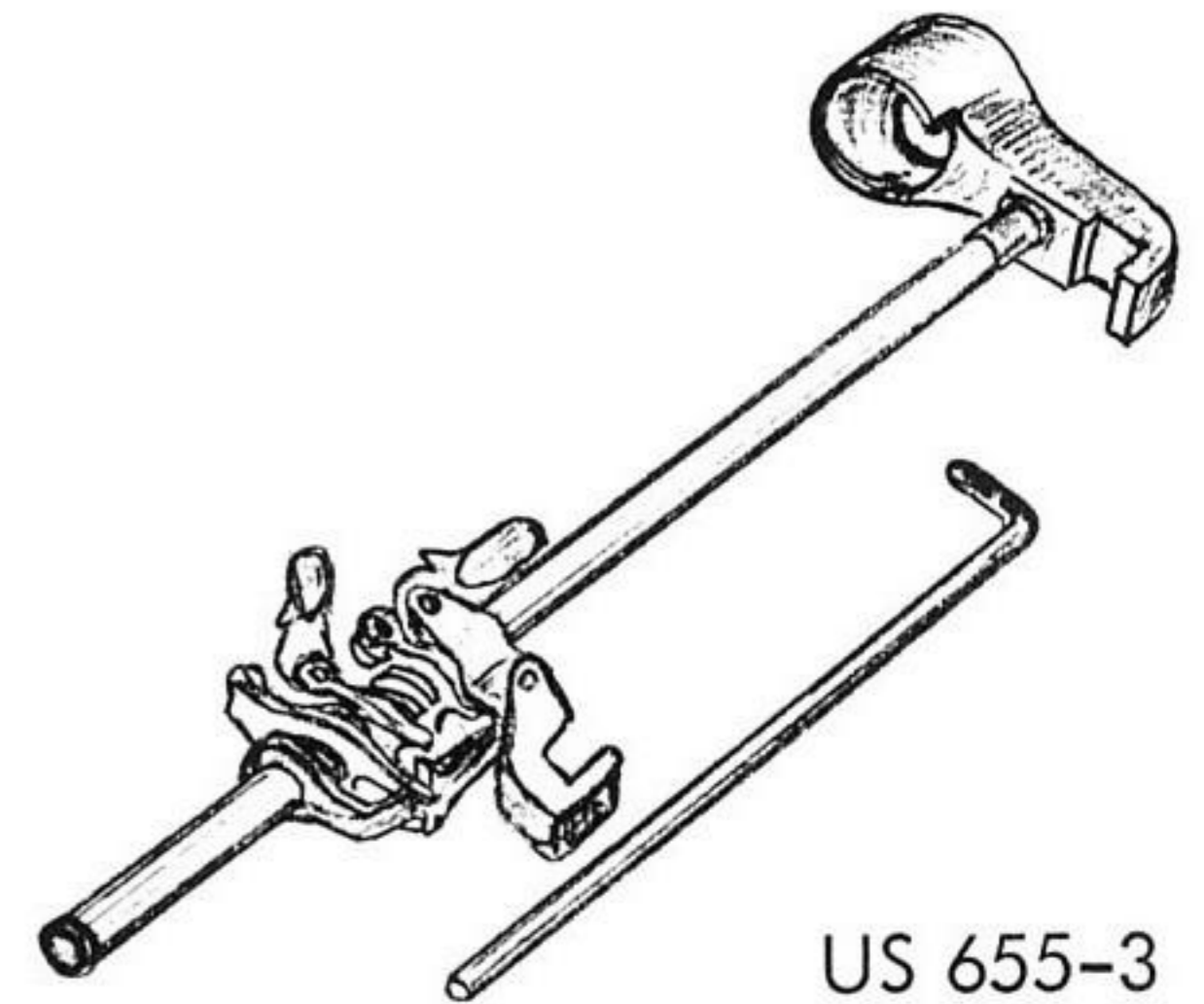

US 655-3

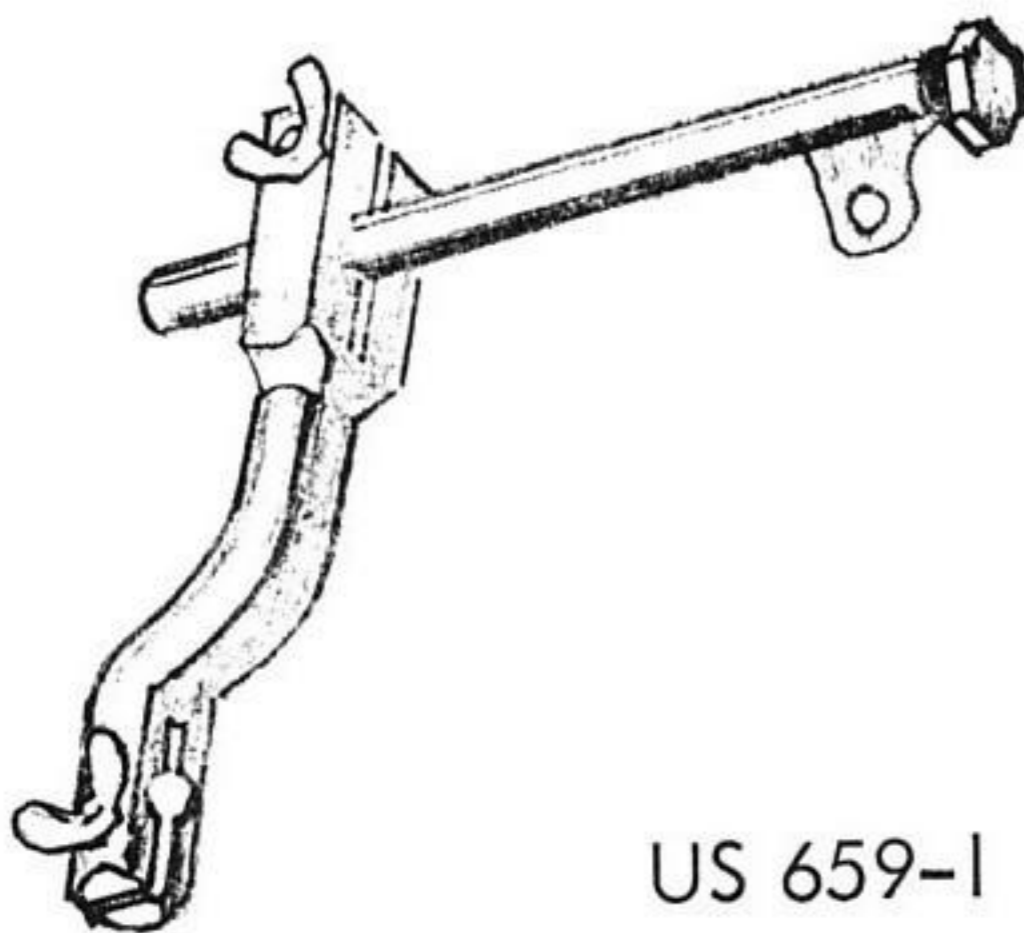

US 659-1

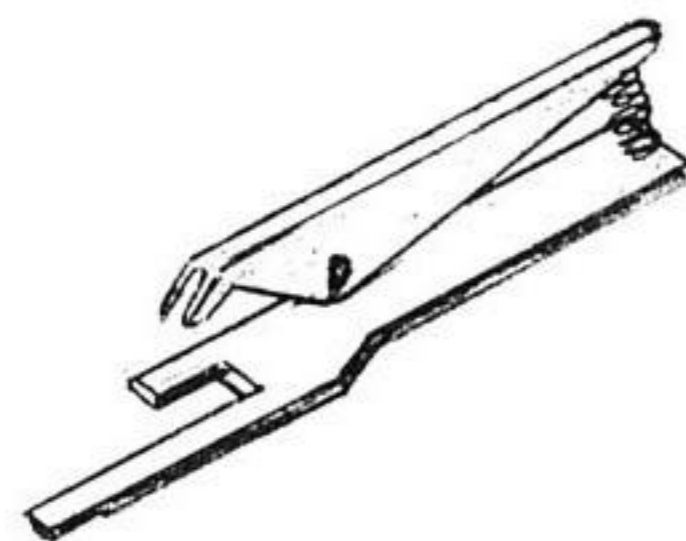

US 660

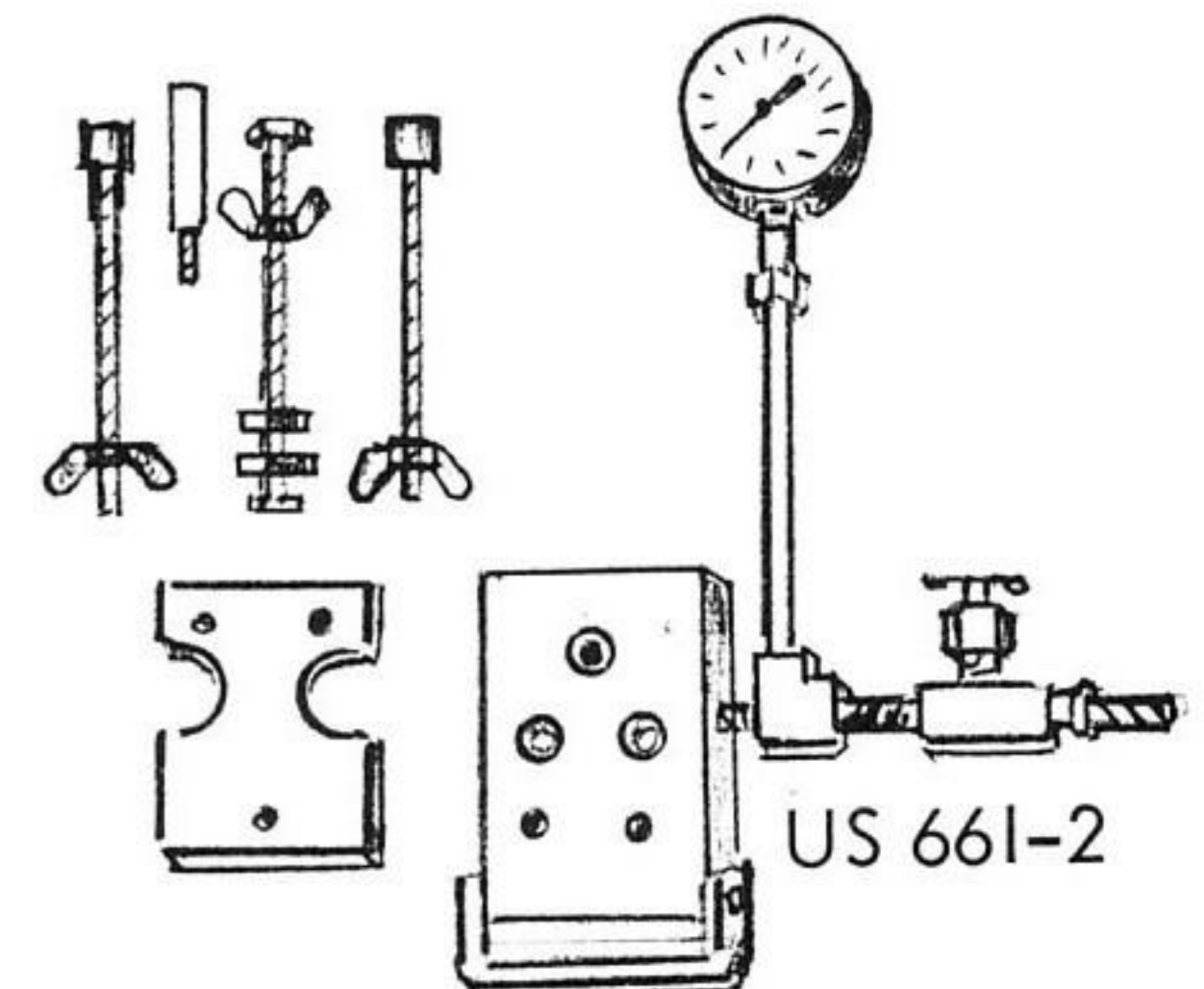

US 661-2

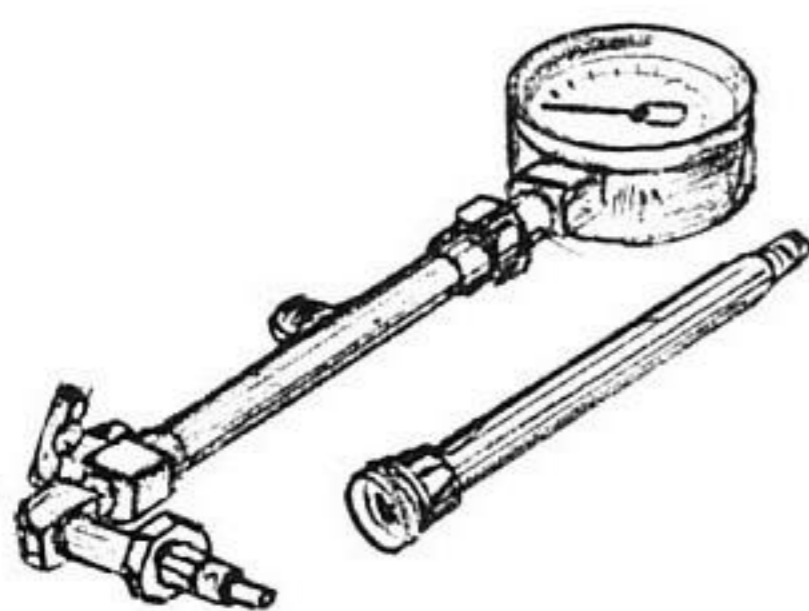

US 662-2

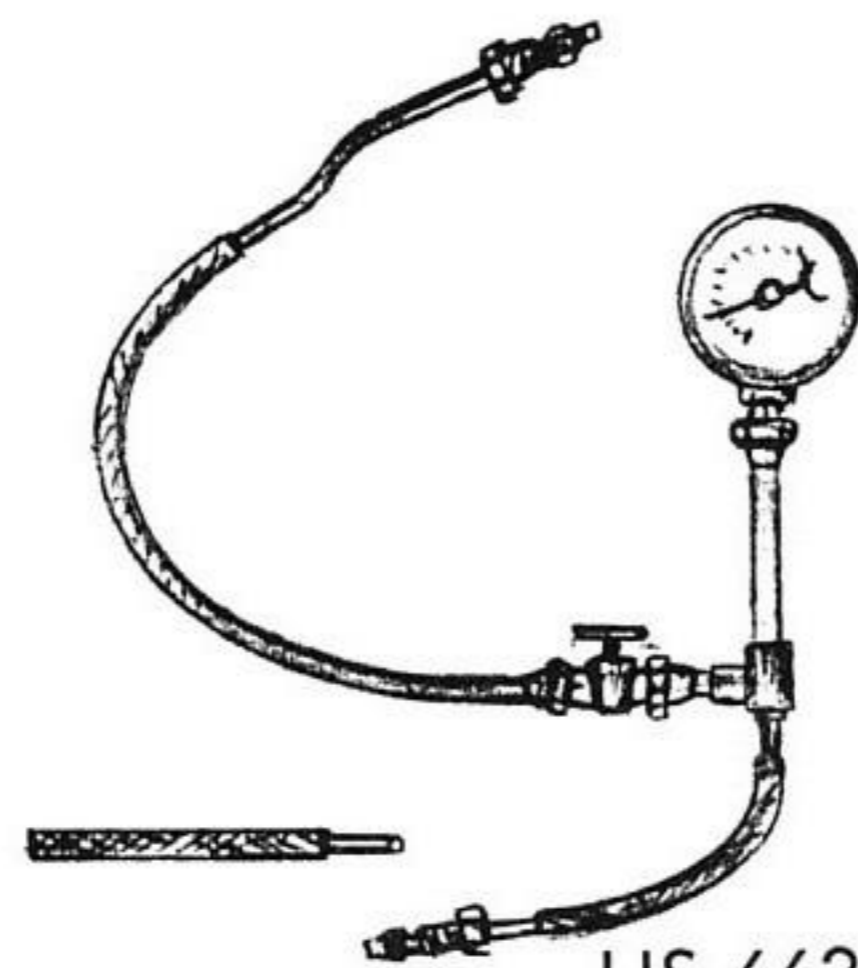

US 663-1

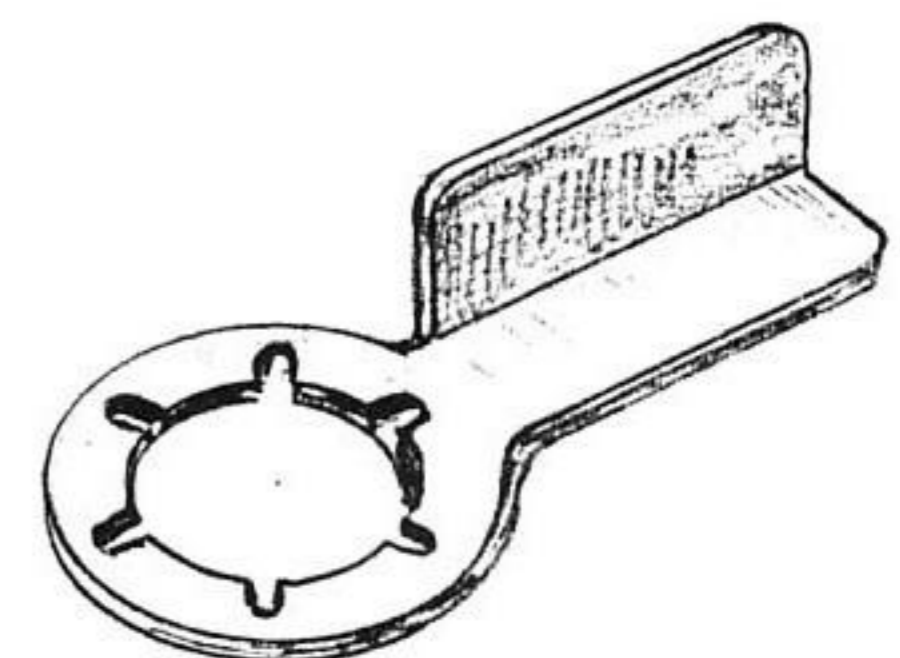

US 664

Special TOOLS

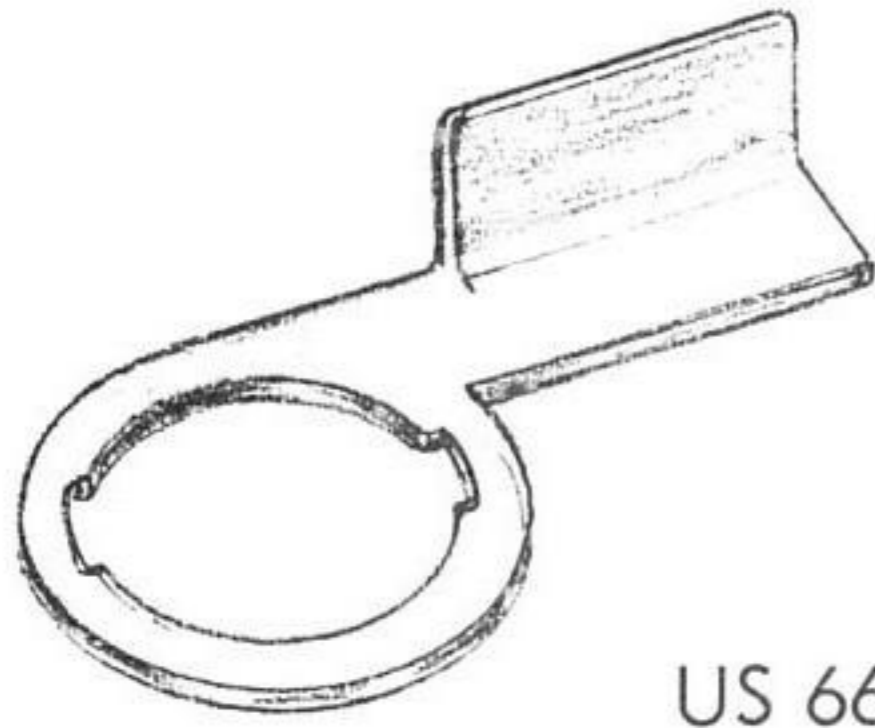

US 664-I

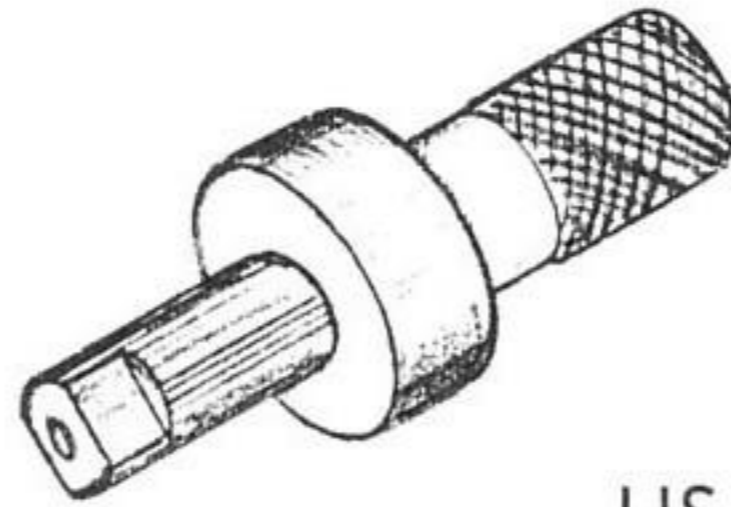

US 665

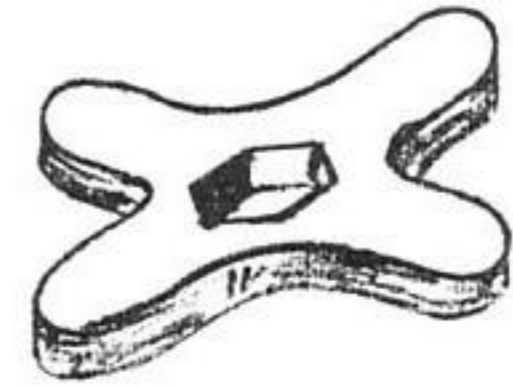

US 667

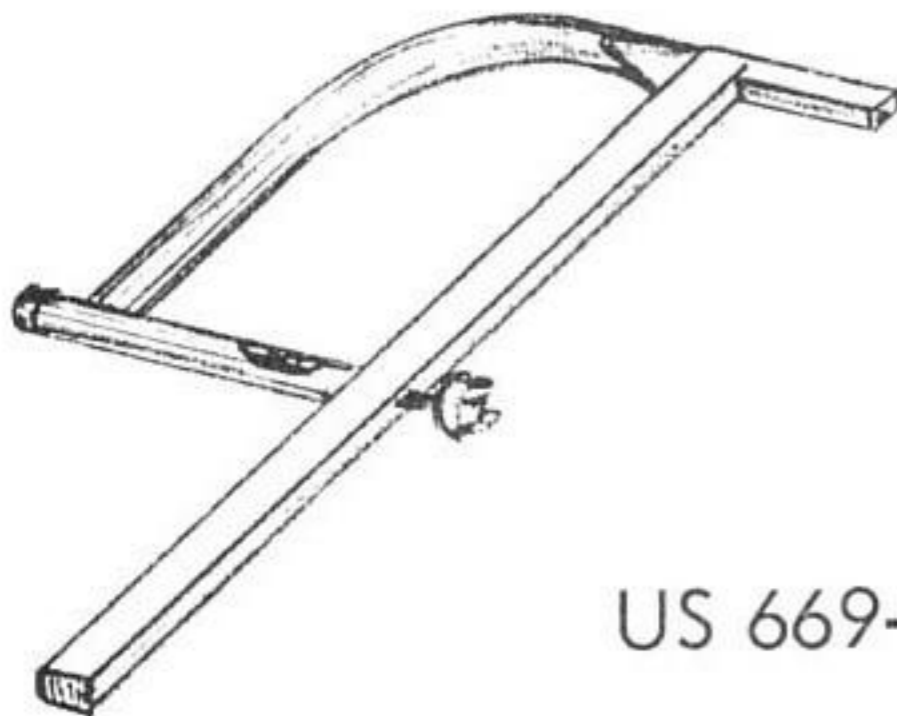

US 669-I

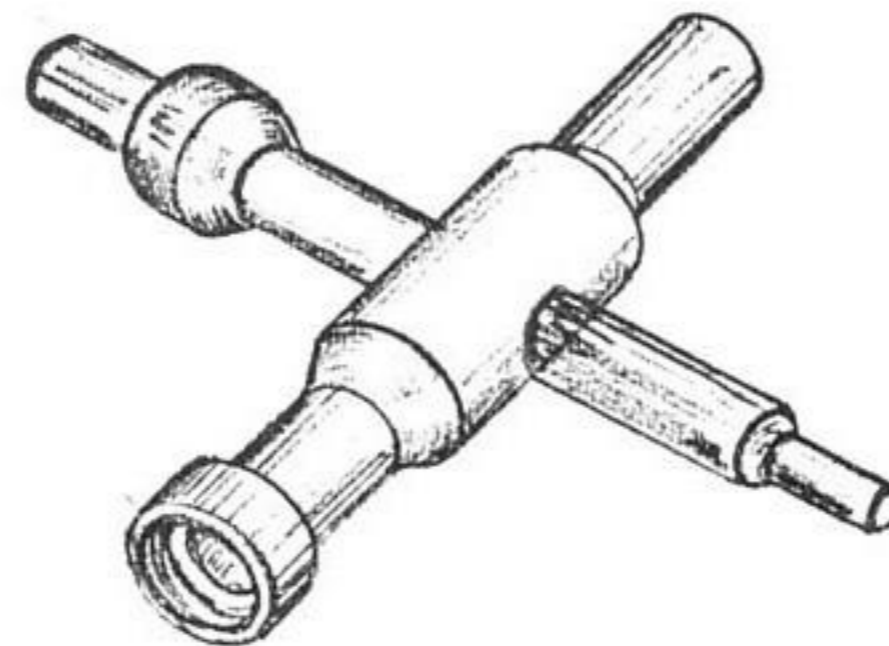

US 674 A

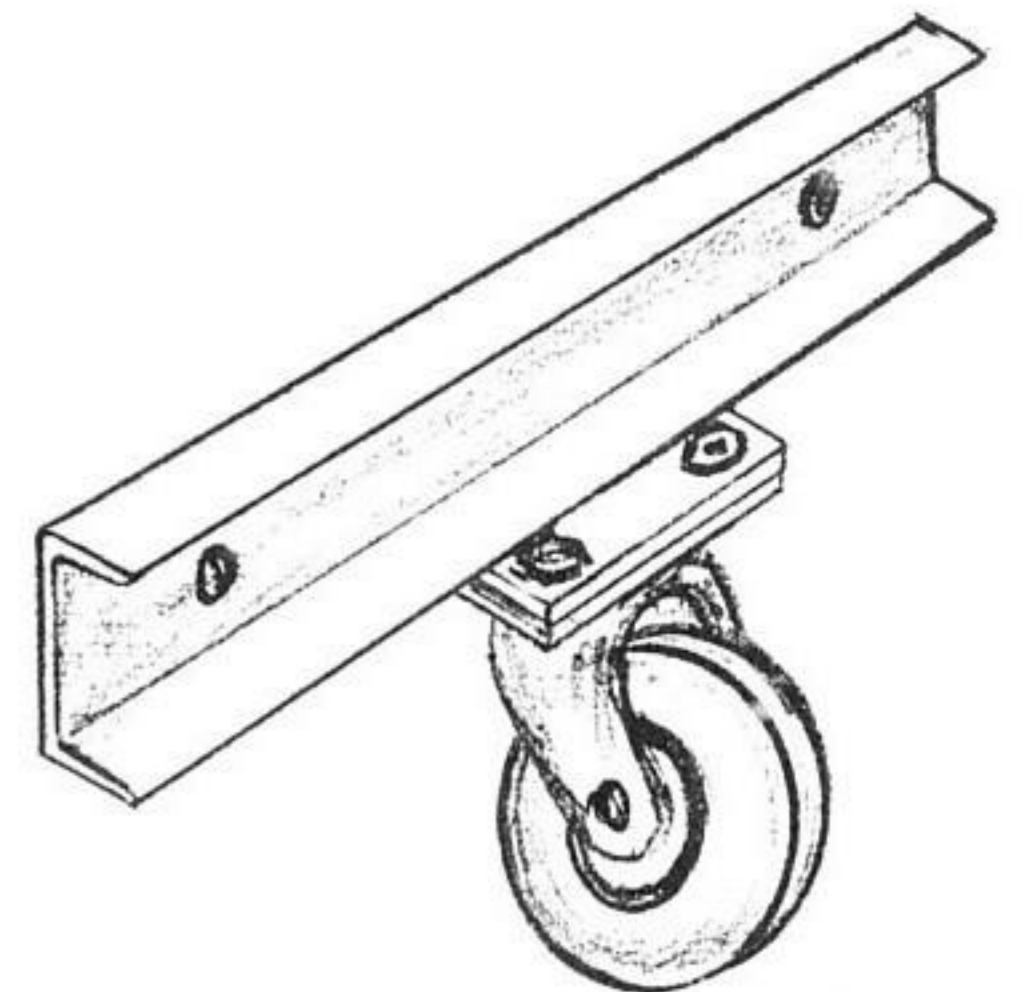

US 676

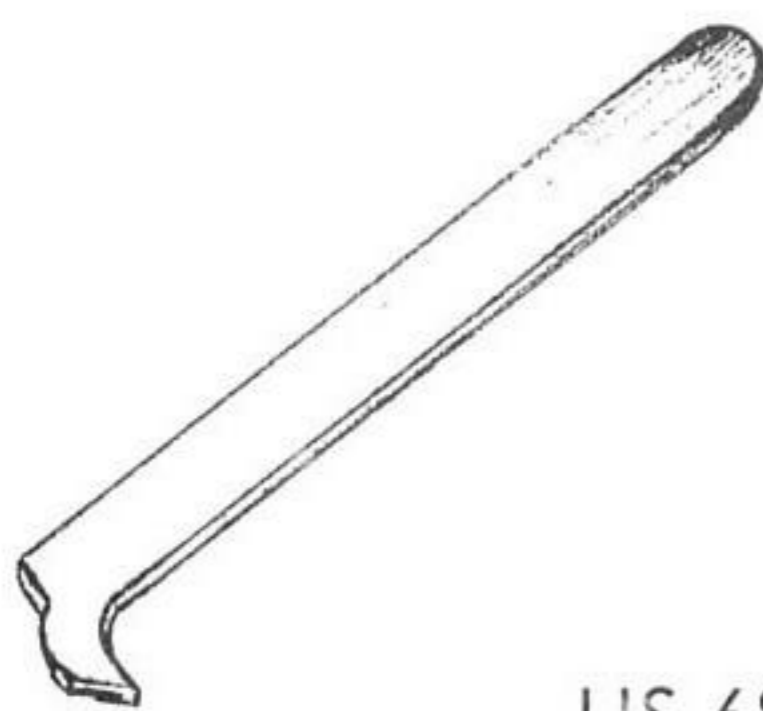

US 681

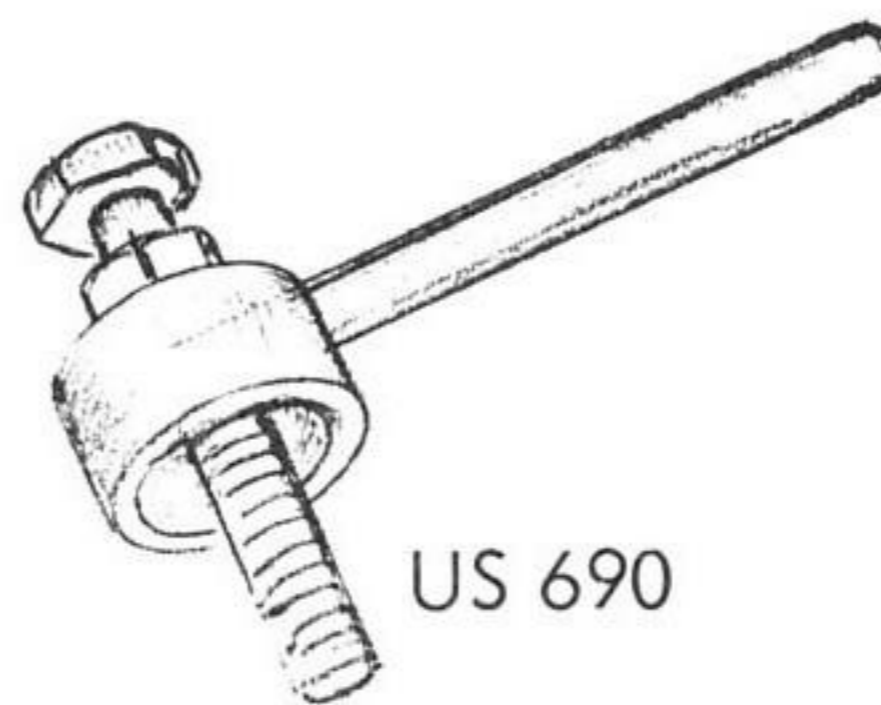

US 690

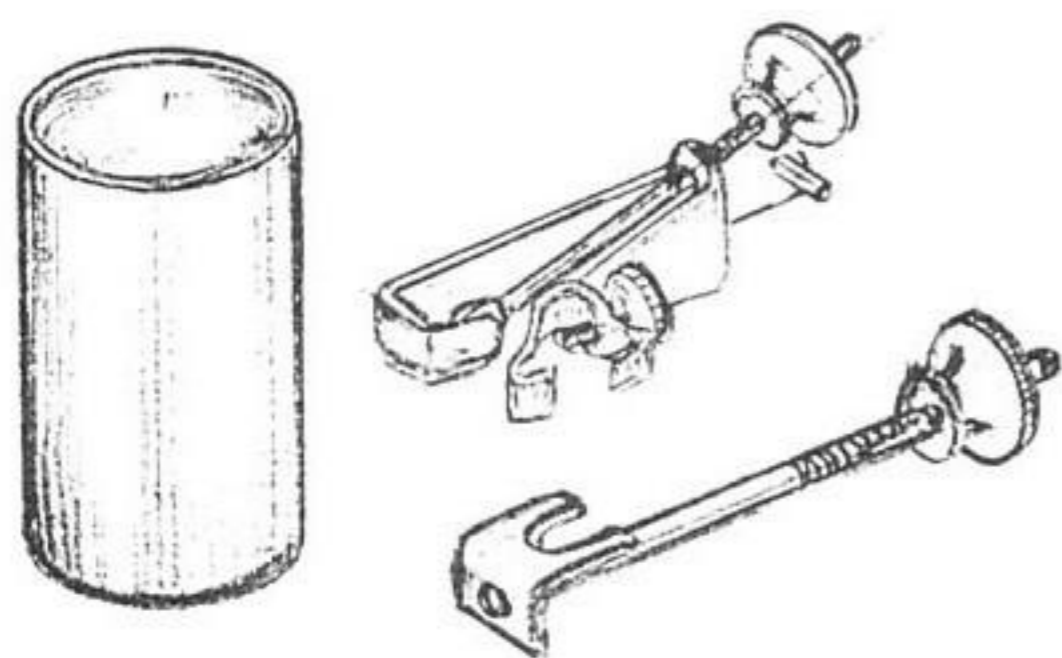

US 691



US 691-I

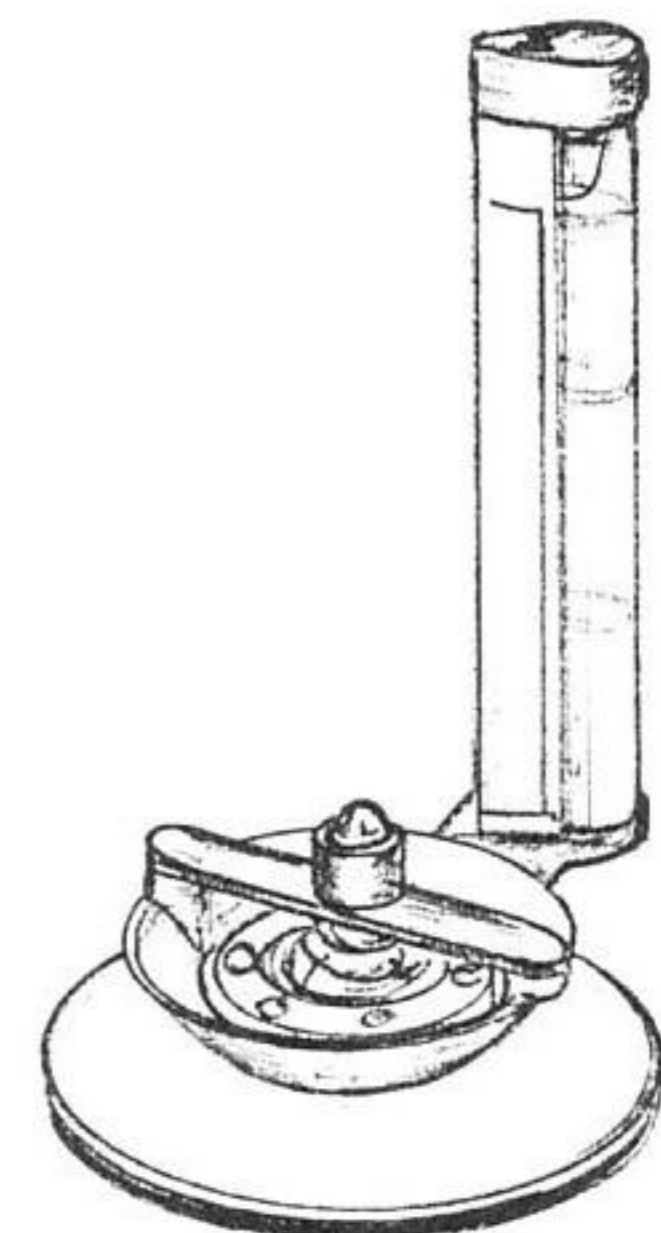

US 691 A

Special TOOLS

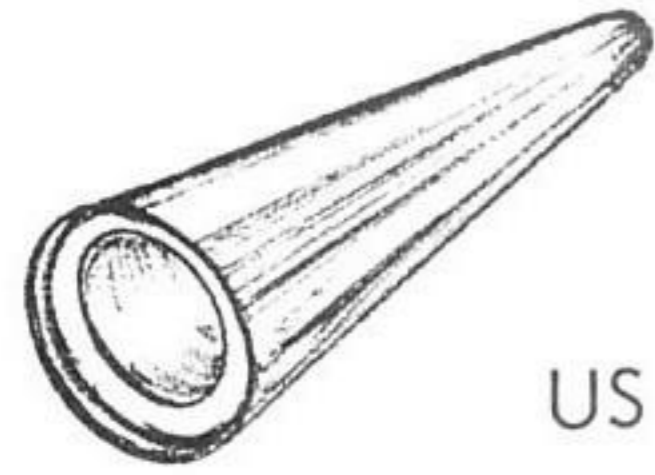

US 692

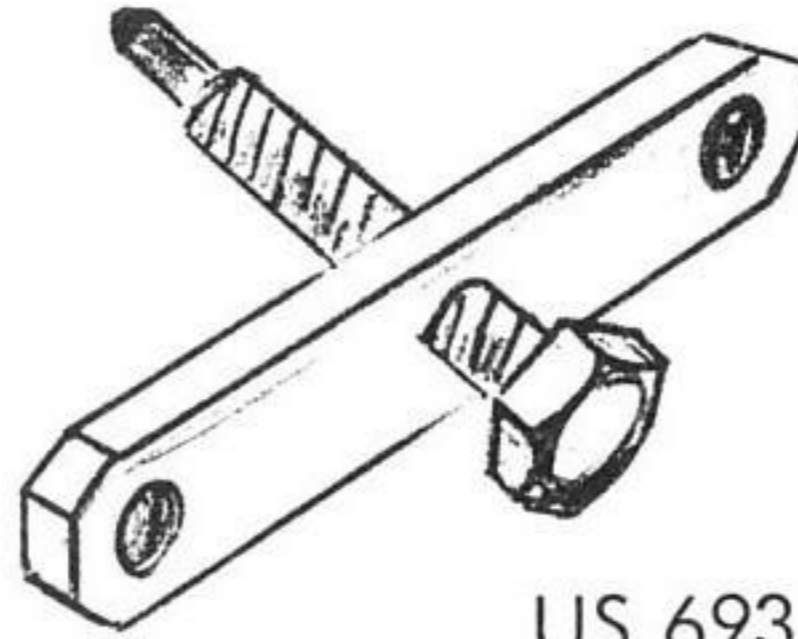

US 693

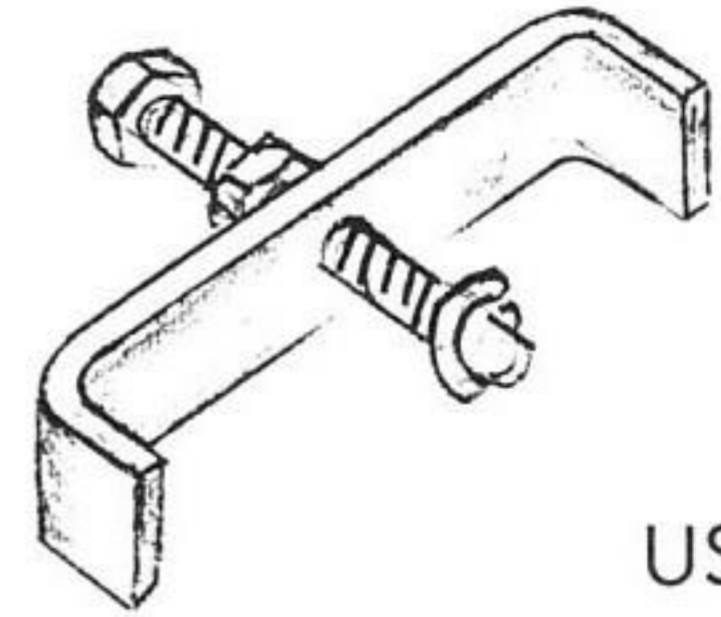

US 694

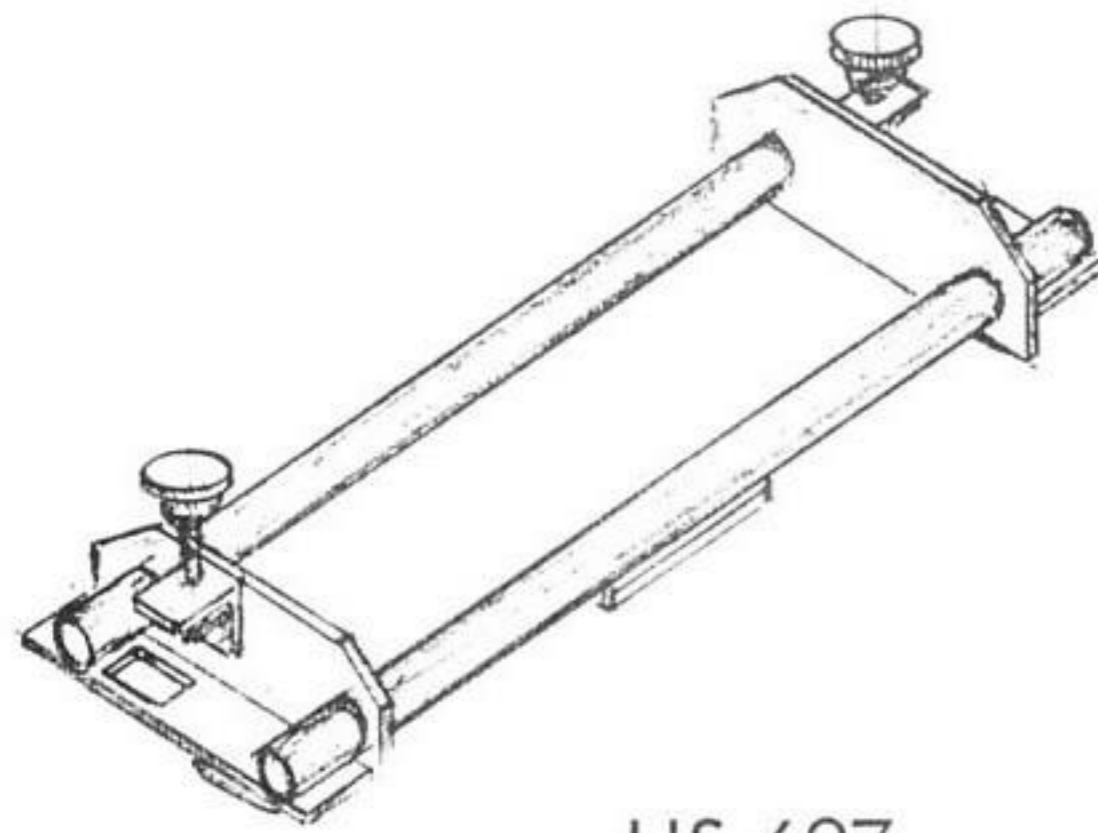

US 697

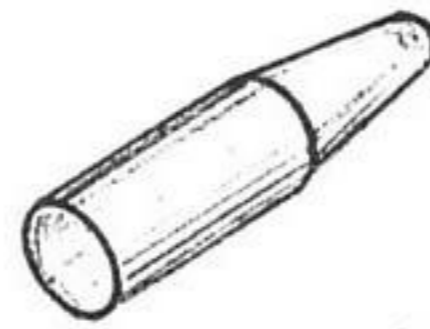

US 699

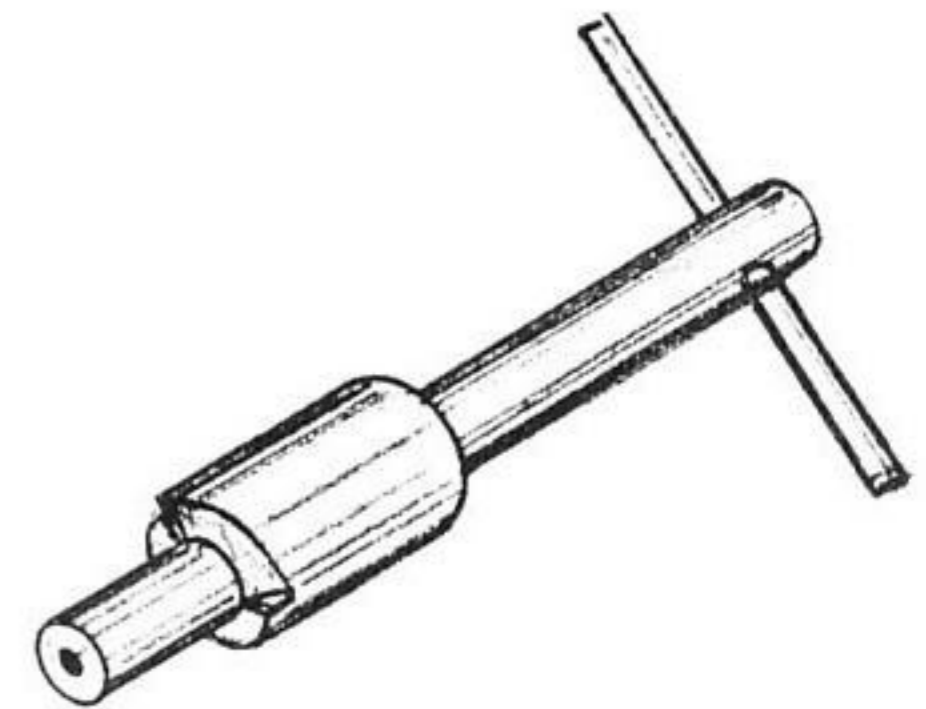

US 699-64

Special **TOOLS**

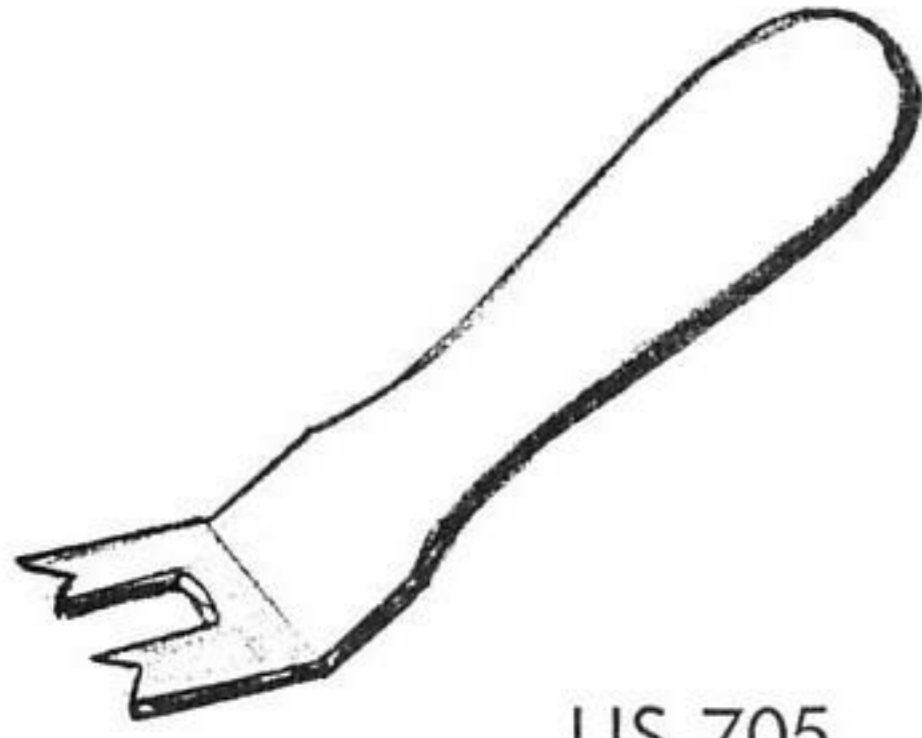

US 705

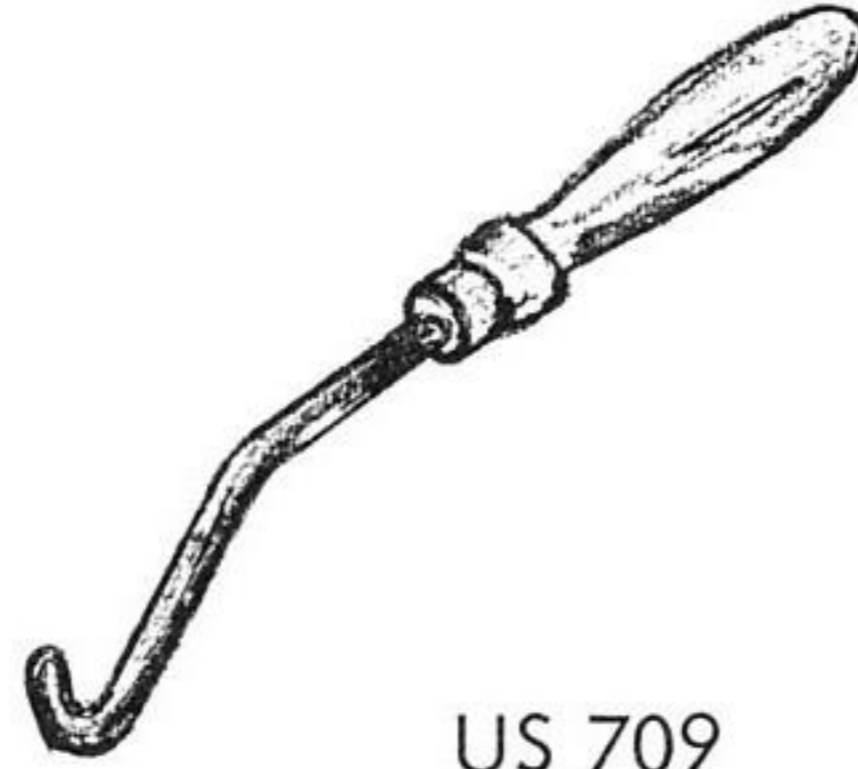

US 709

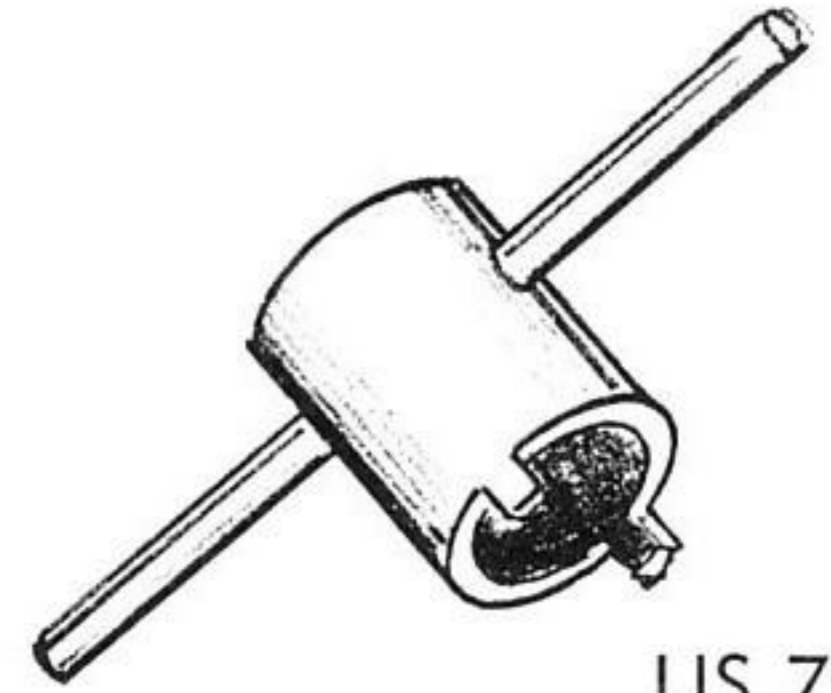

US 710

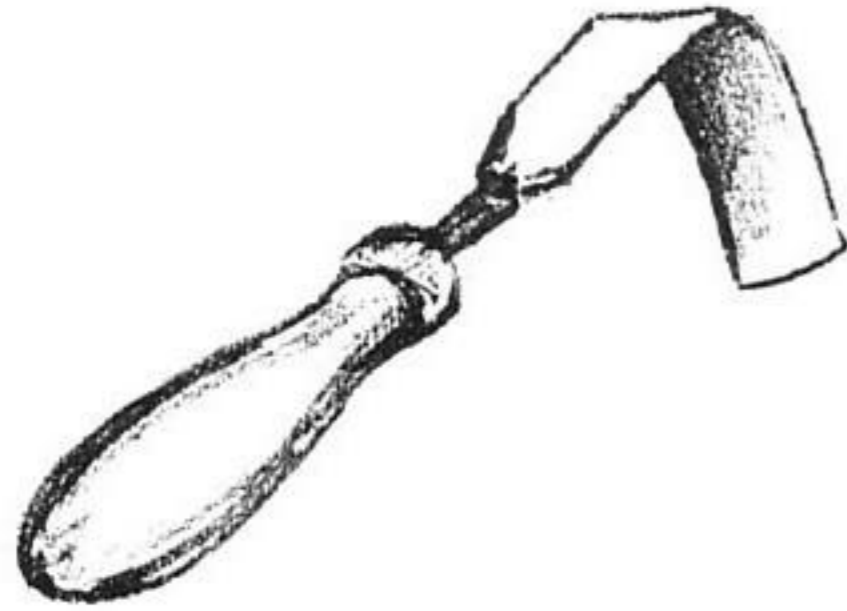

US 736-I

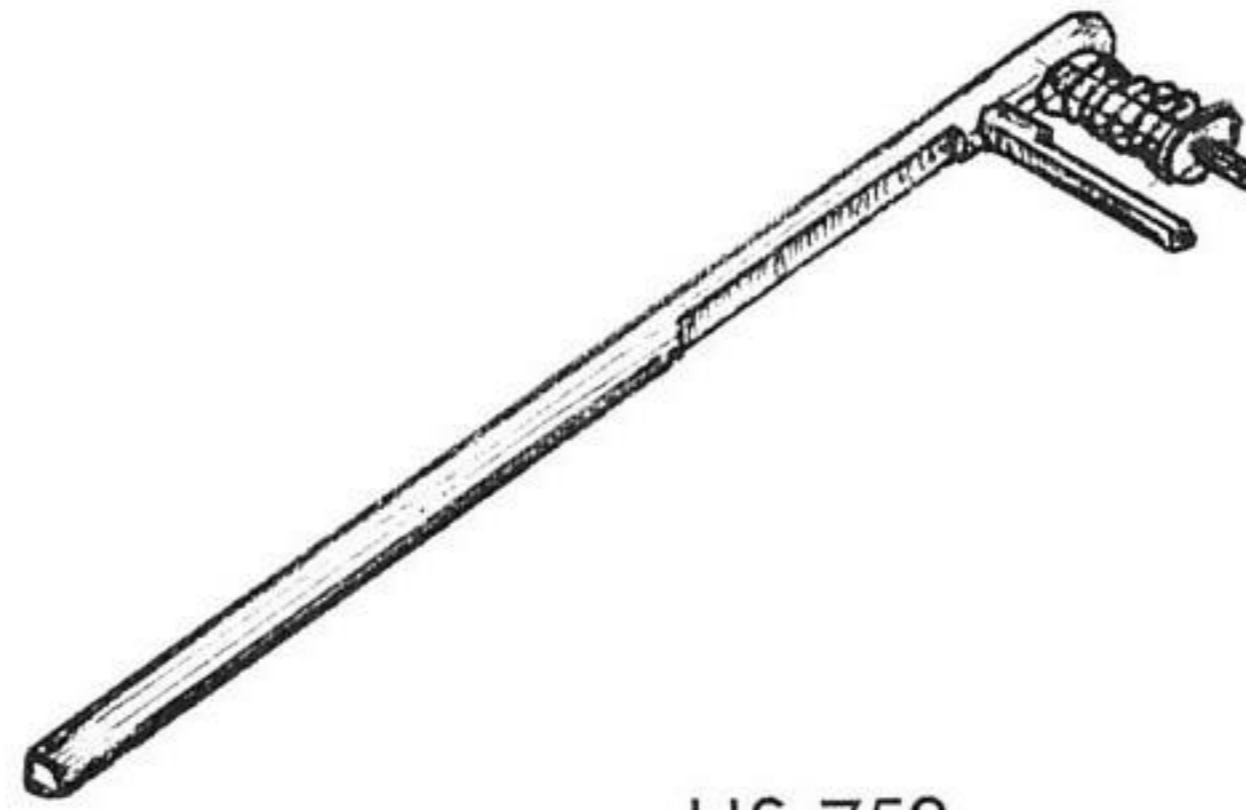

US 753

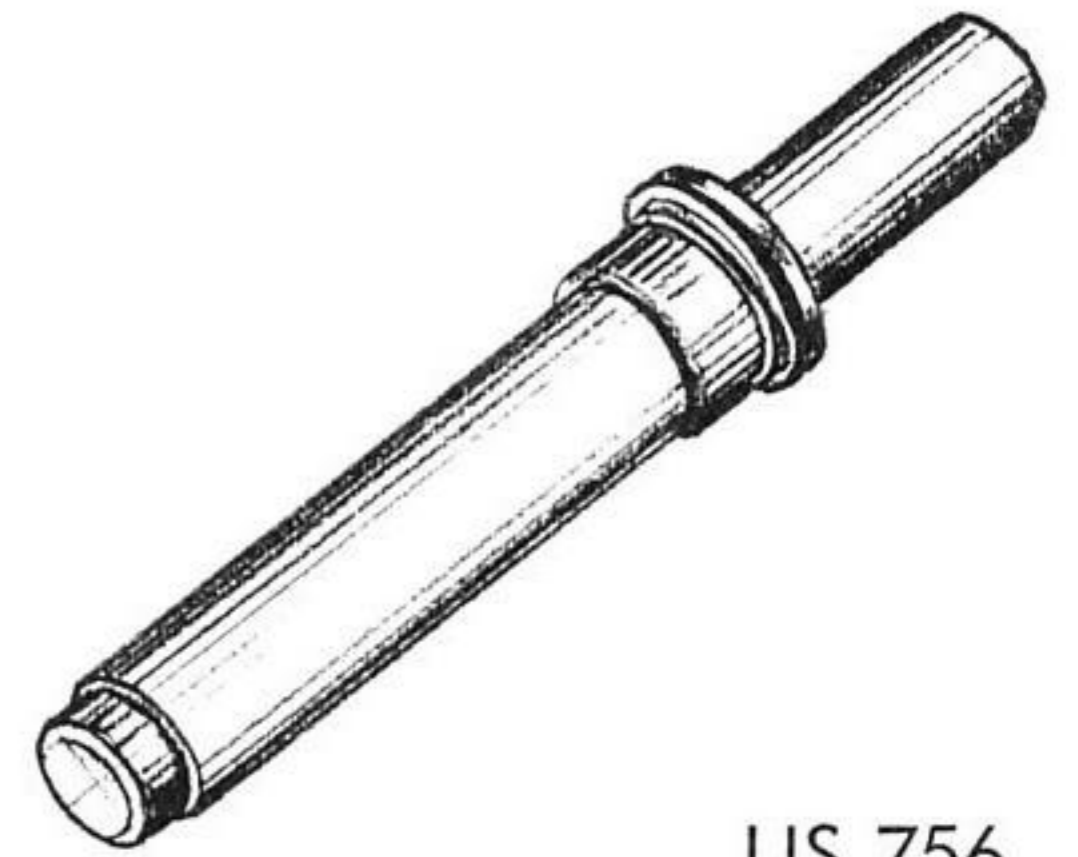

US 756

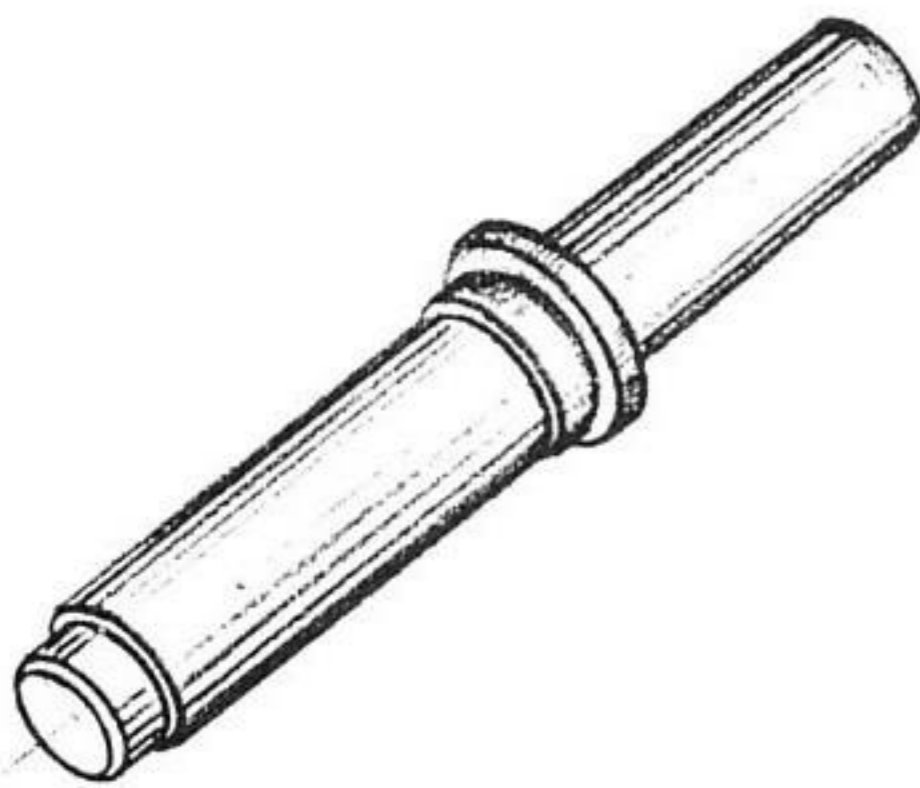

US 757

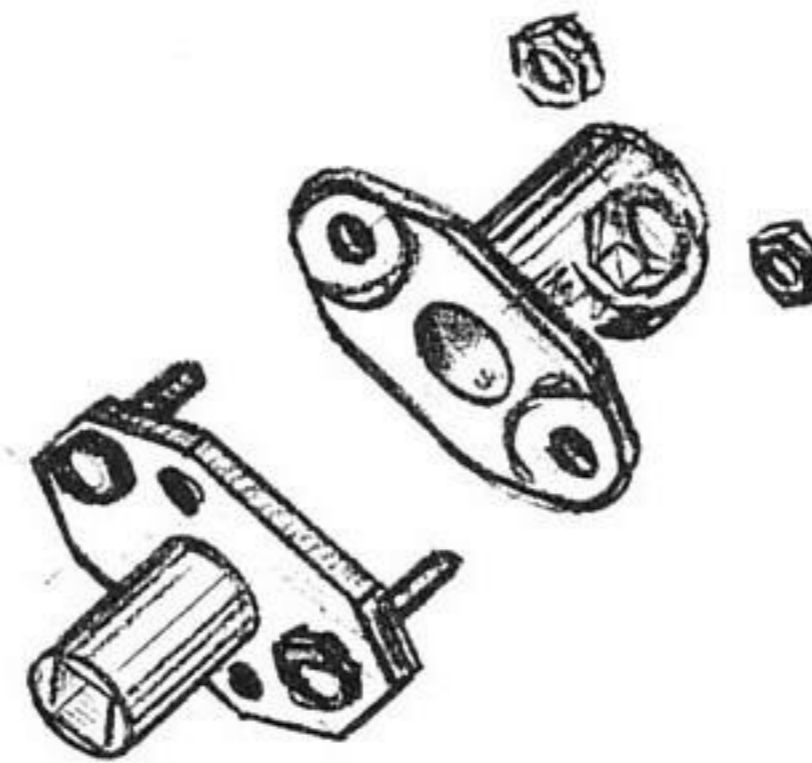

US 758-I

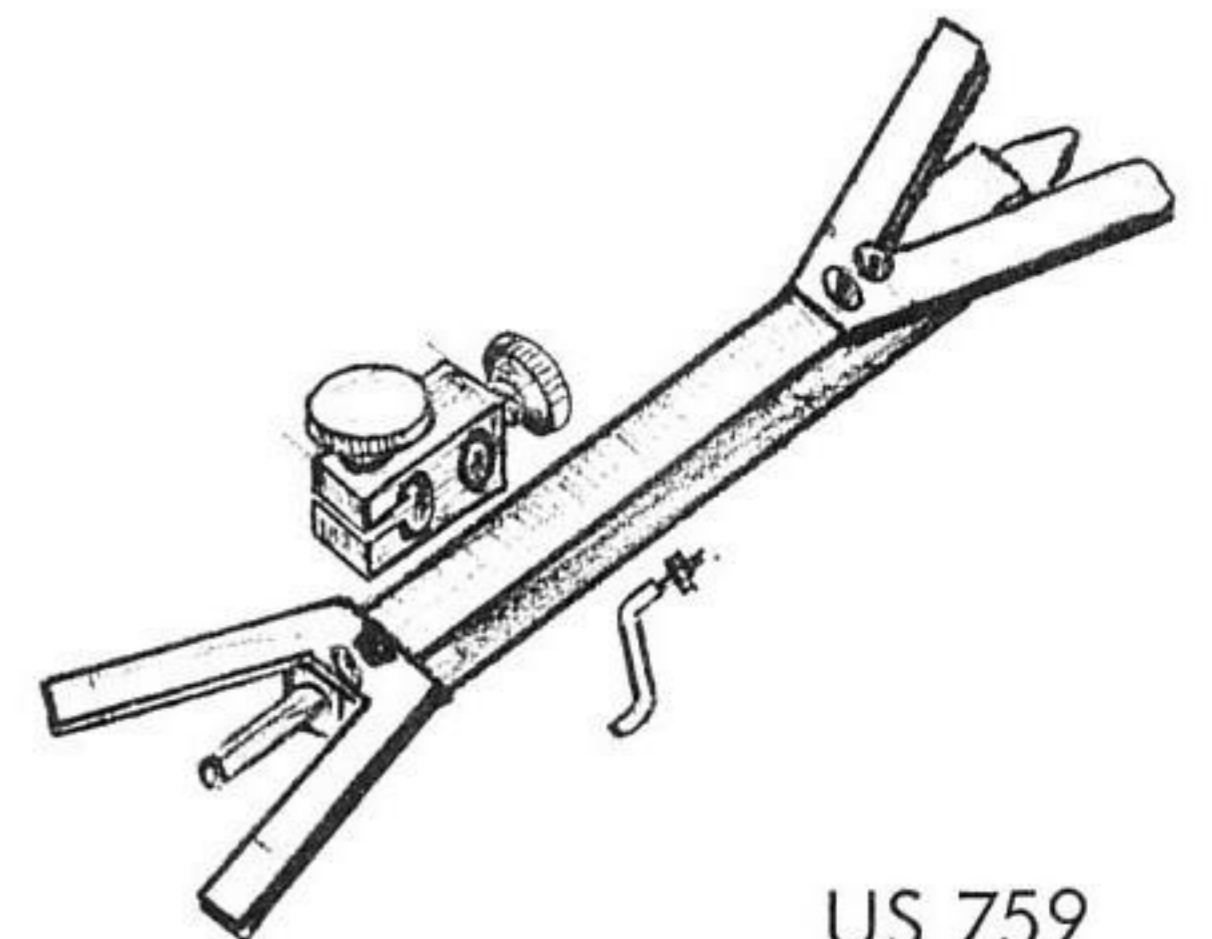

US 759

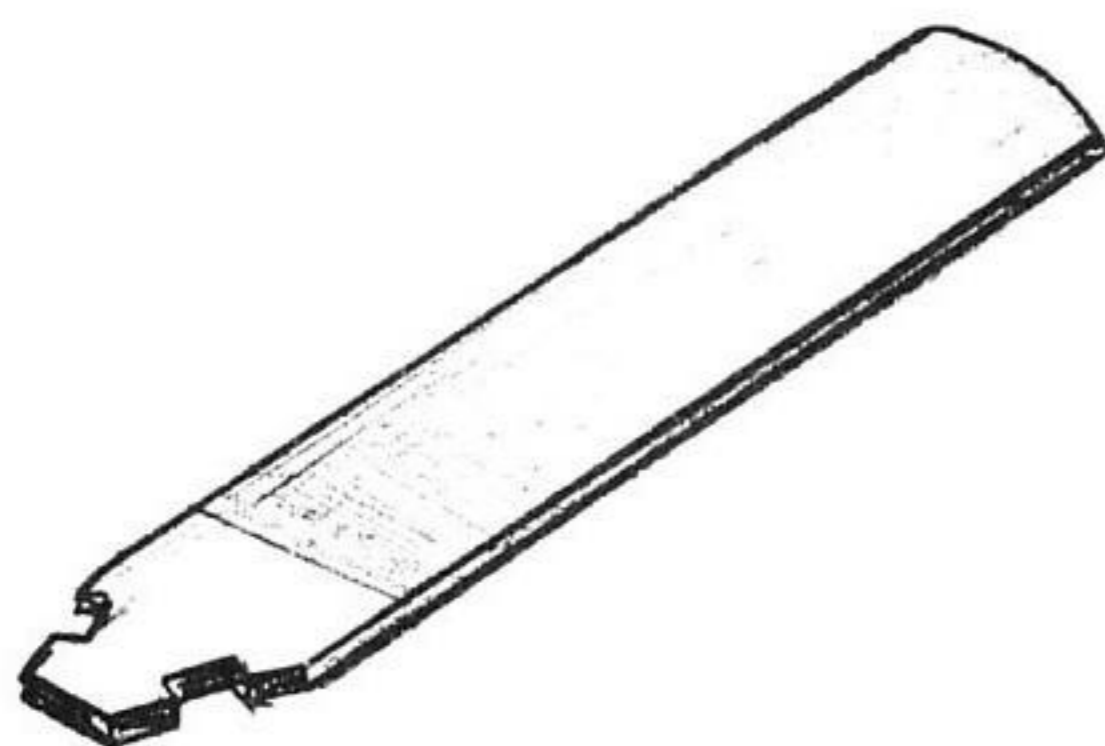

US 760

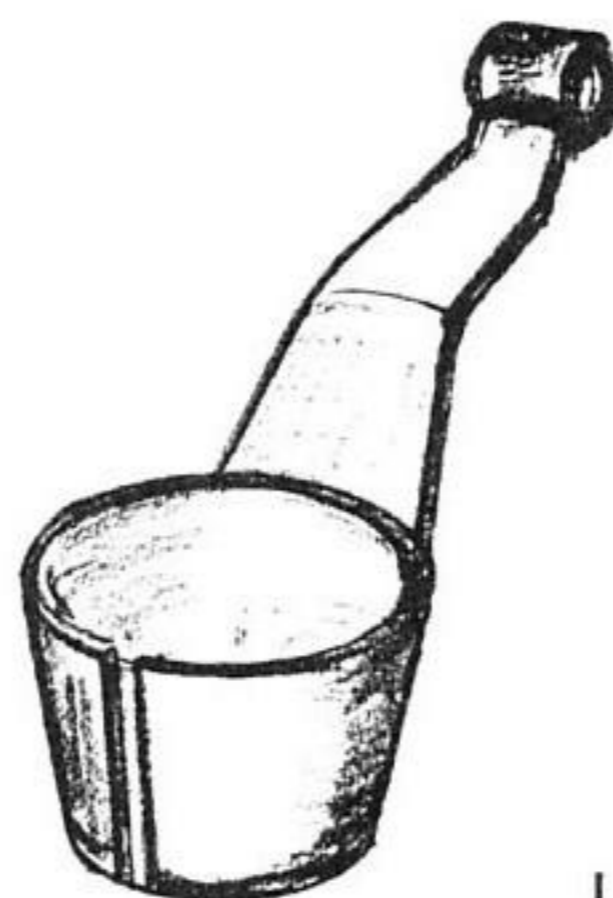

US 761

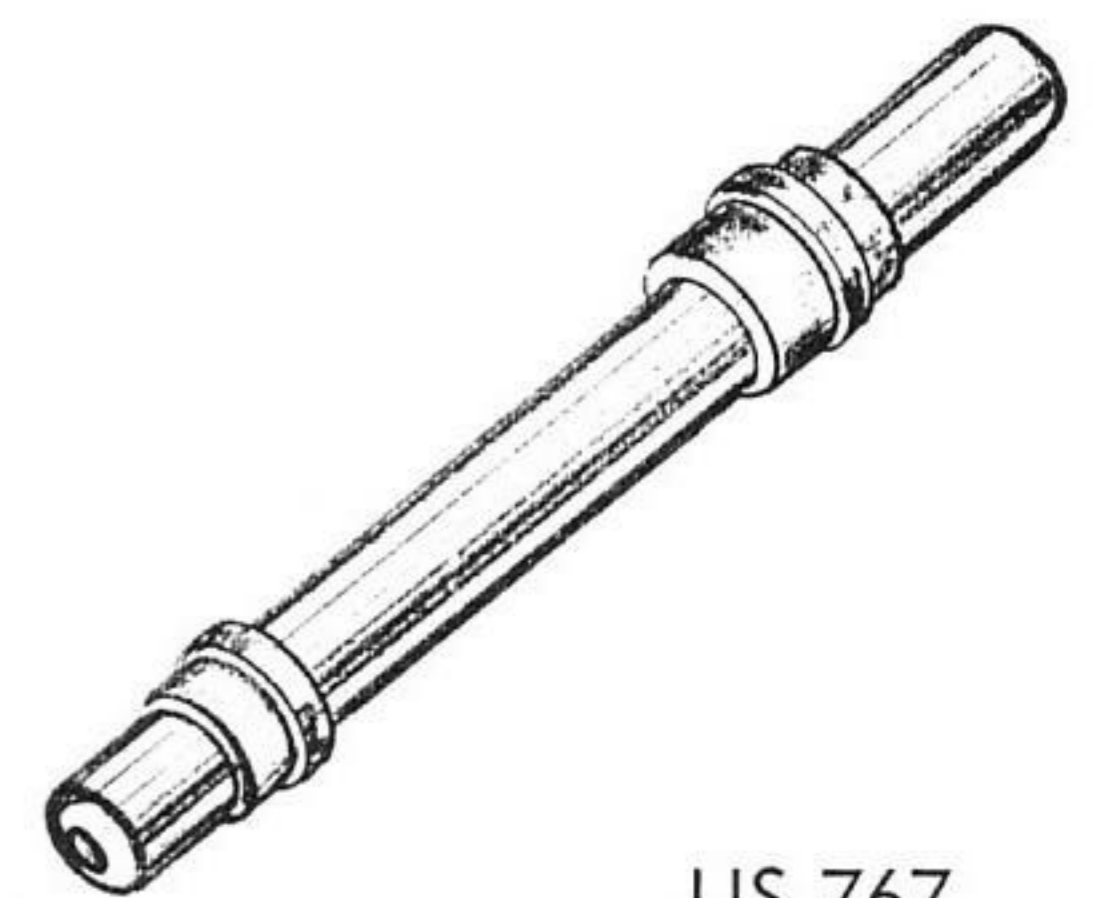

US 767

Special TOOLS

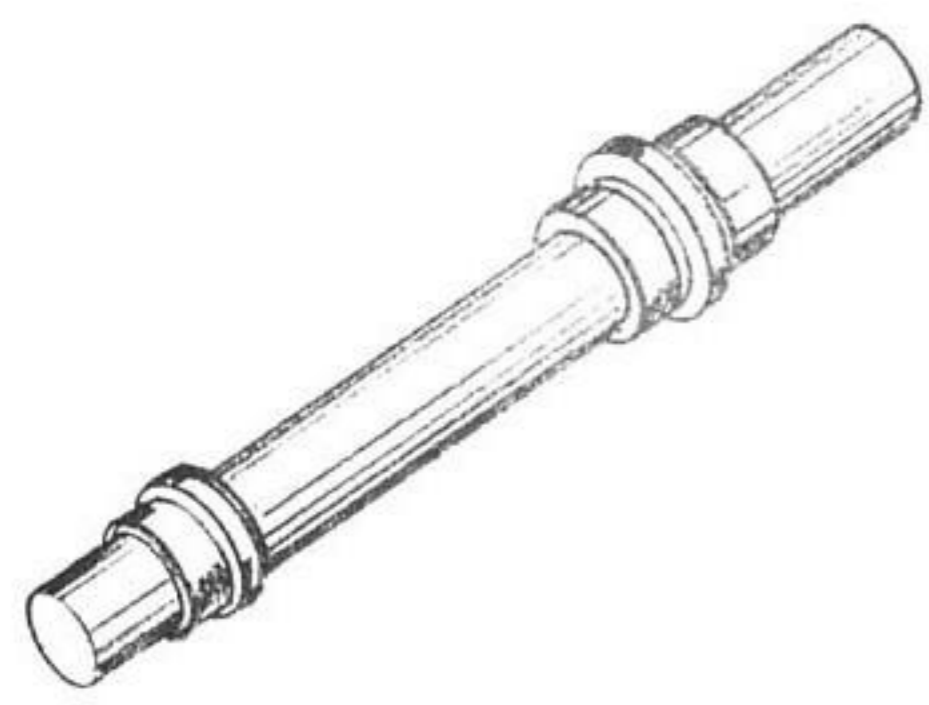

US 768

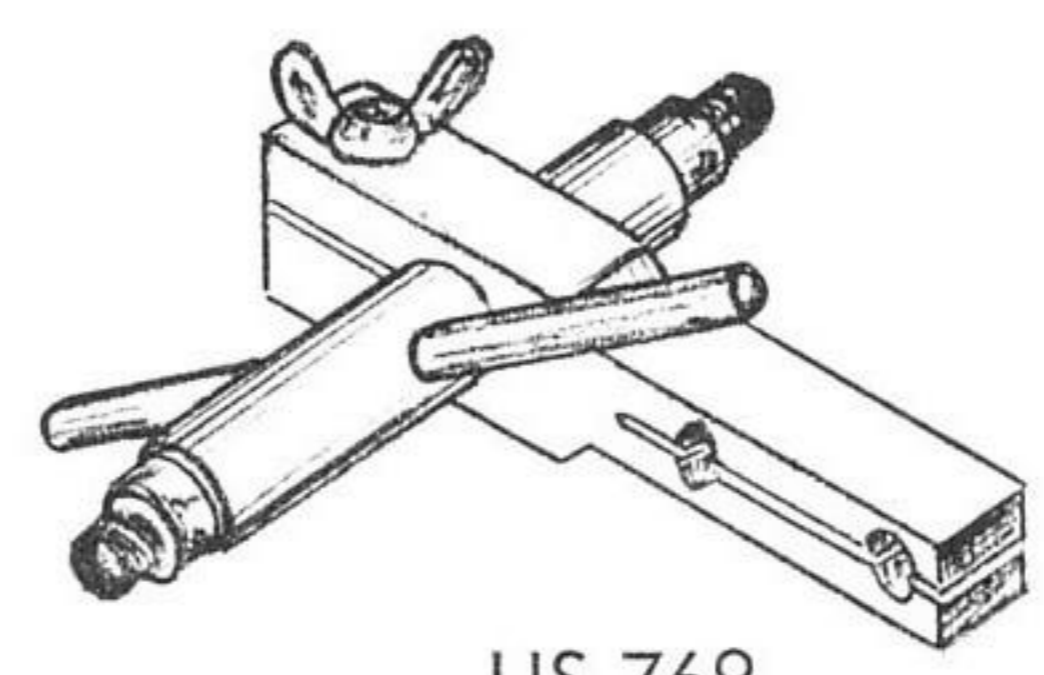

US 769

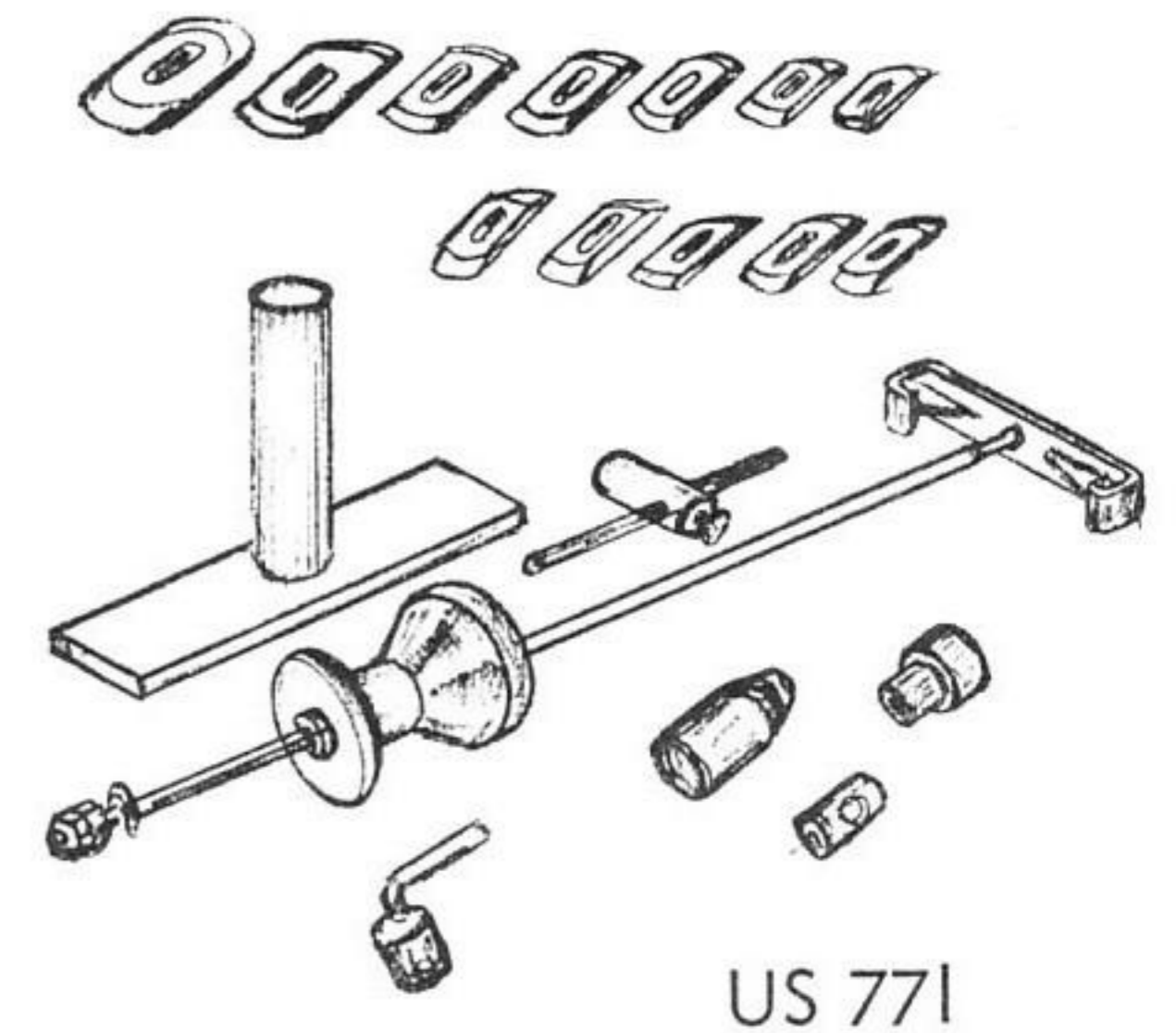

US 771

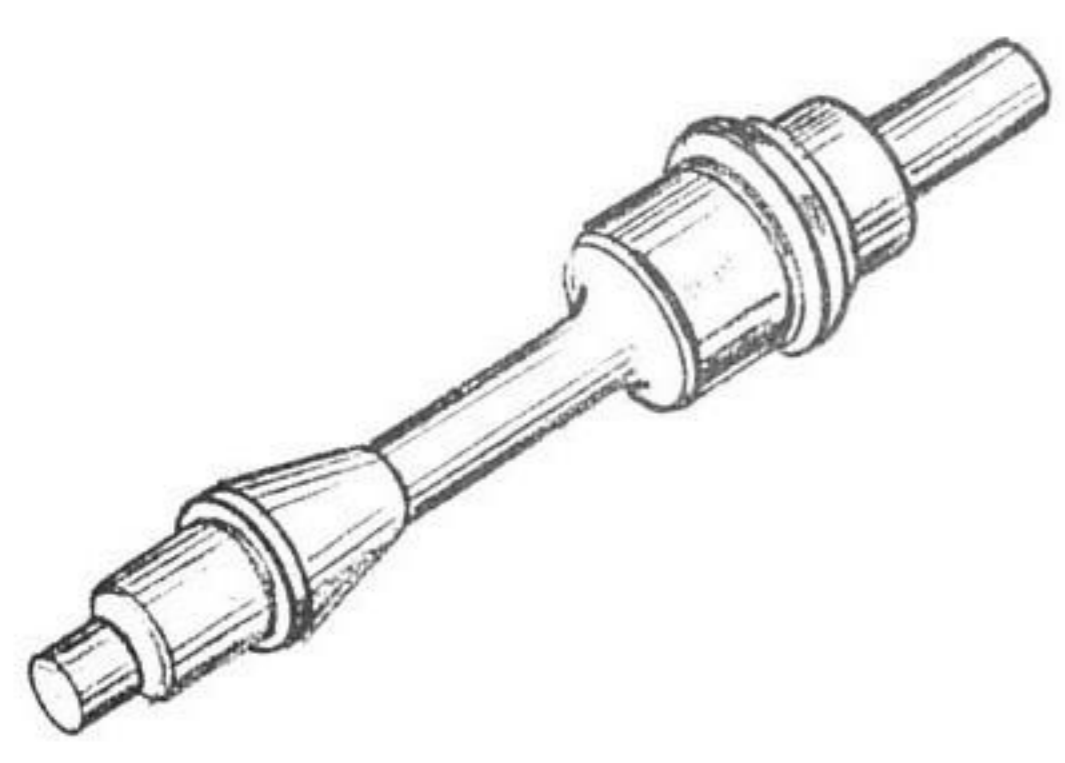

US 772

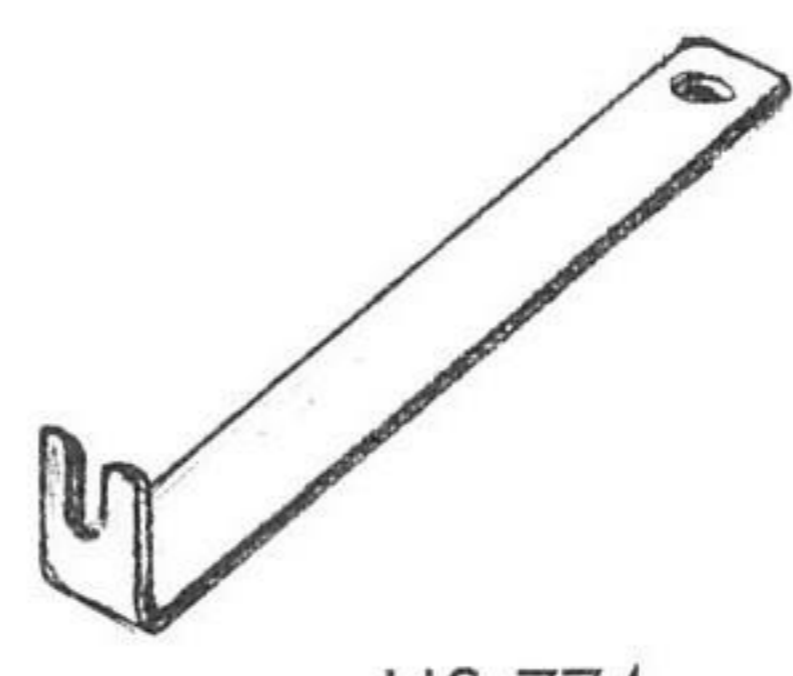

US 774



US 775

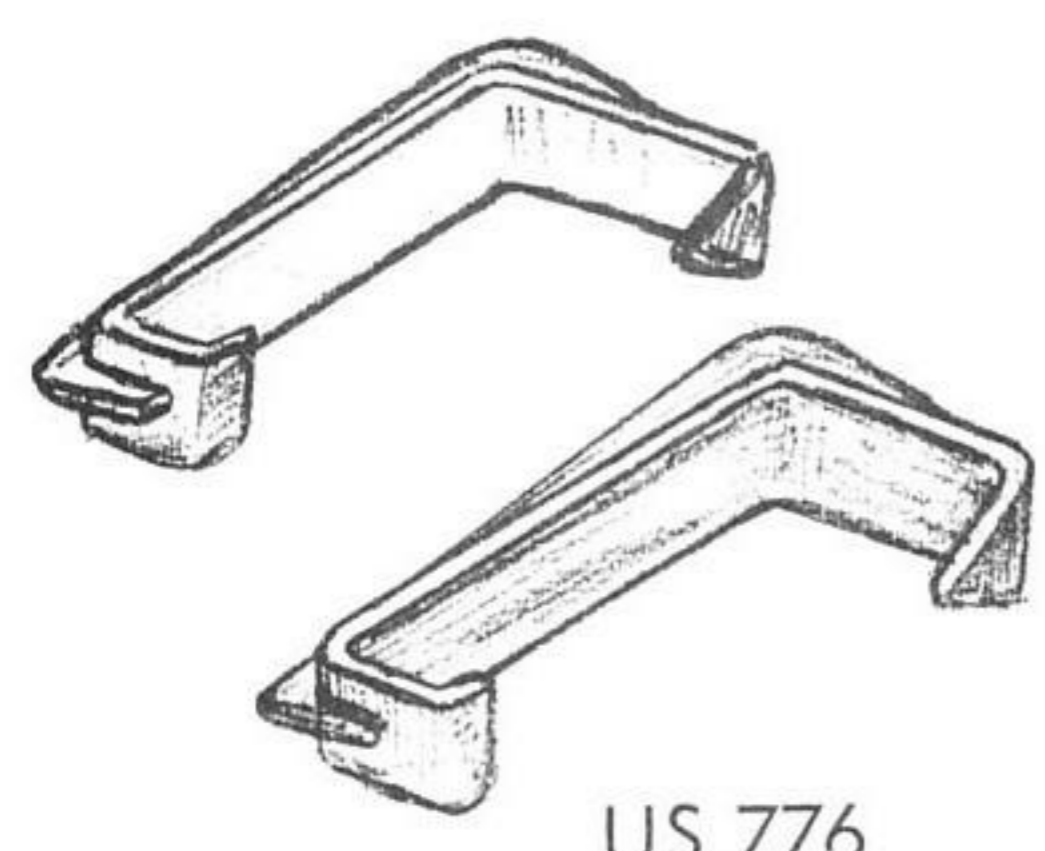

US 776

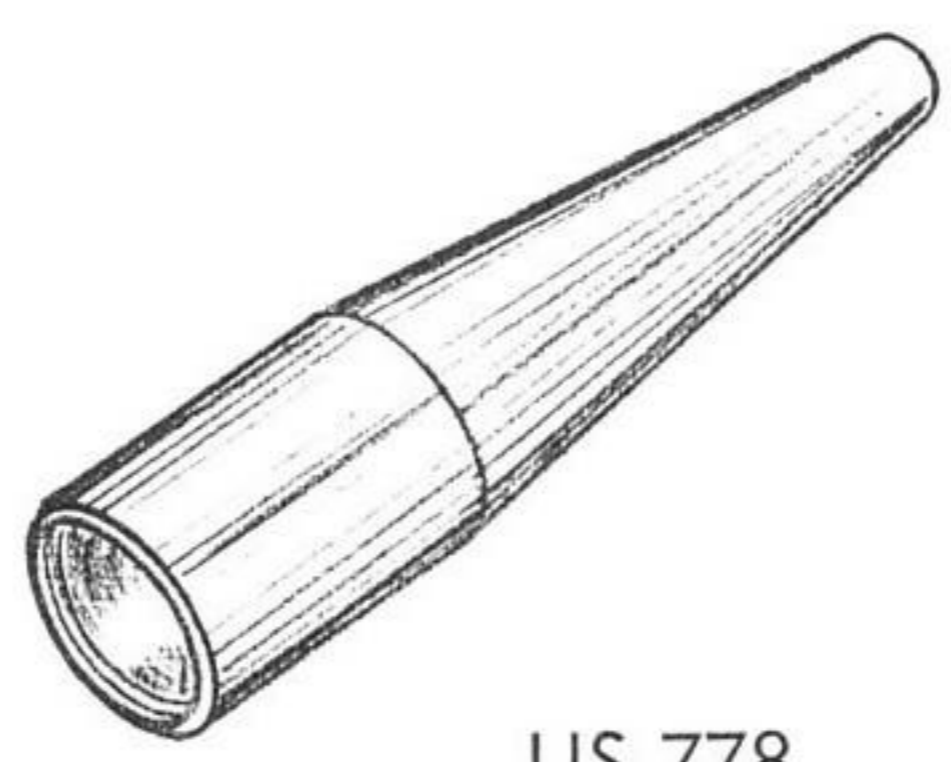

US 778

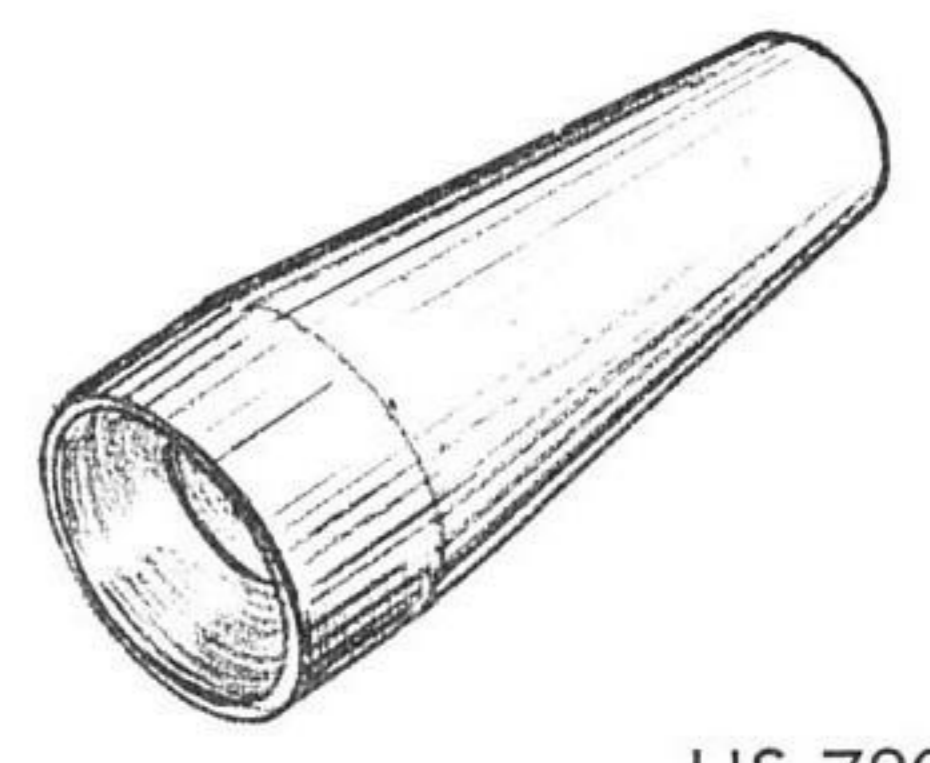

US 780-1

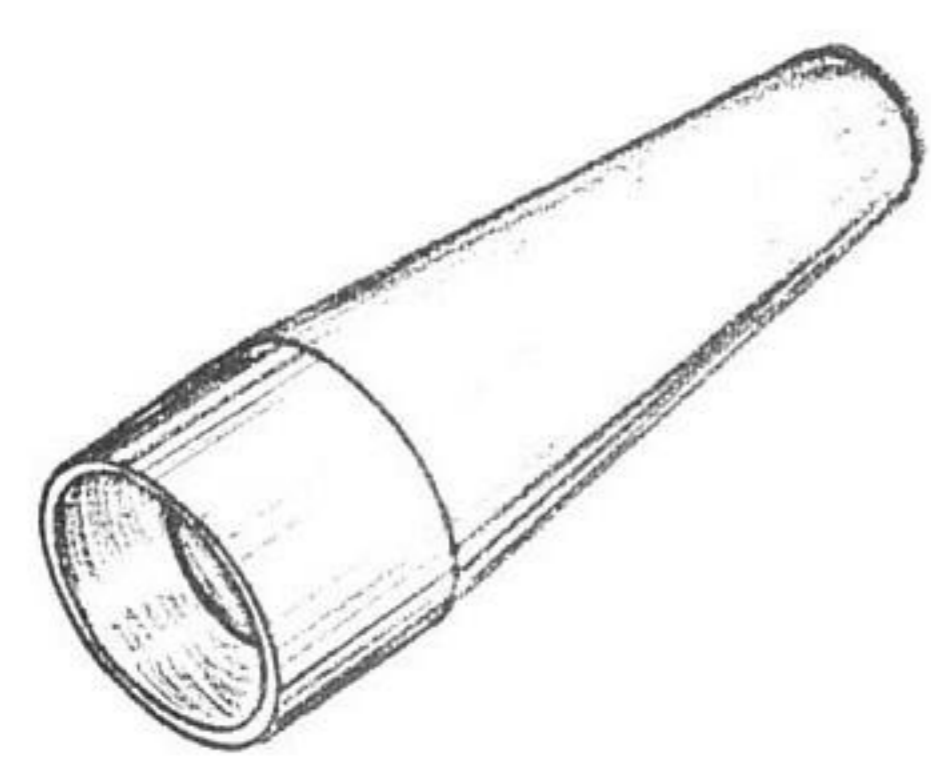

US 780-2

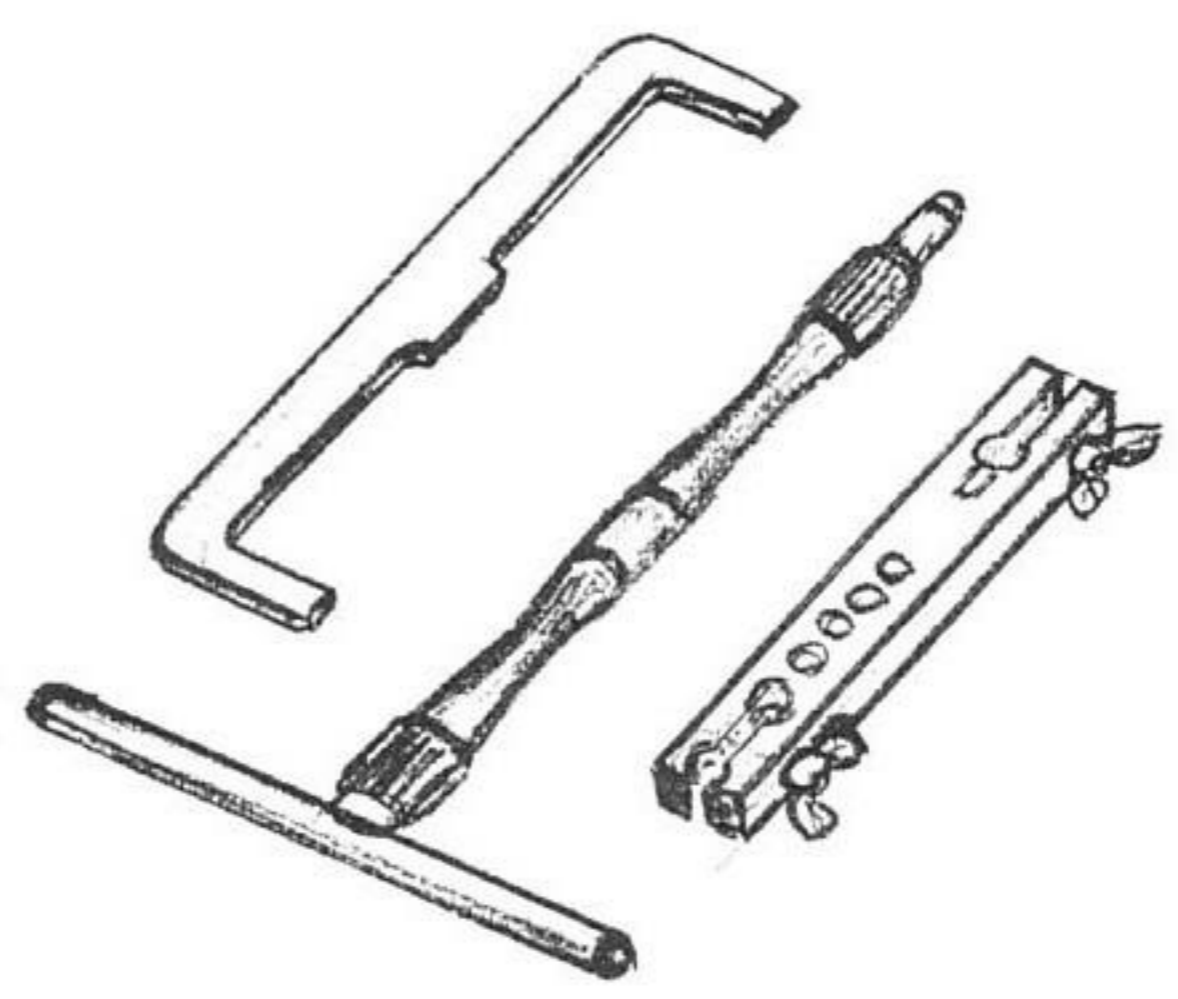

US 782

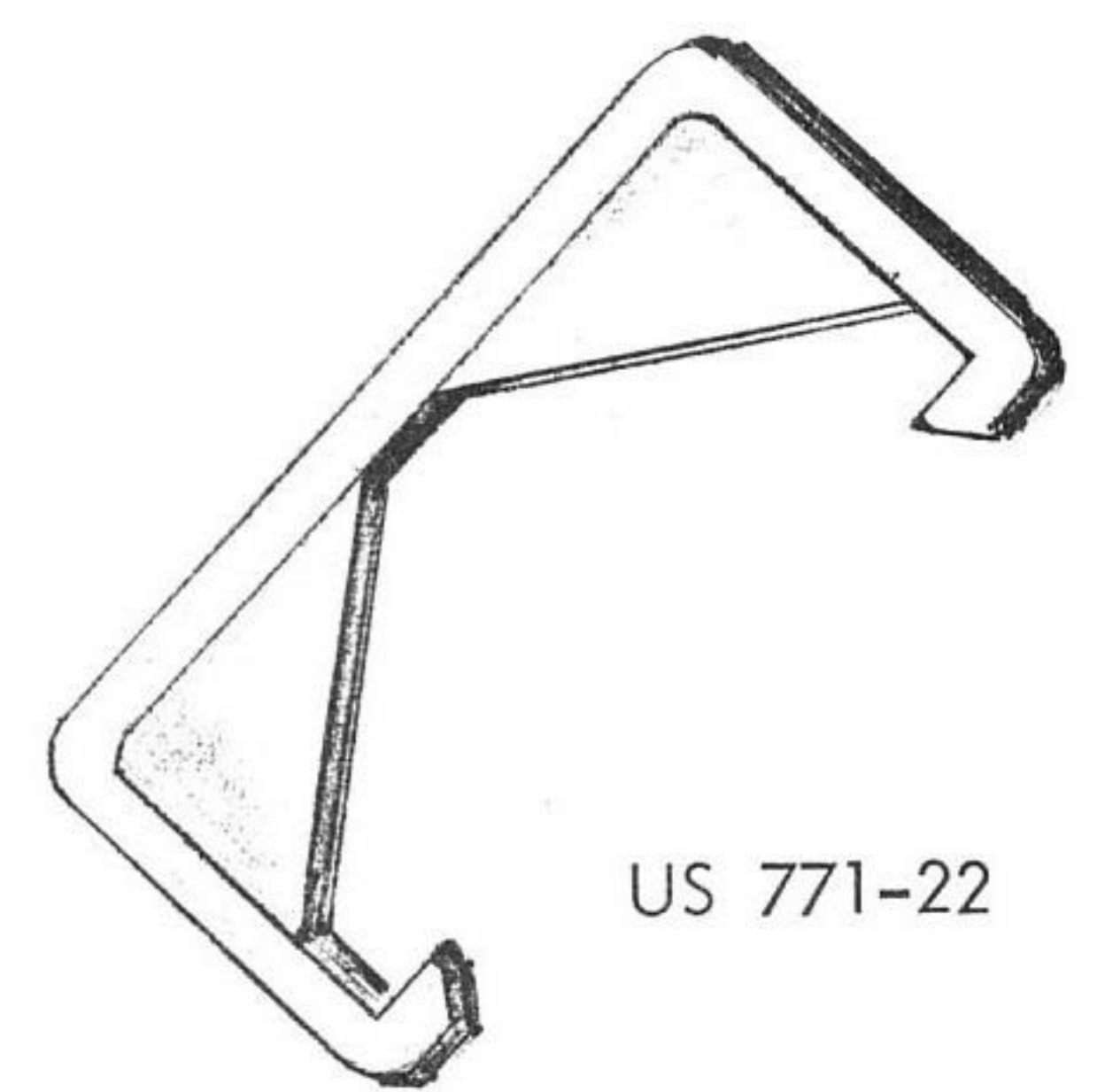

US 771-22

Special **TOOLS**

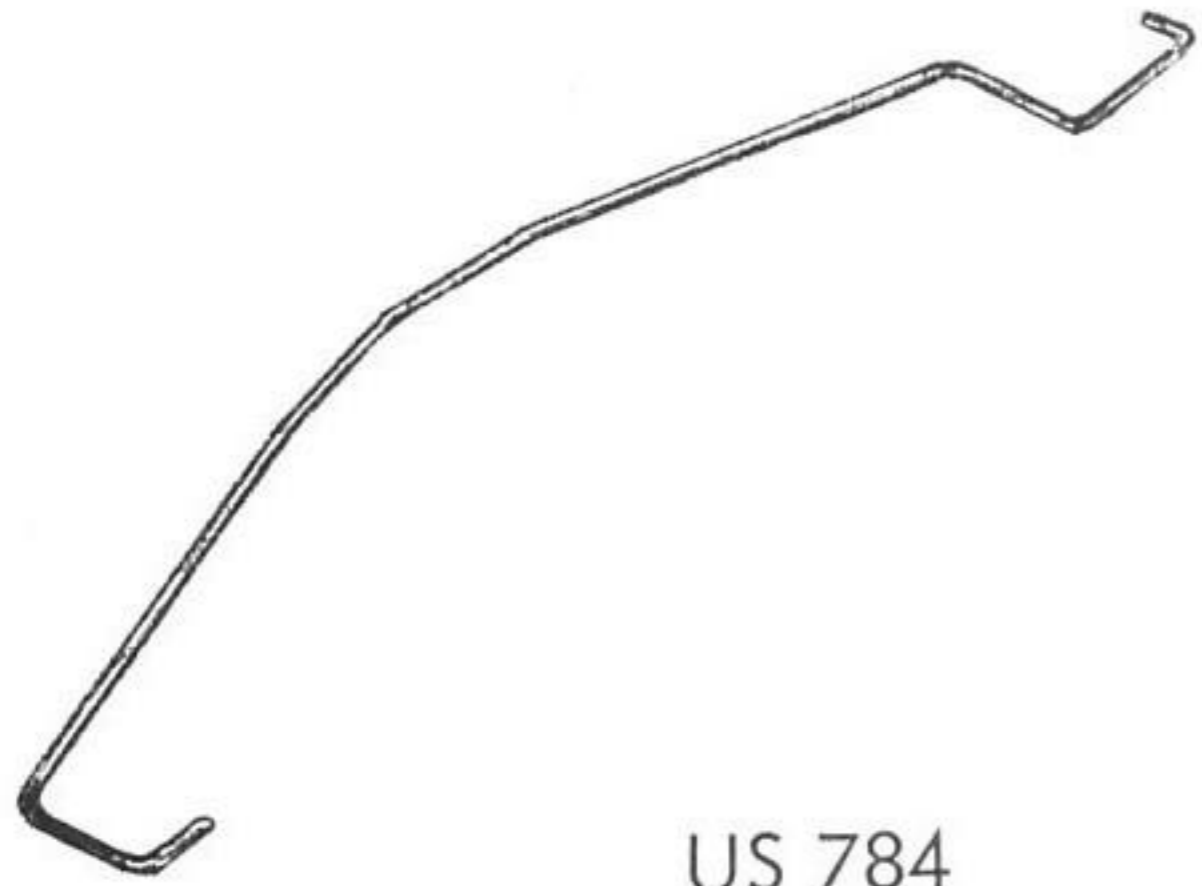

US 784

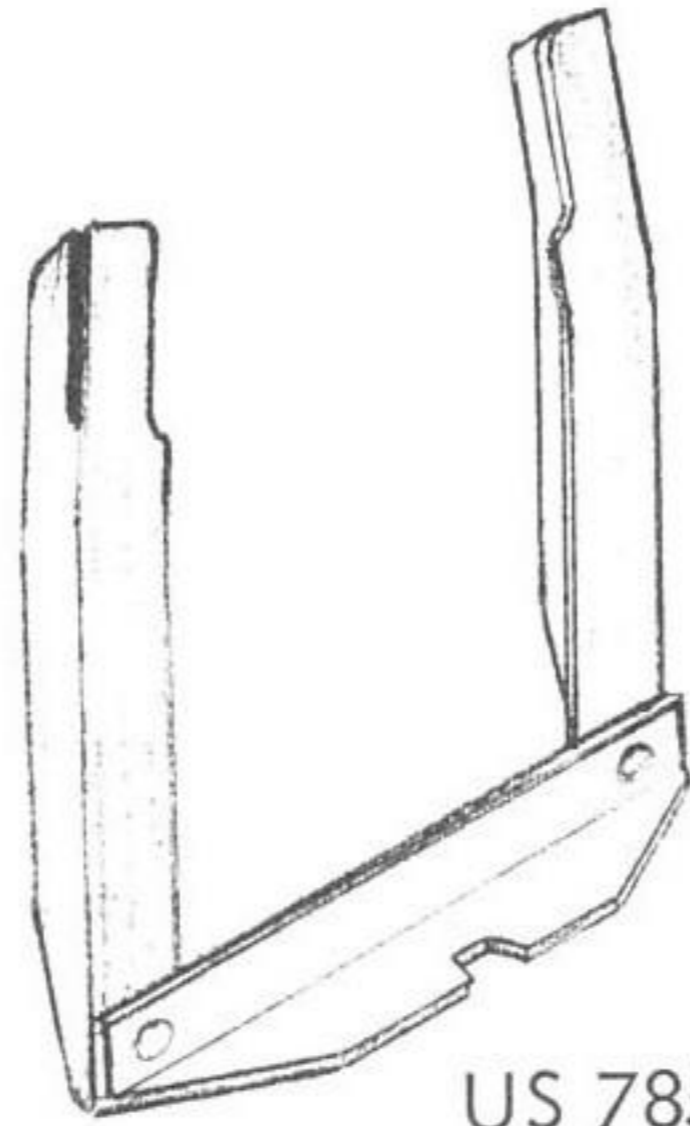

US 785

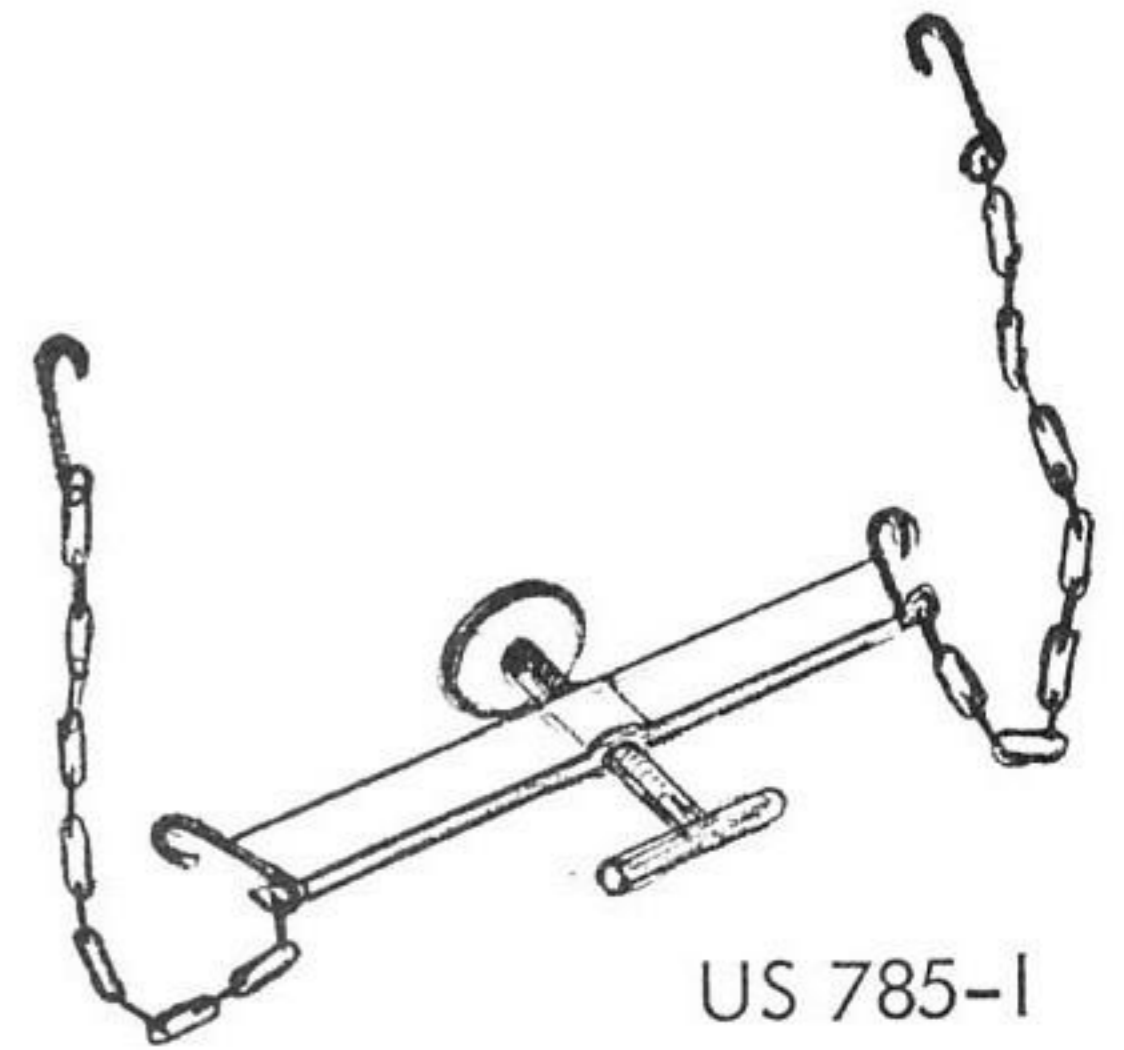

US 785-I

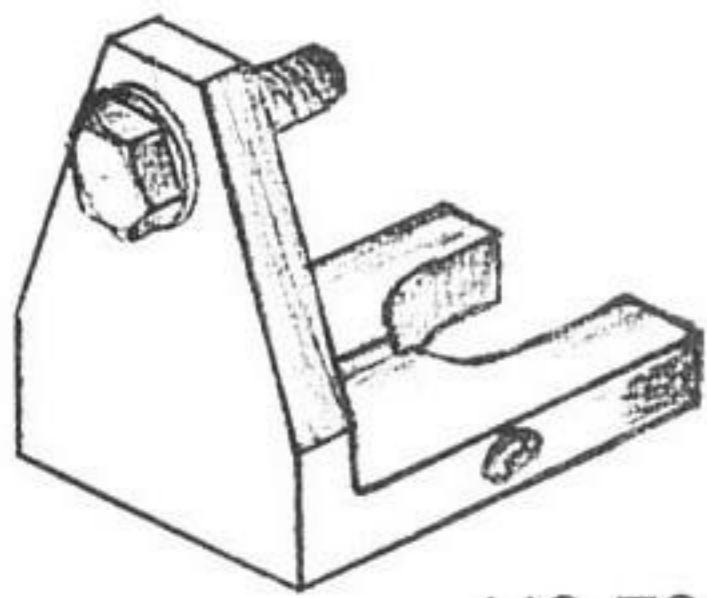

US 786

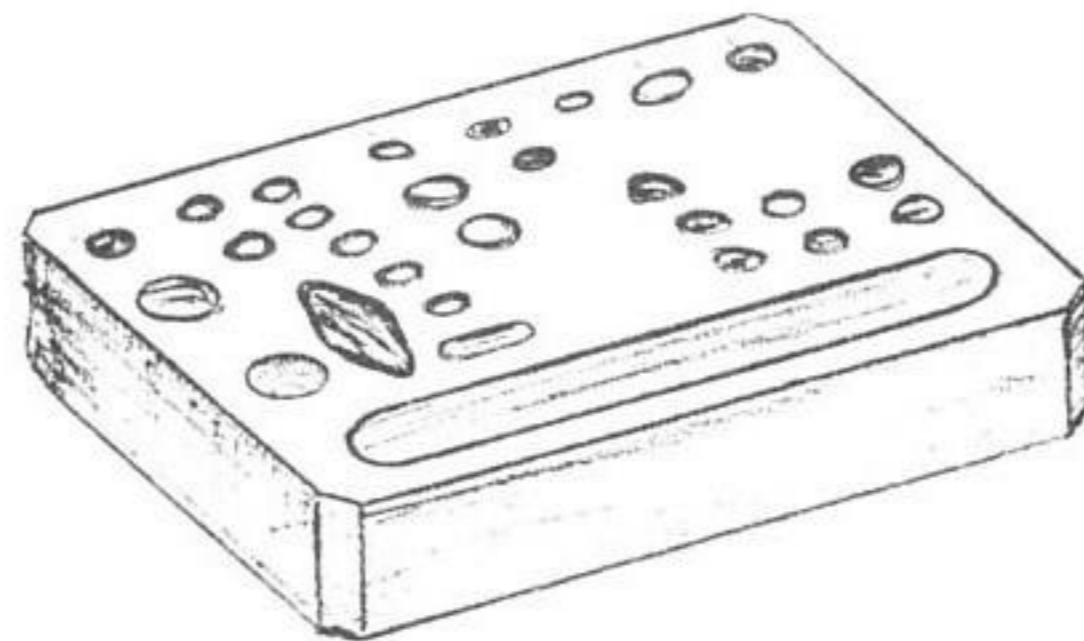

US 787

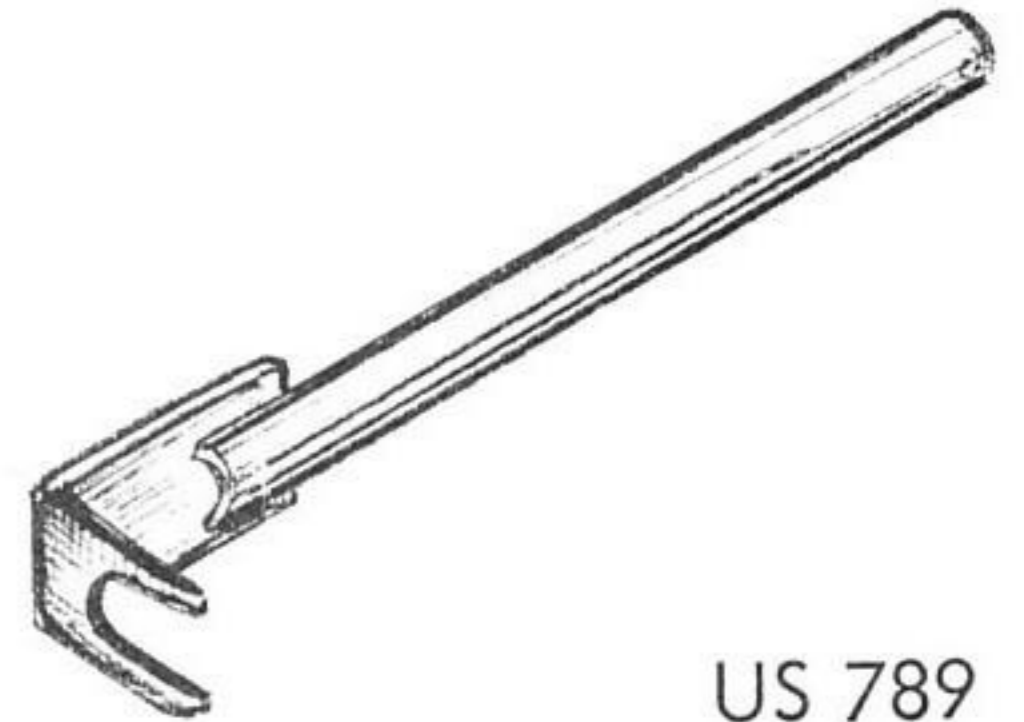

US 789

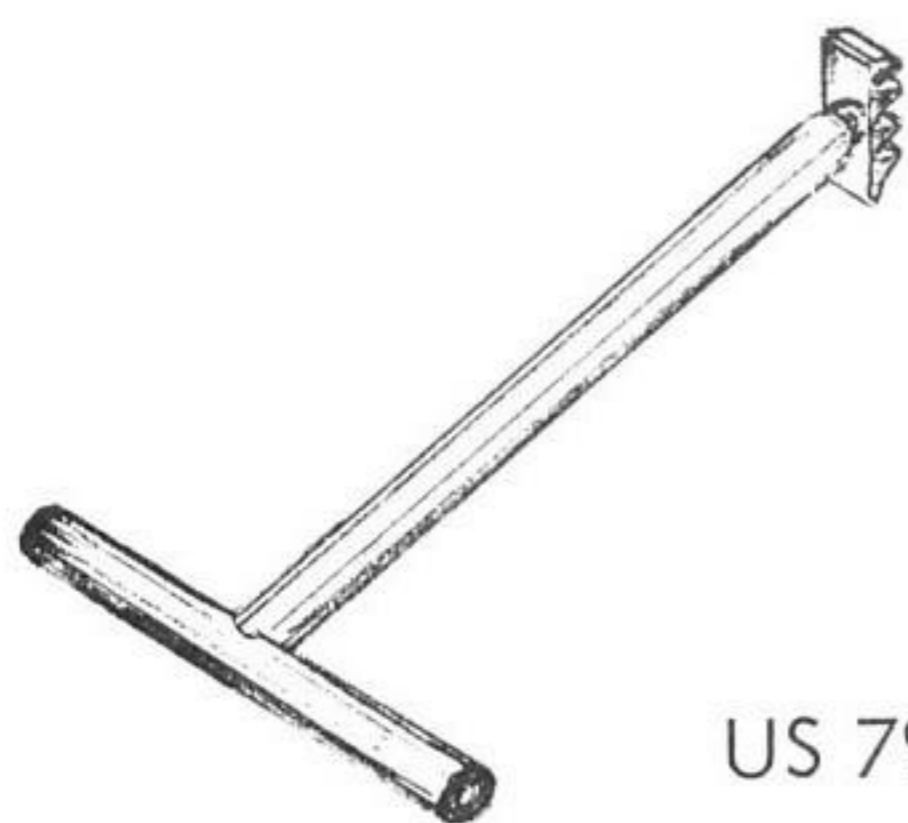

US 790



US 791



US 792

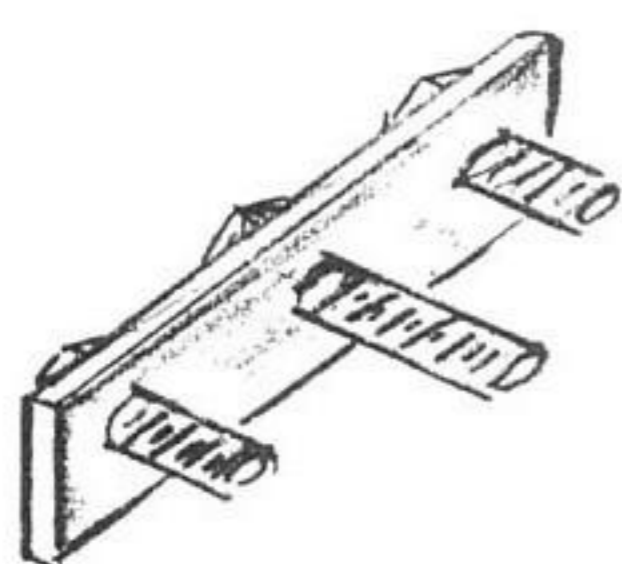

US 797/1

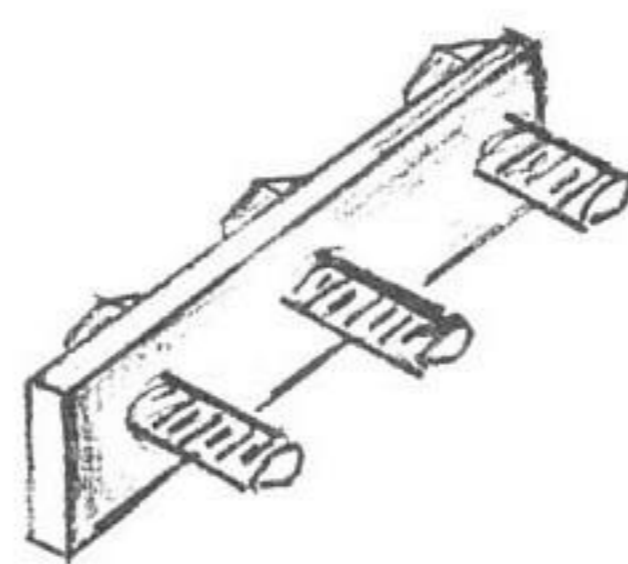

US 797/2

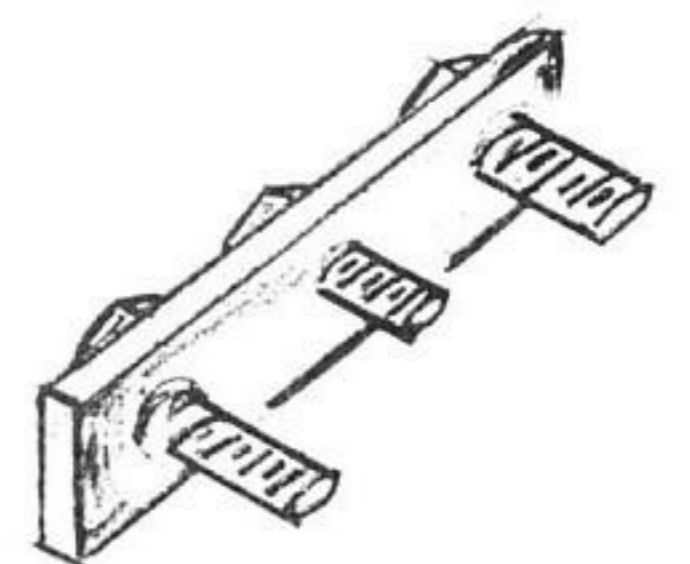

US 797/3

Special TOOLS

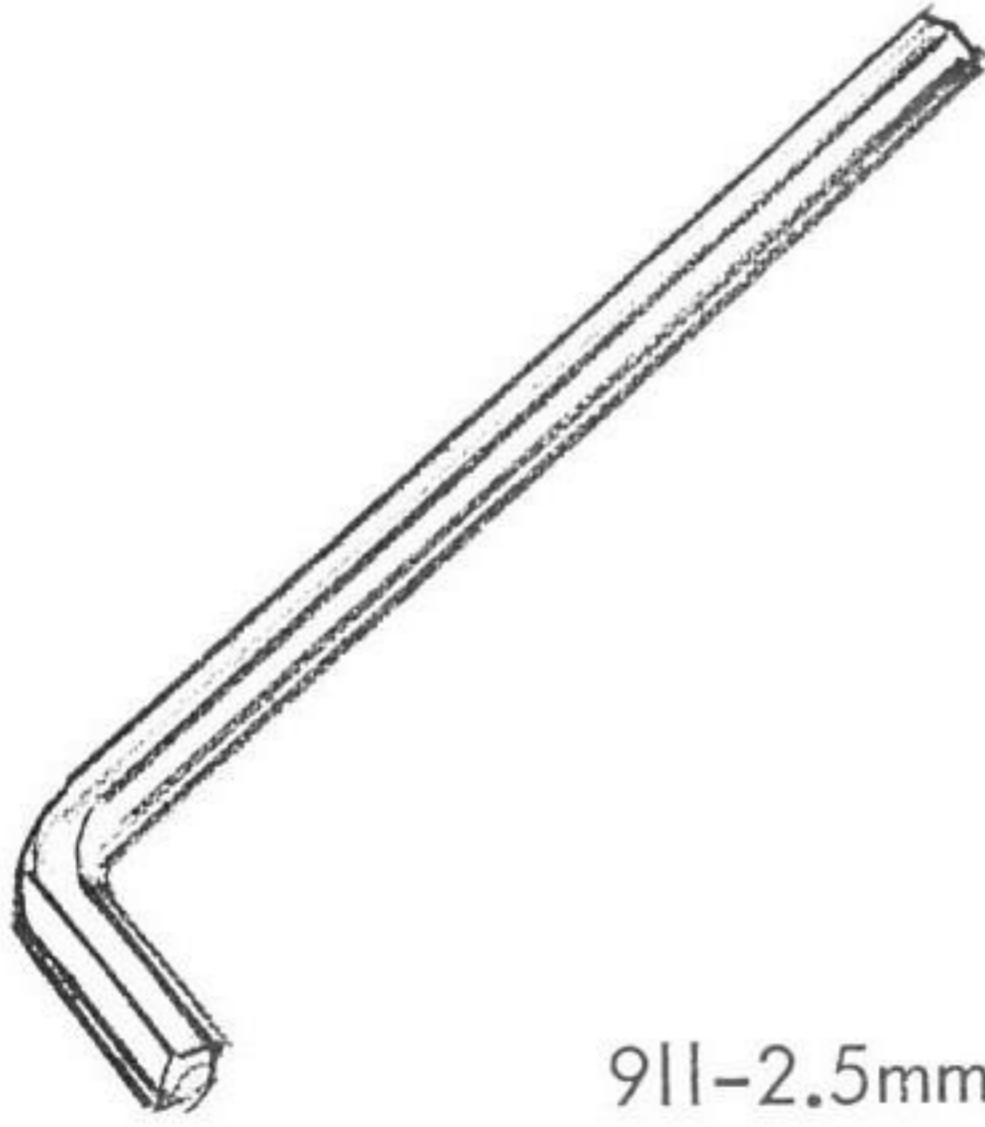

911-2.5mm

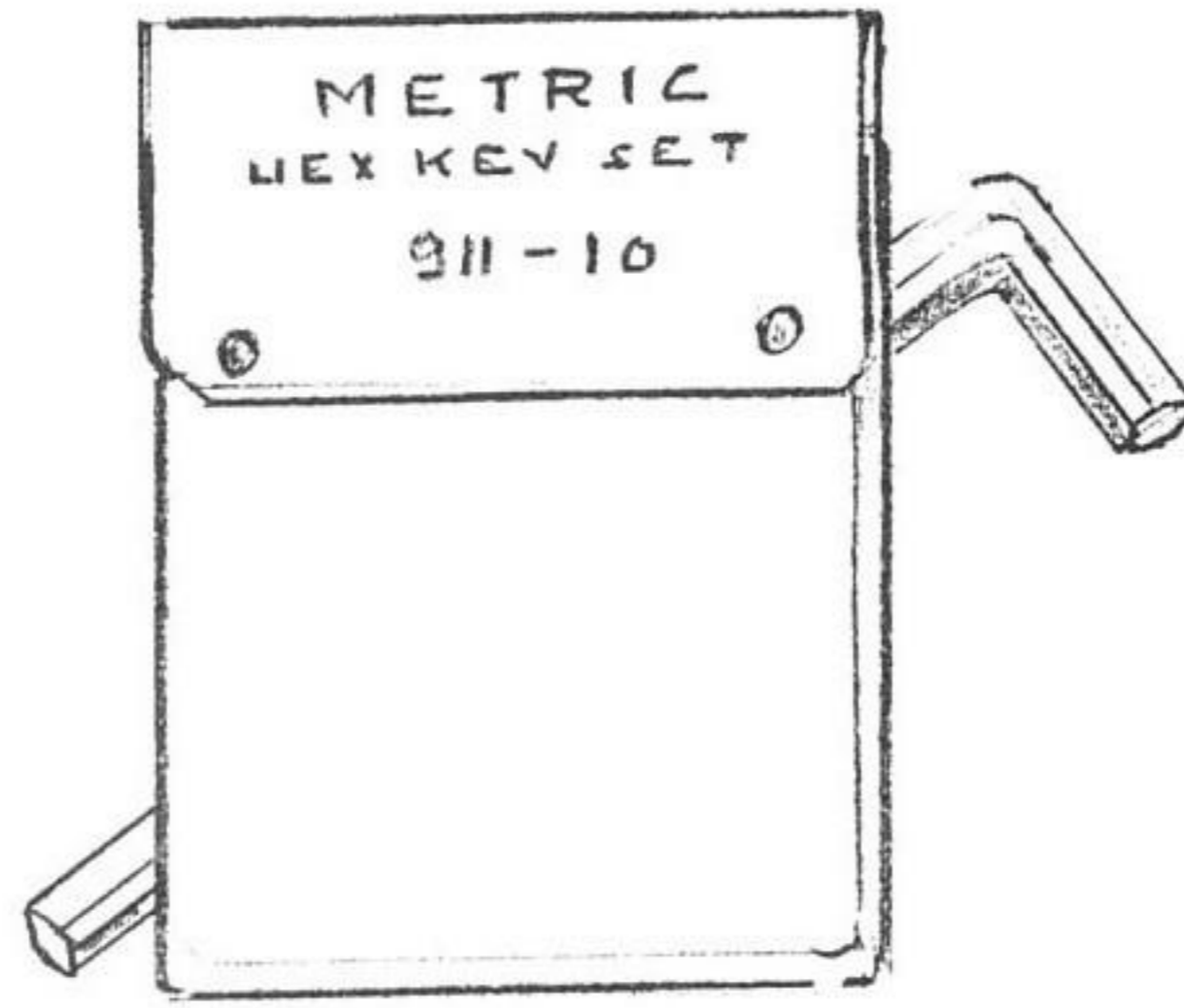

911-10

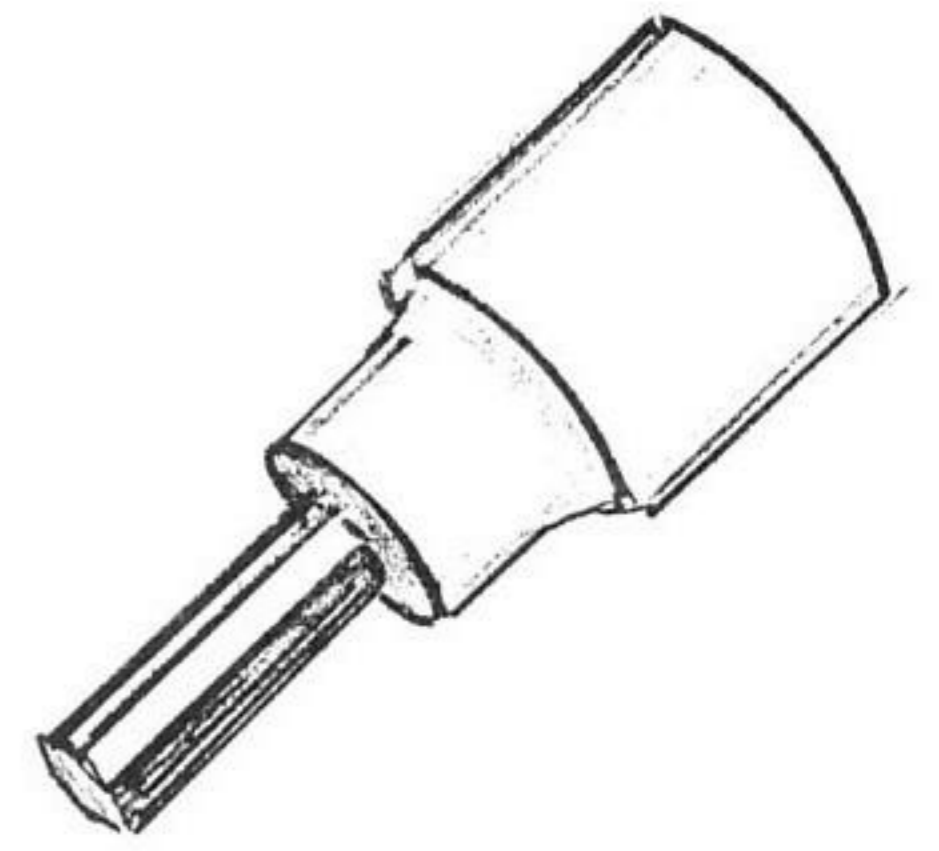

JT-5



JT-6

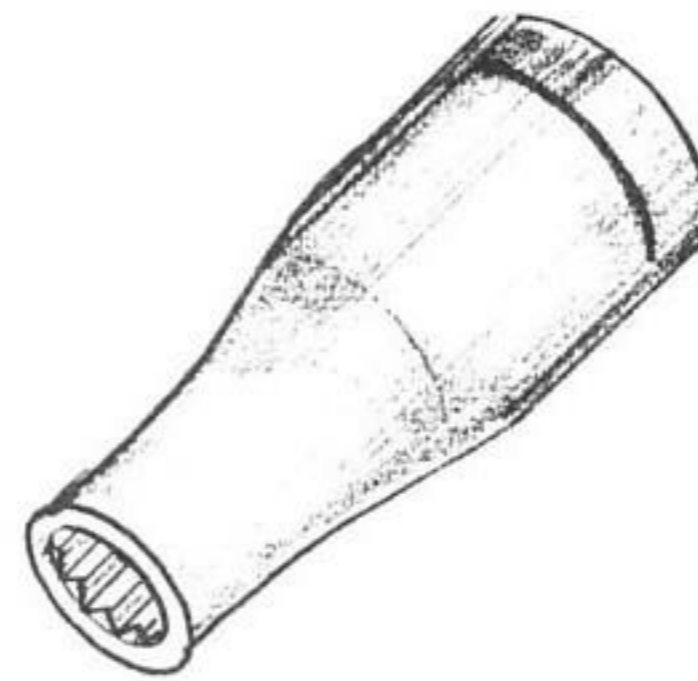

R 8

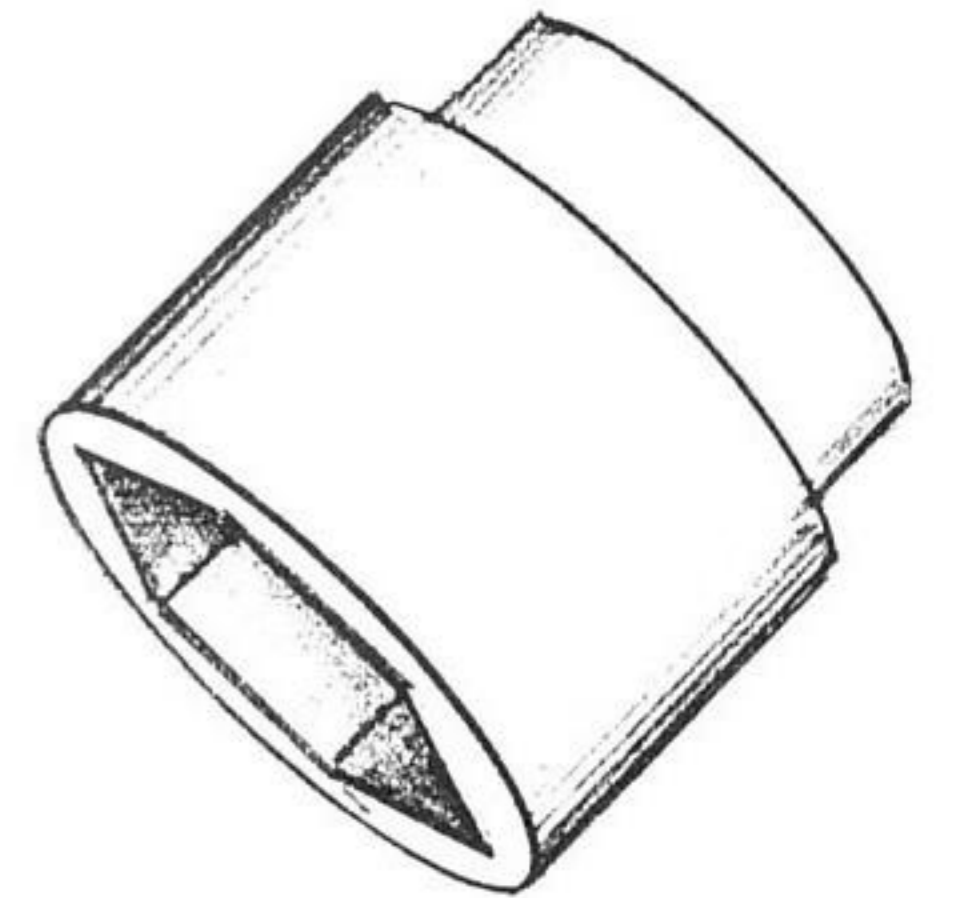

US 163 B

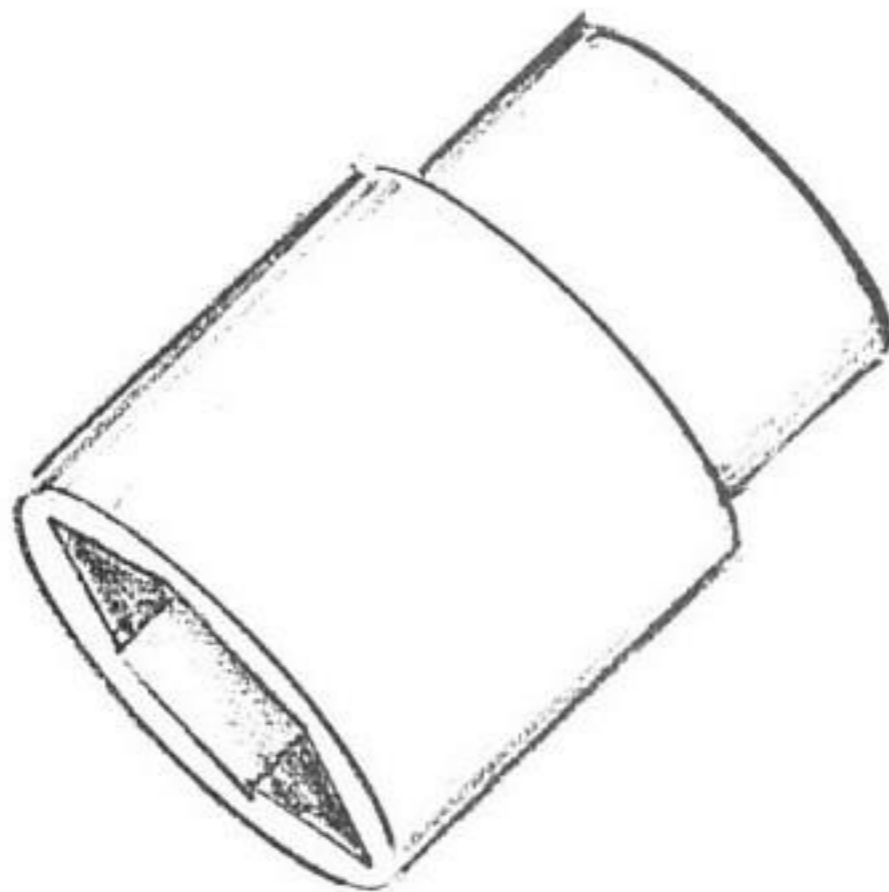

US 163 C

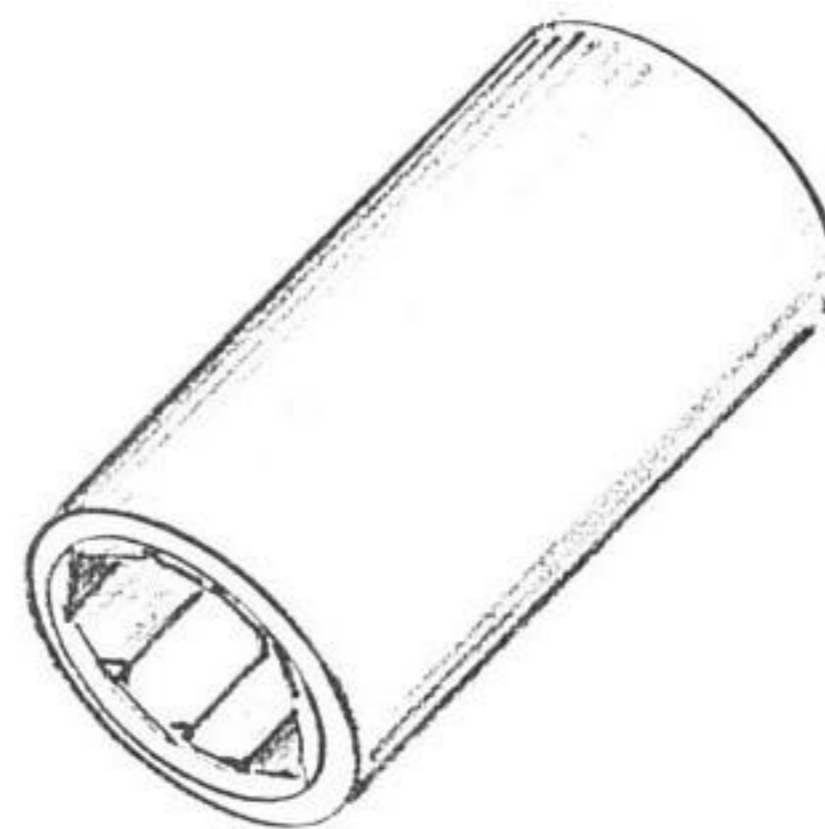

US 163 D

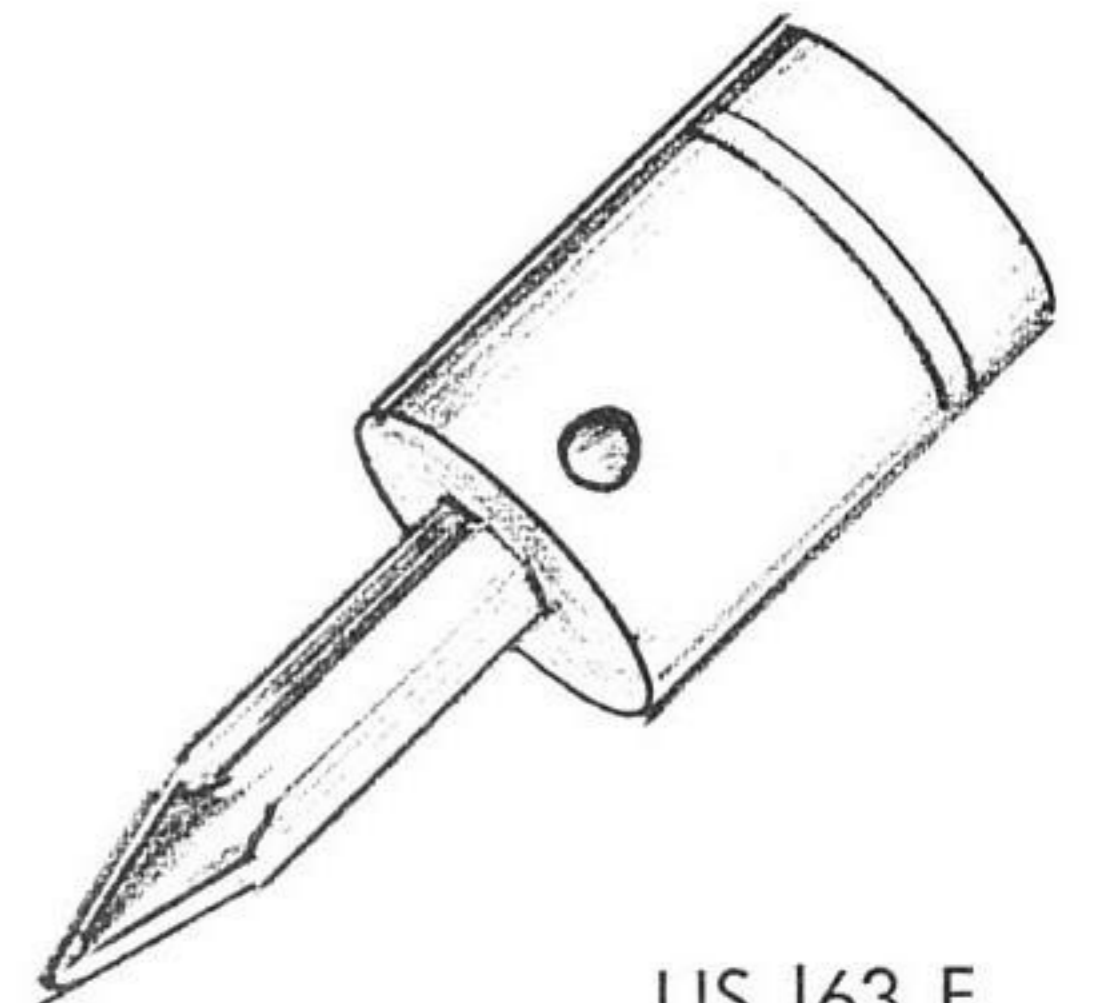

US 163 E



US 1001
US 1003



US 1002

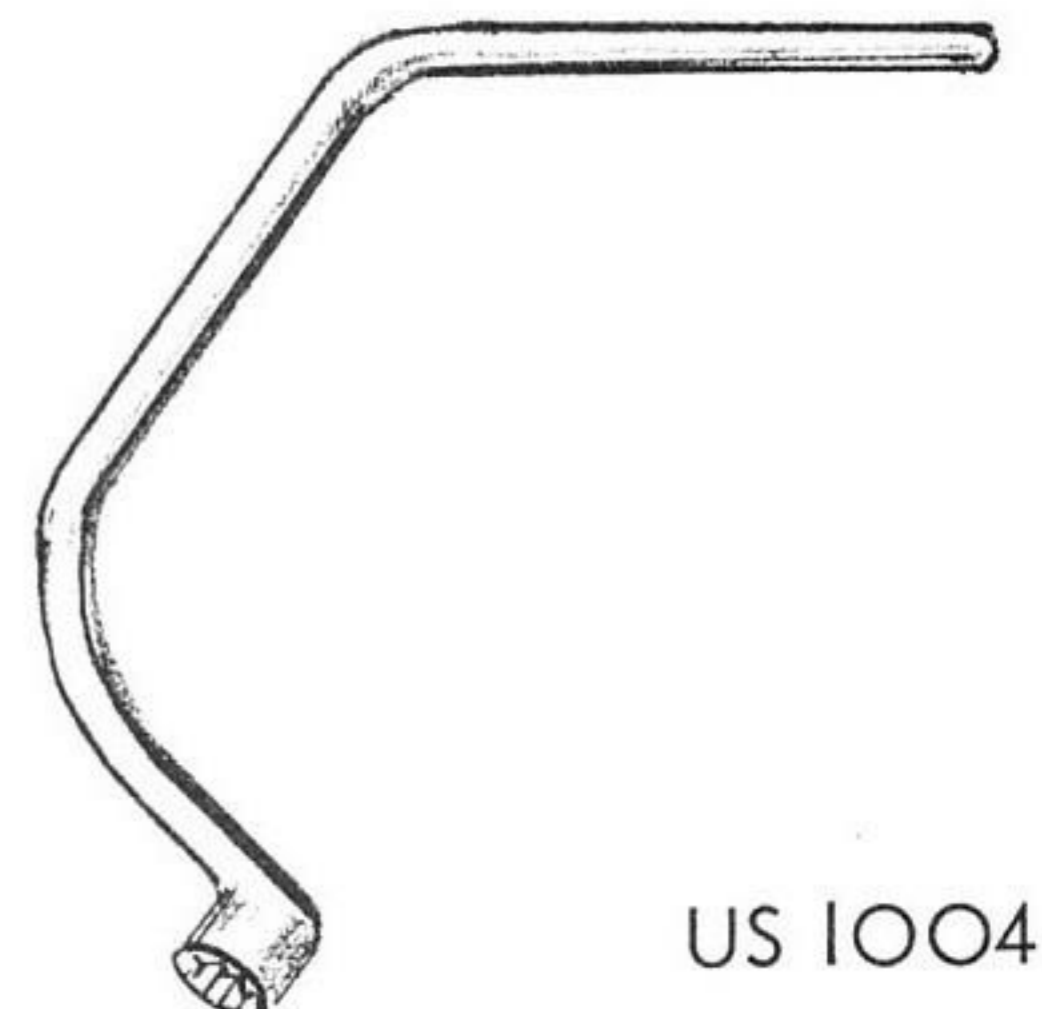

US 1004

Special TOOLS



US 163 F

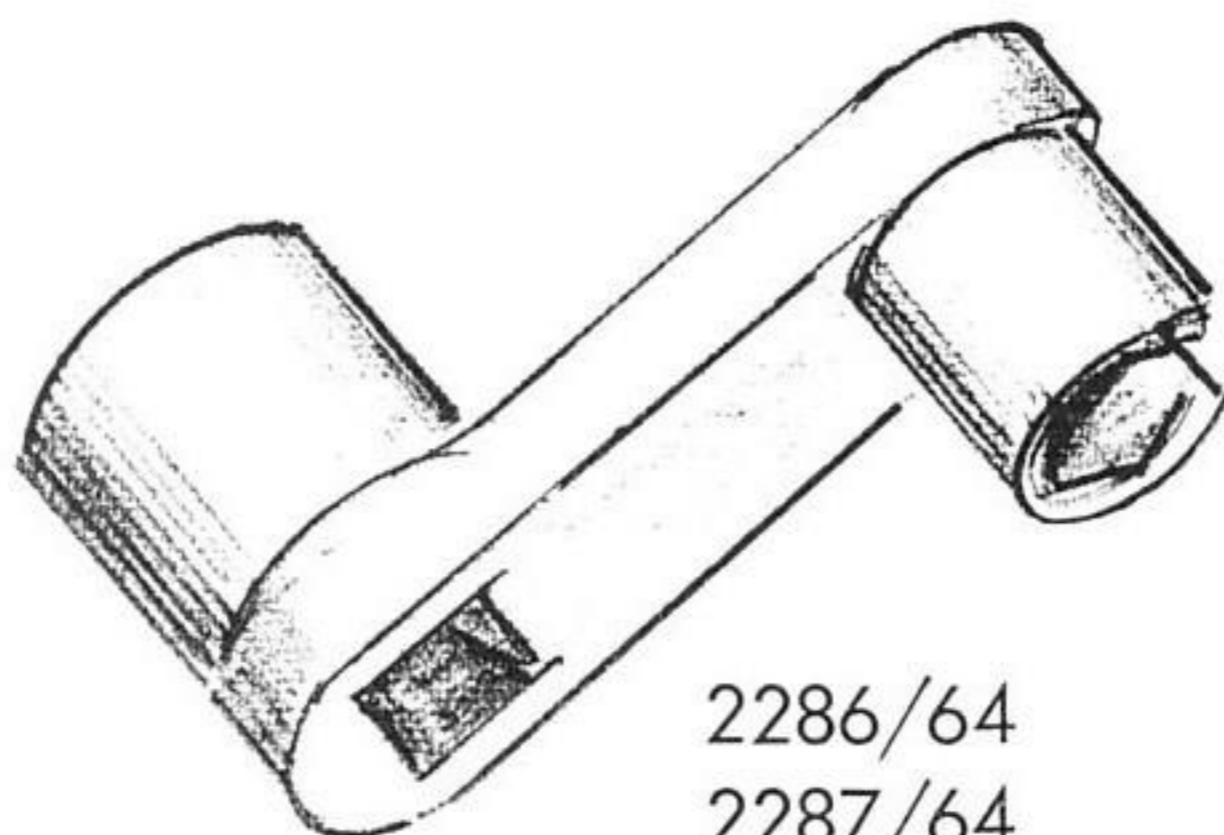

2286/64
2287/64

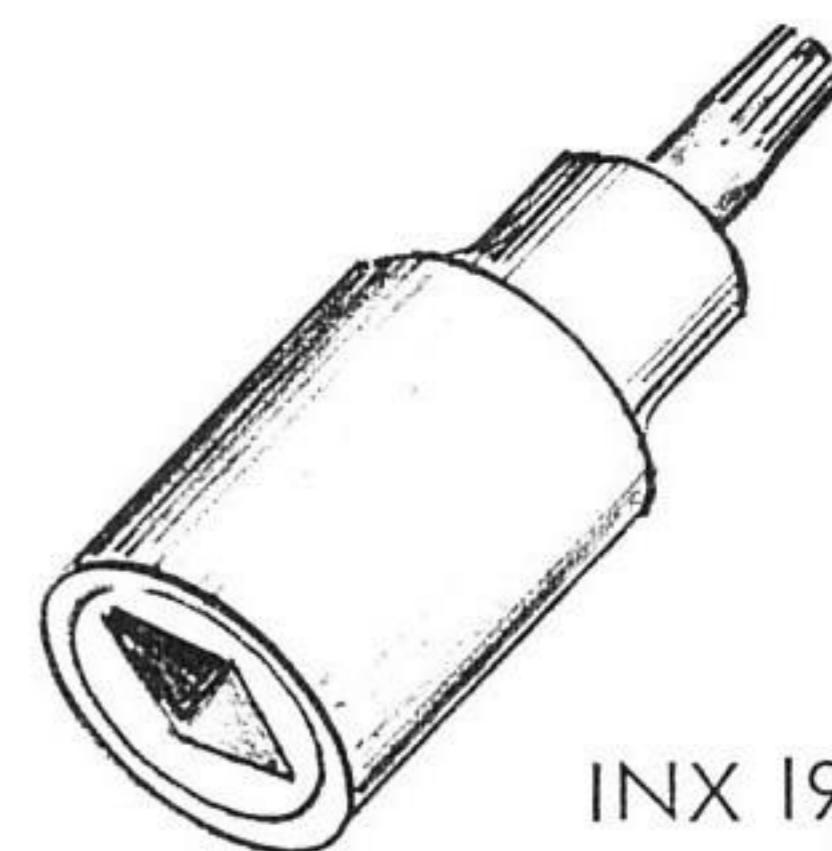

INX 19/M6

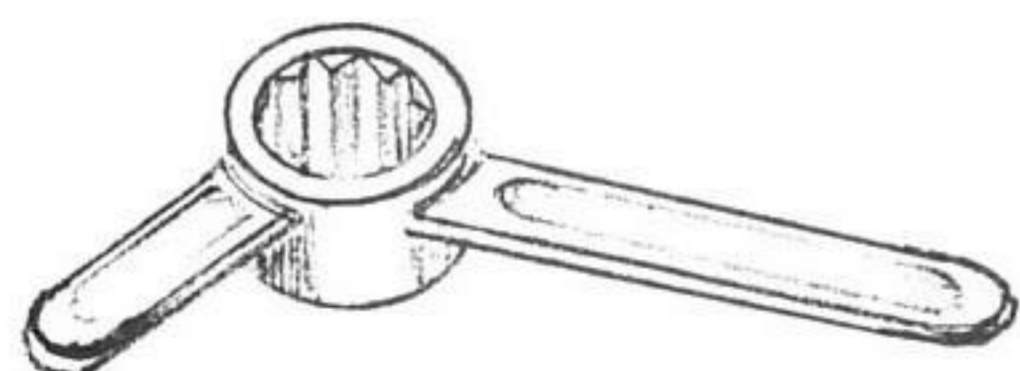

US 1024



US 1011

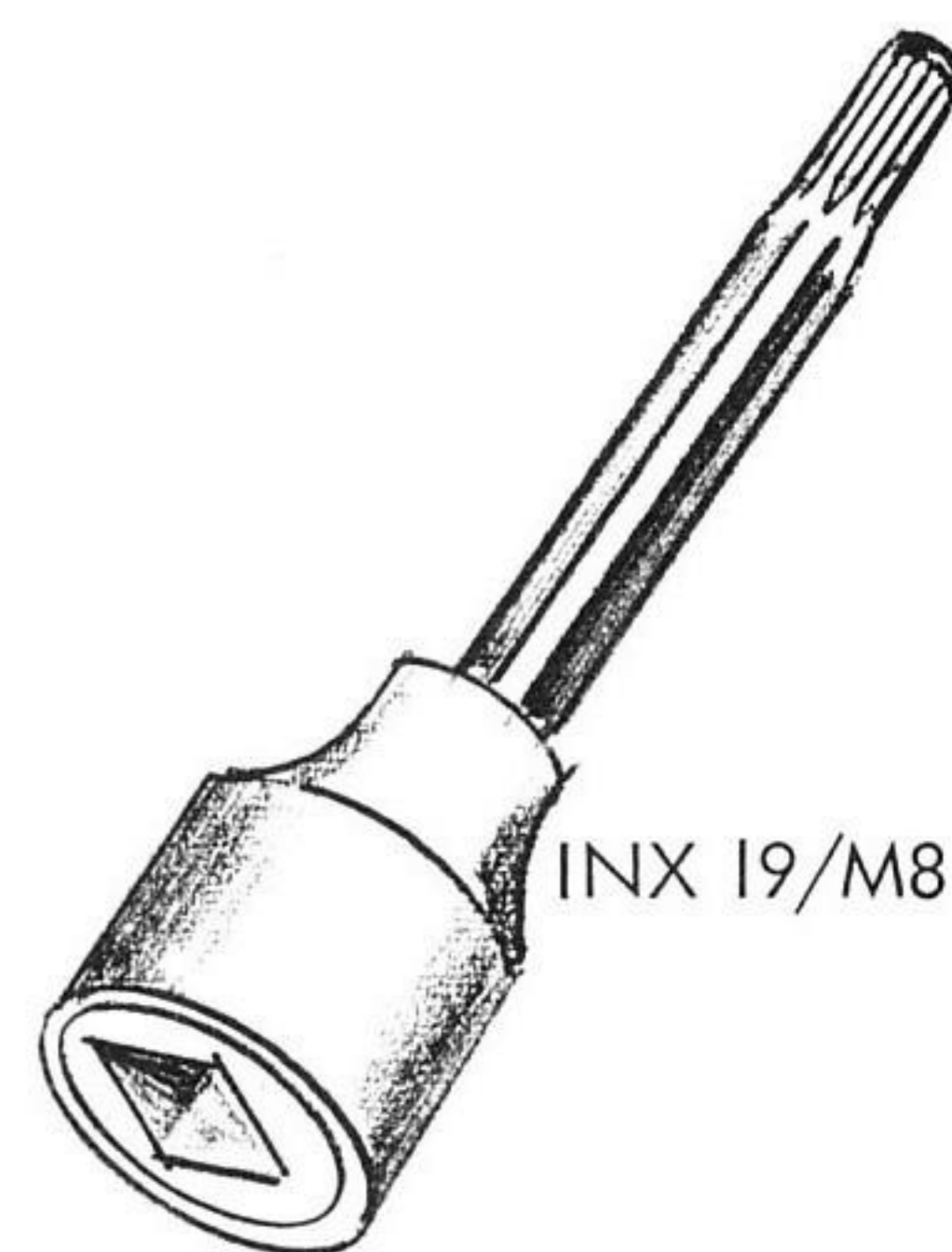

INX 19/M8

Special TOOLS

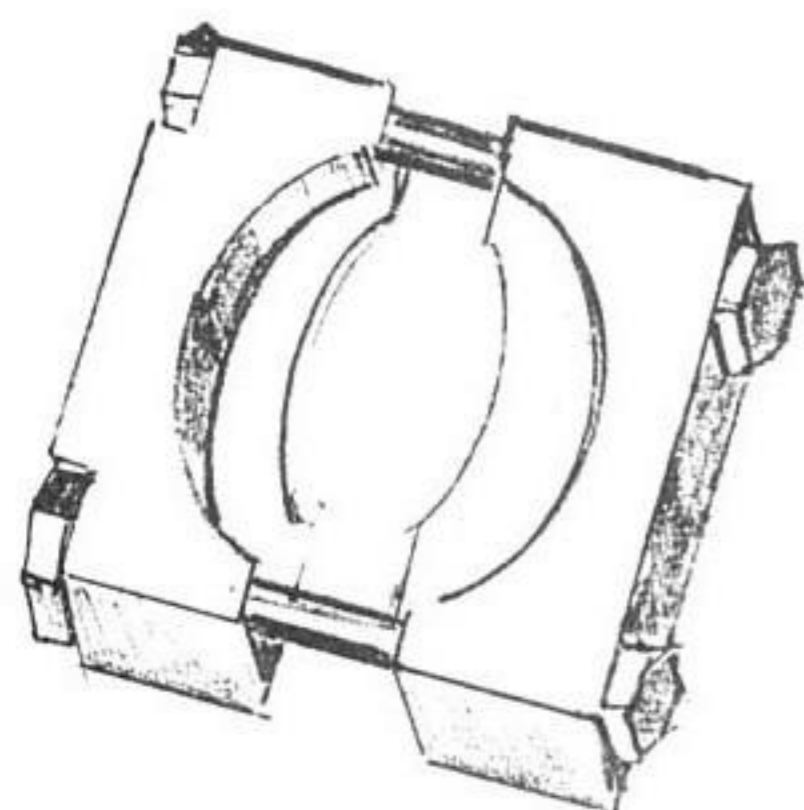

US 1010

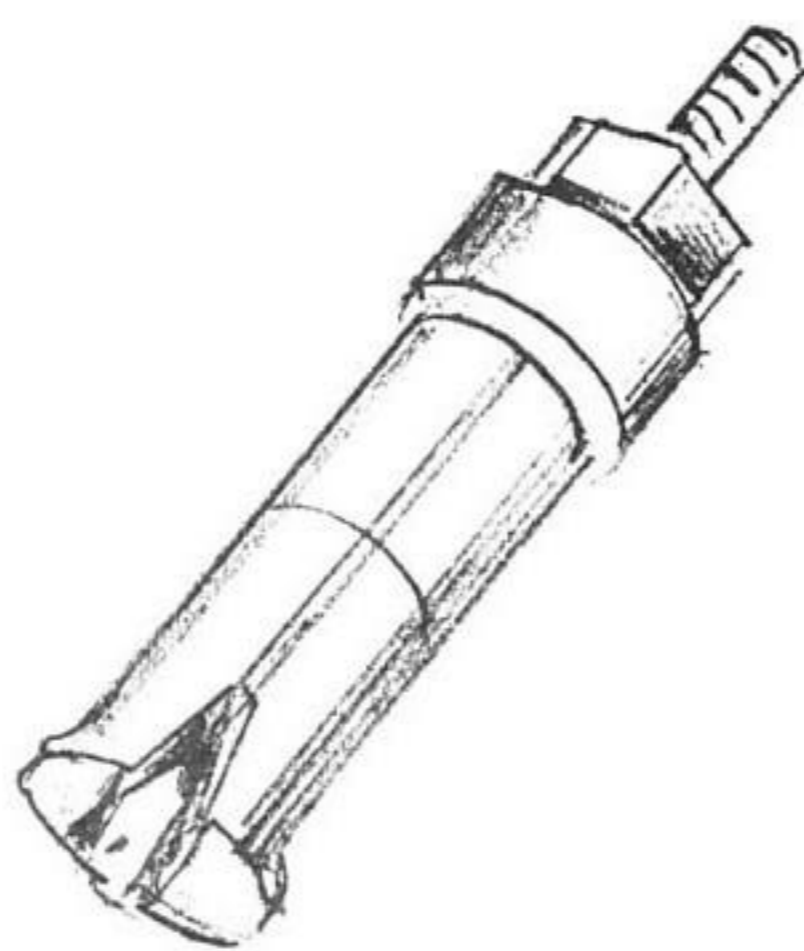

21/7



22/2

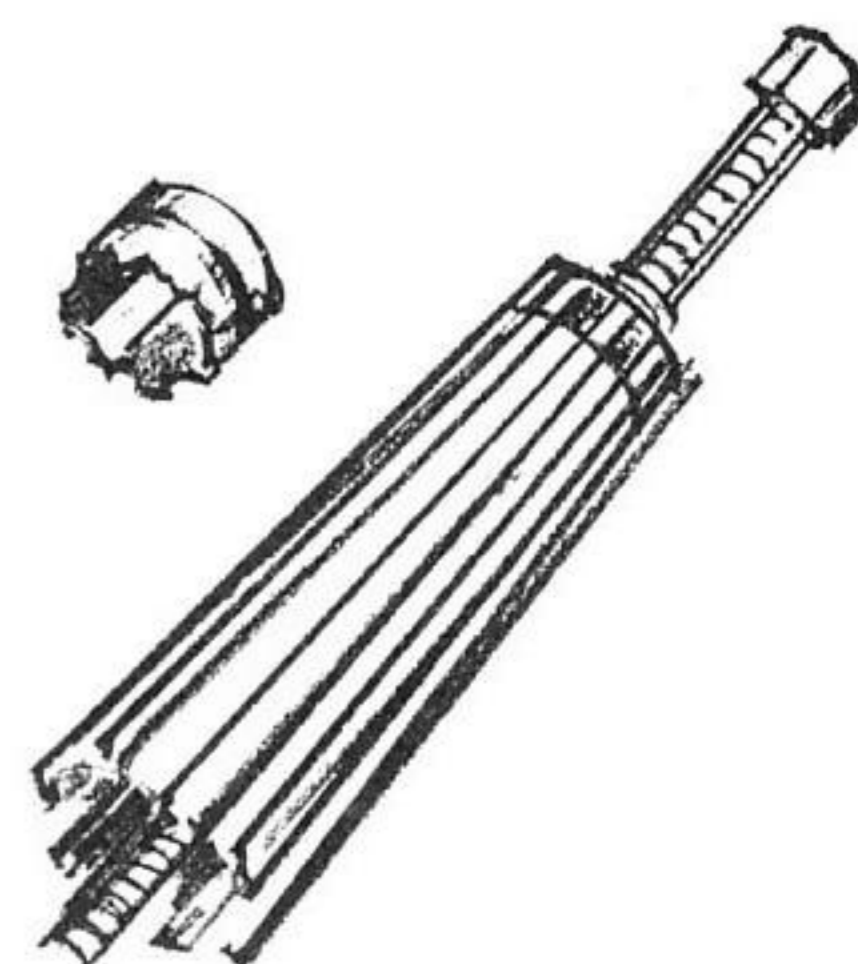

6306

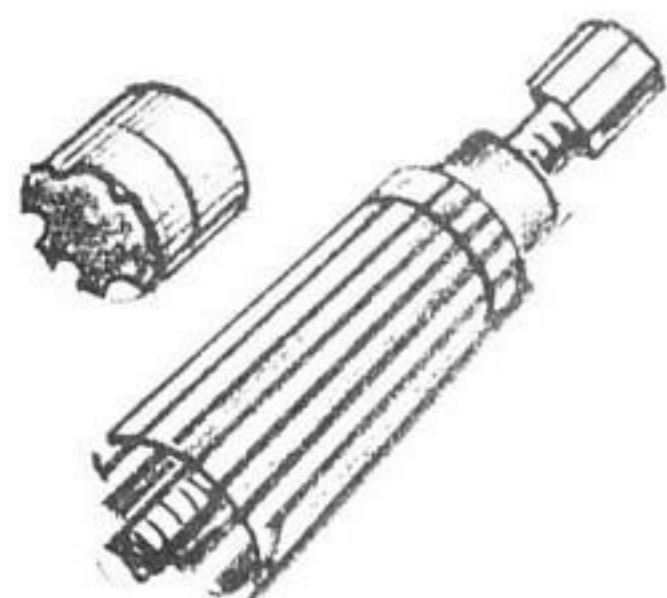

6305

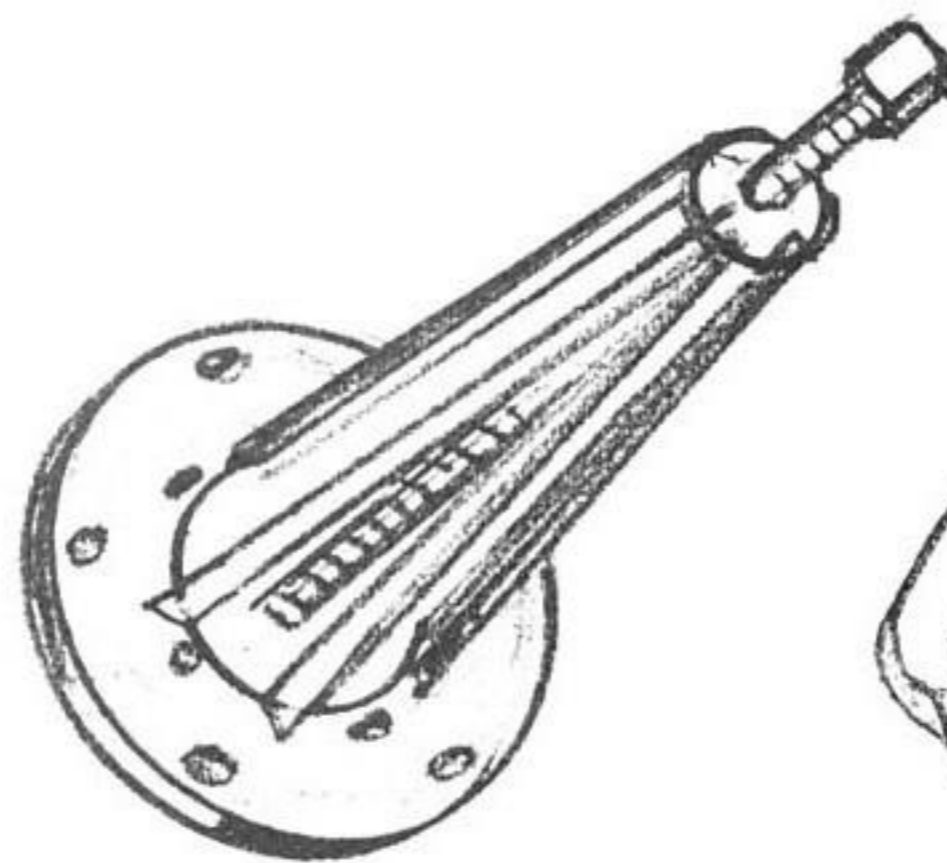

US 202 BZ

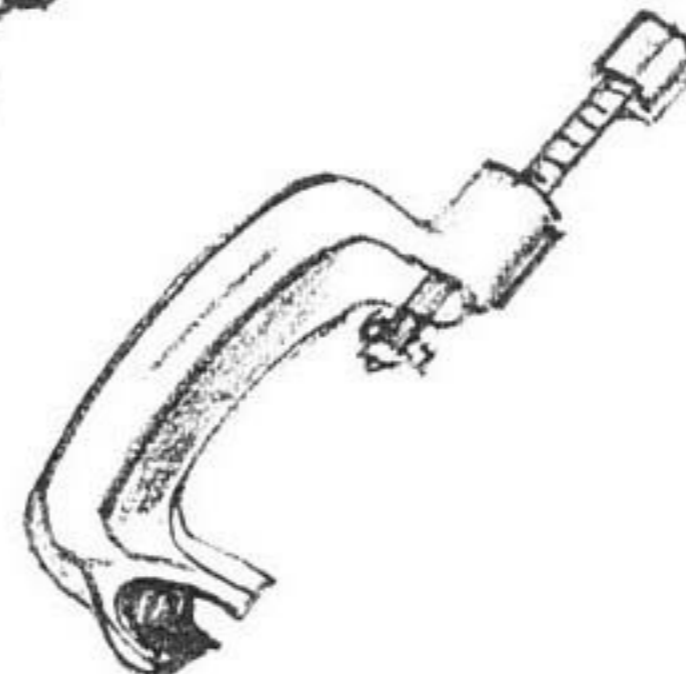

US 235

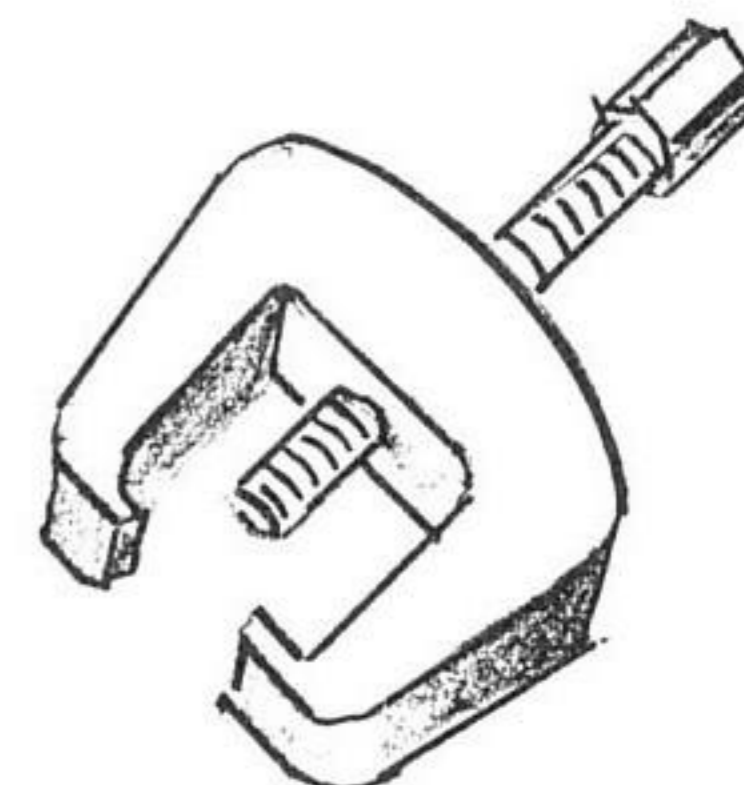

US 236

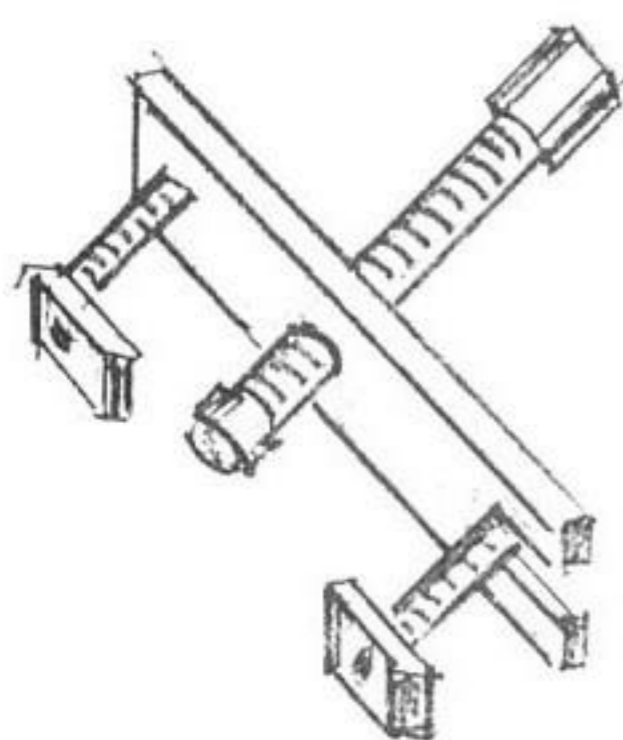

US 237

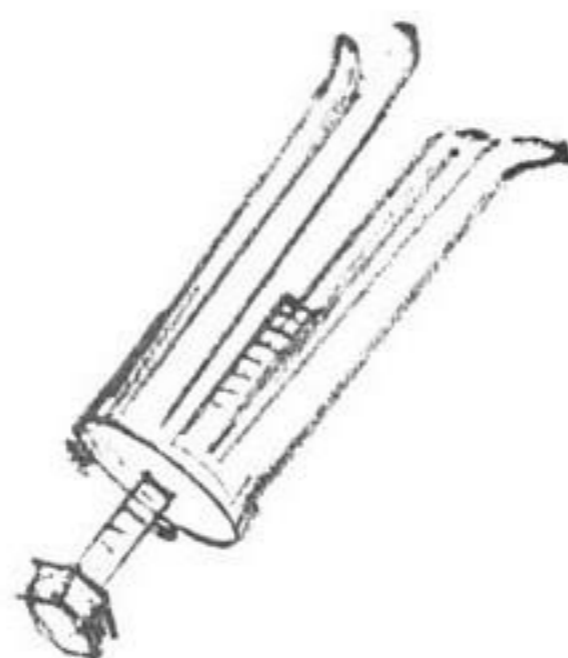

US 241 A

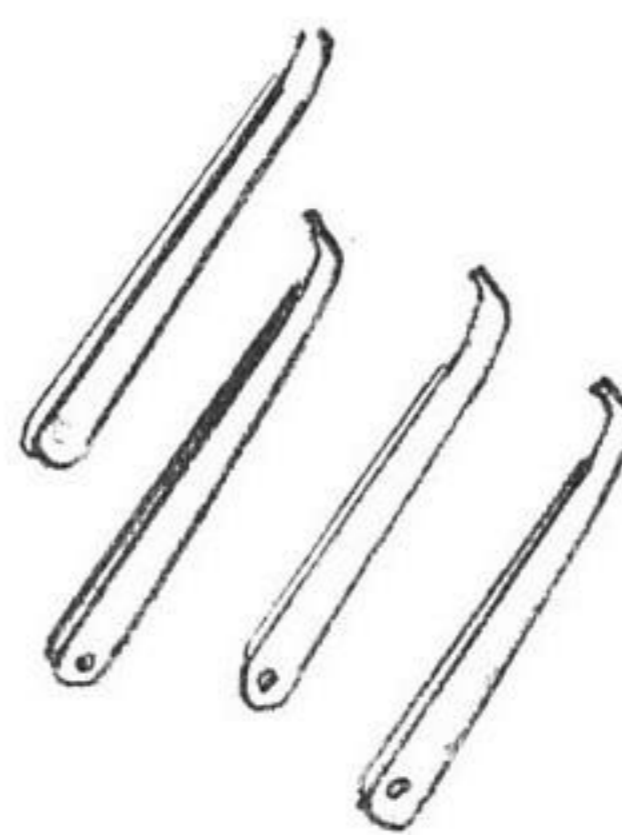

US 241 A-4



US 266 H

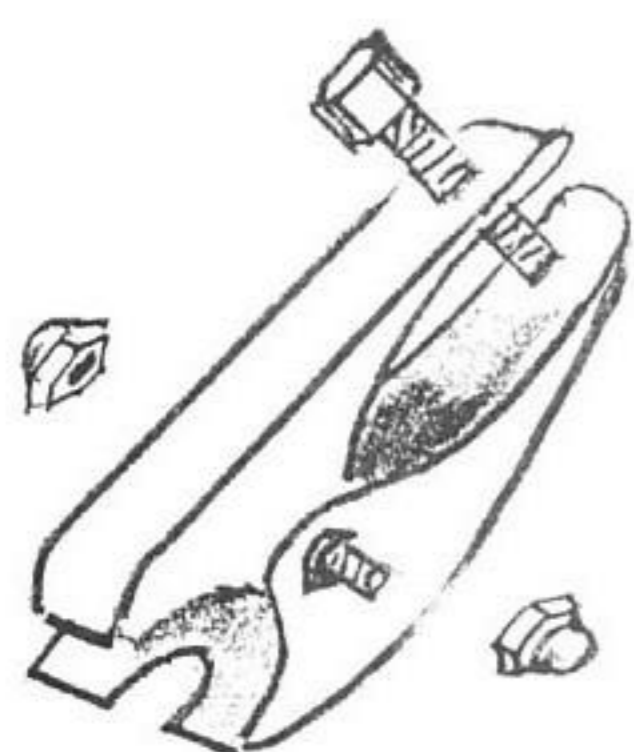

US 267 A

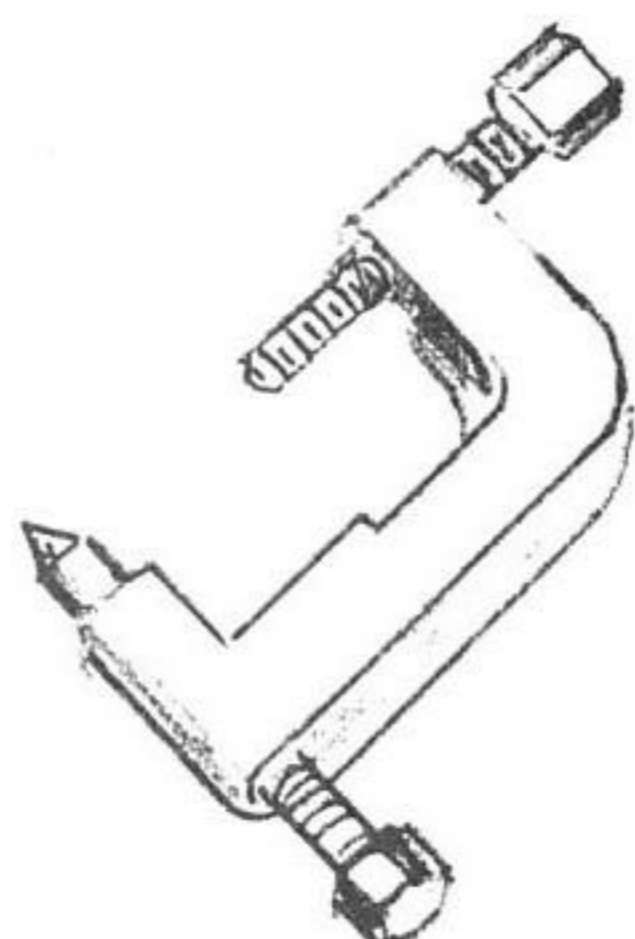

US 276 A

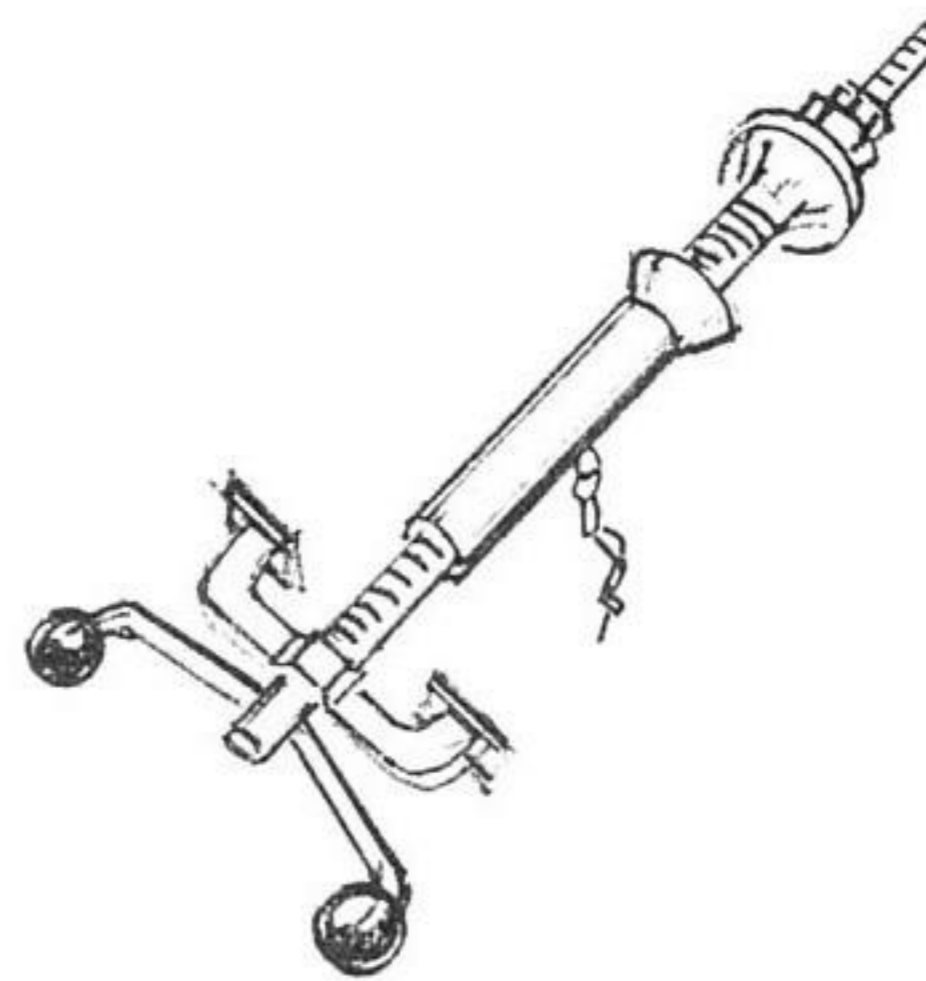

US 639

Special **TOOLS**

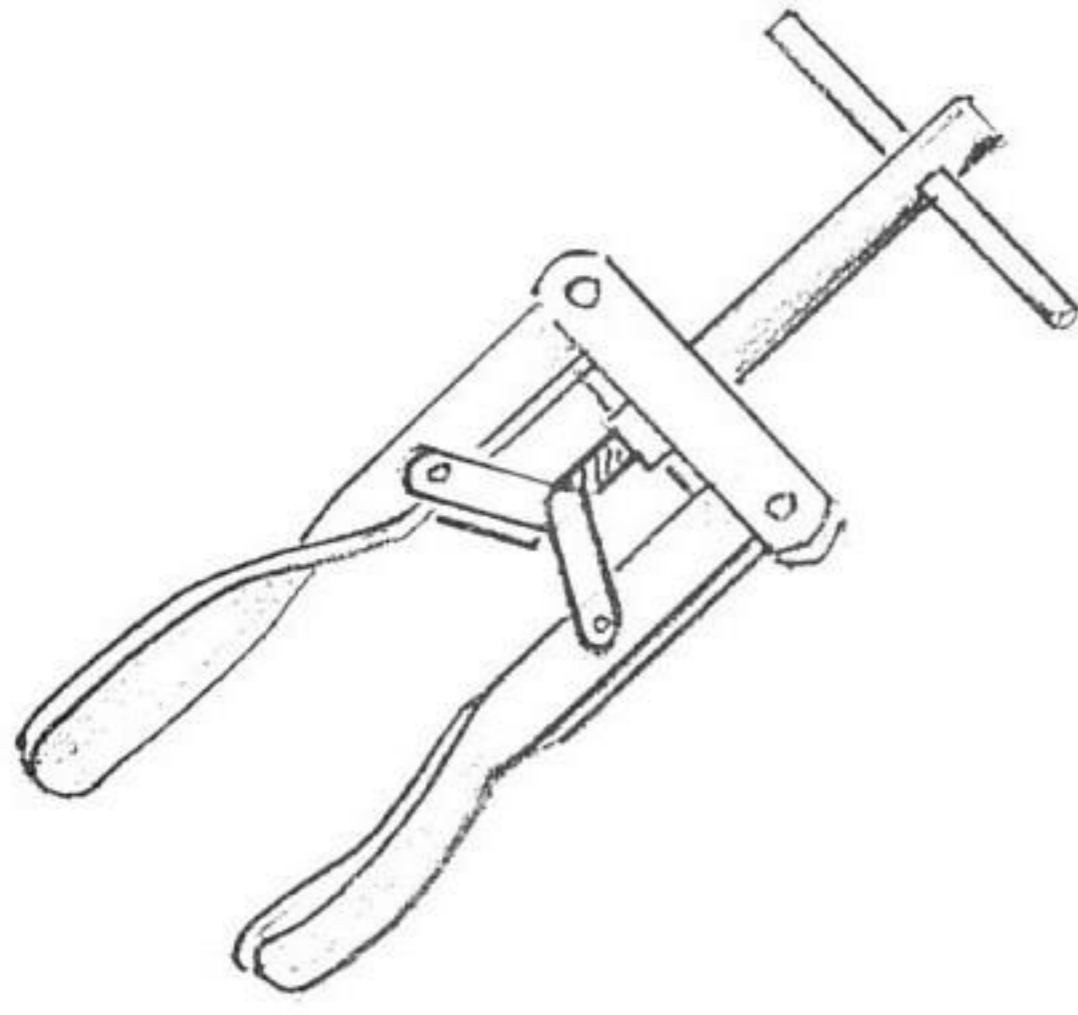

3.9314-1800.2

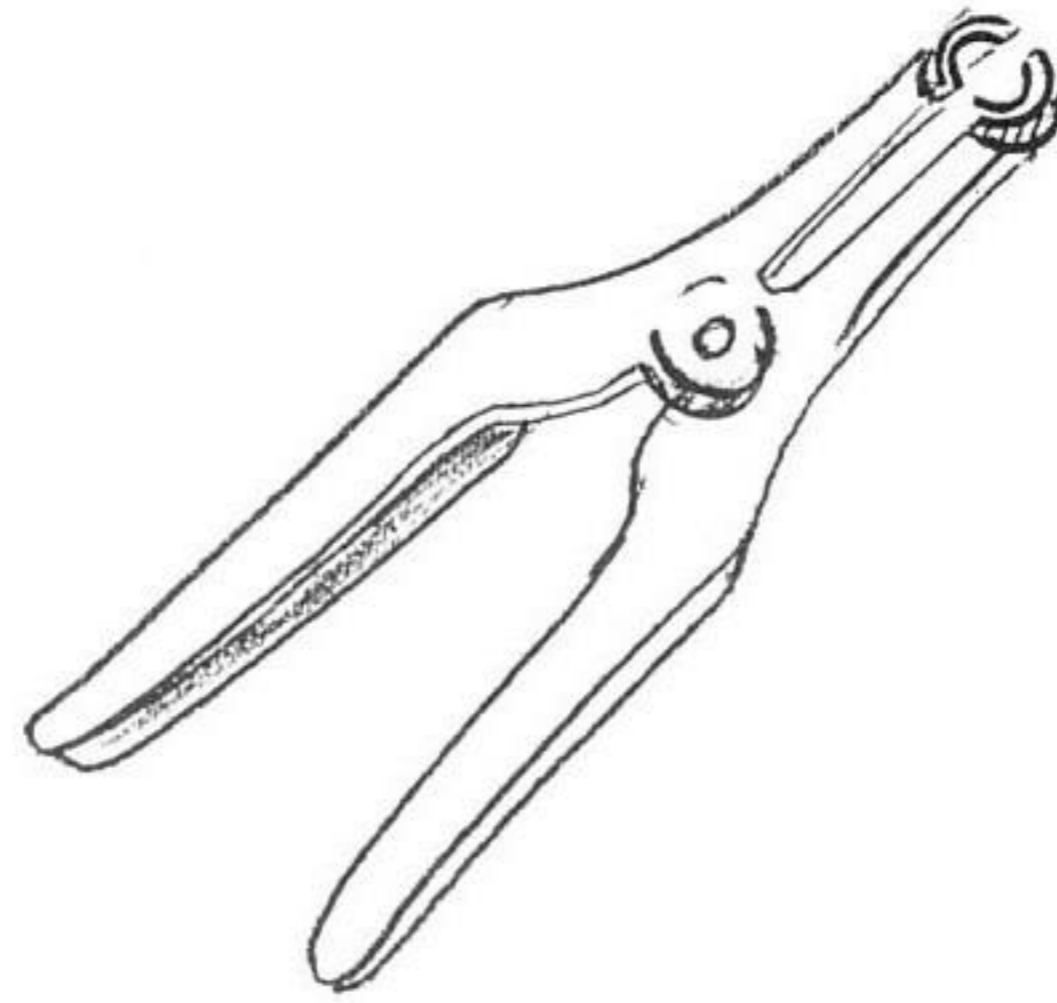

3.9314-1500.2

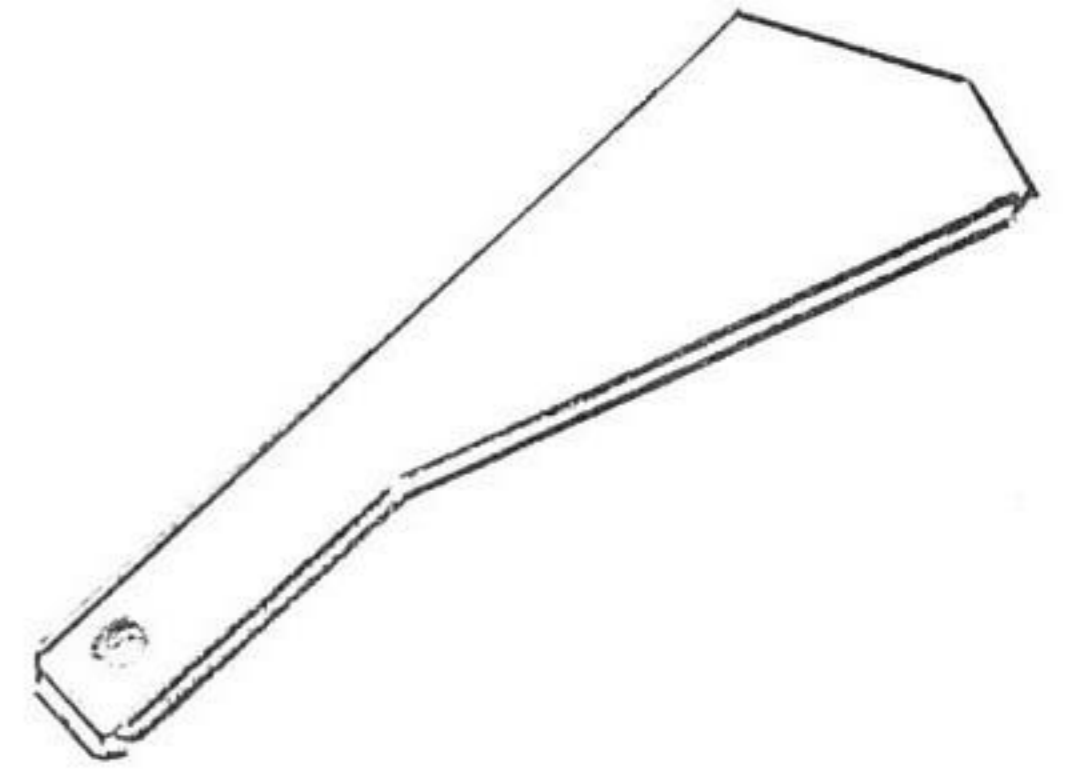

3.9314-2400.1

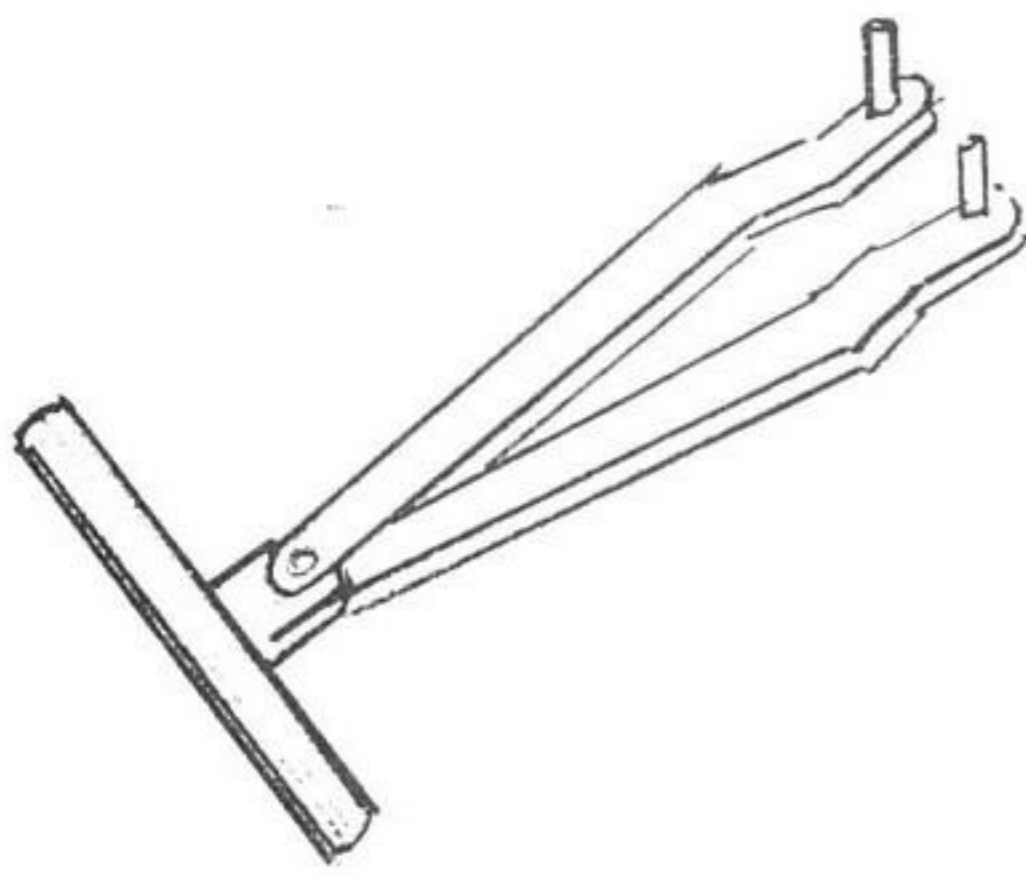

3.9314-1400.2

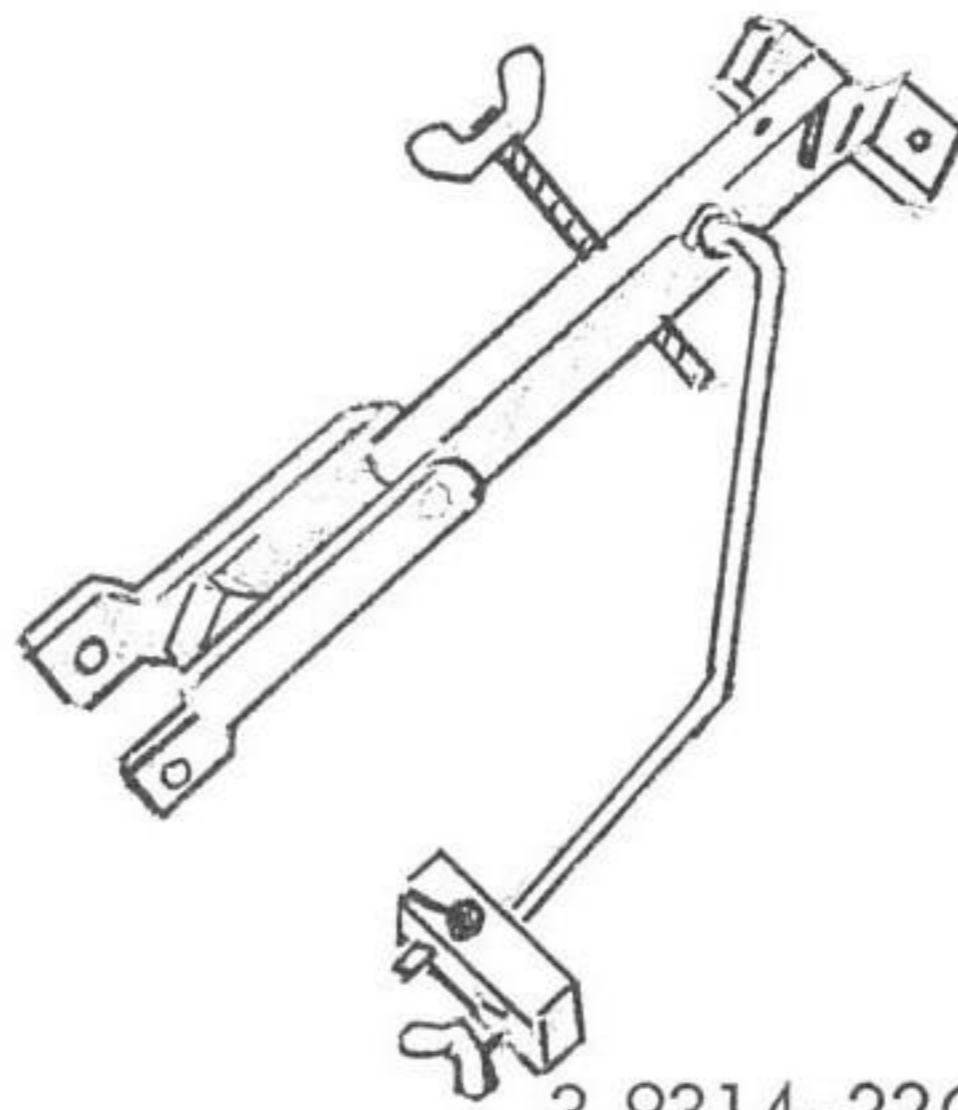

3.9314-2203.2

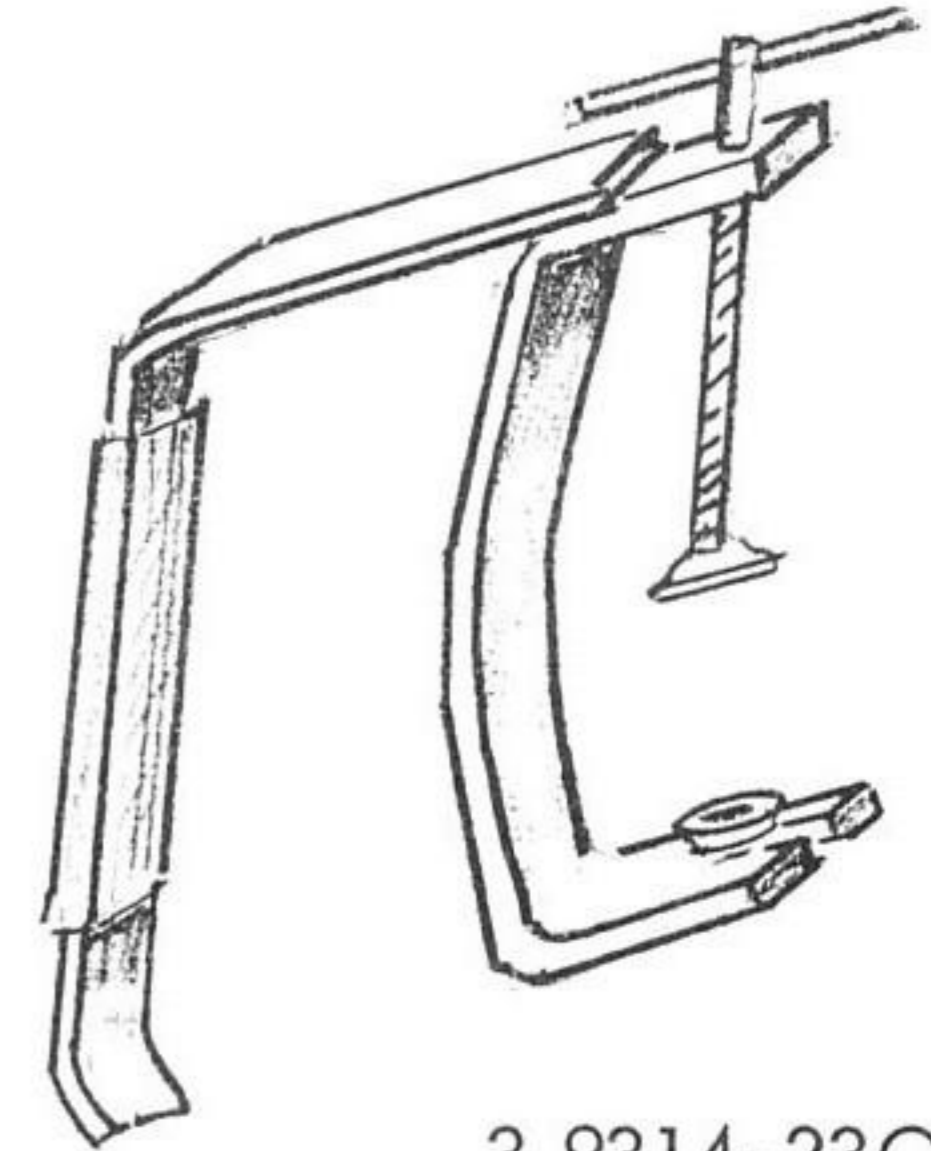

3.9314-2300.2

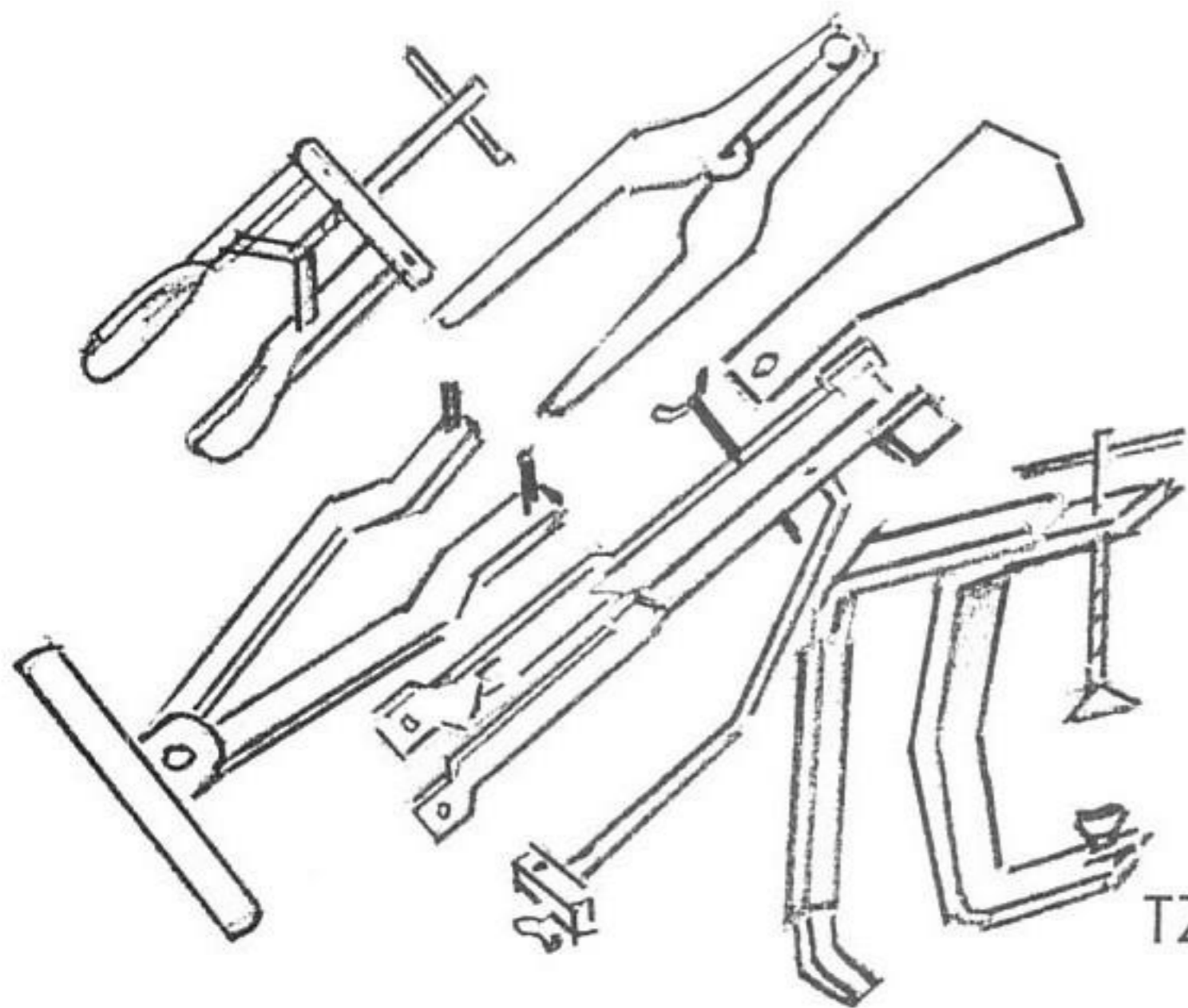

TZ 1500-6

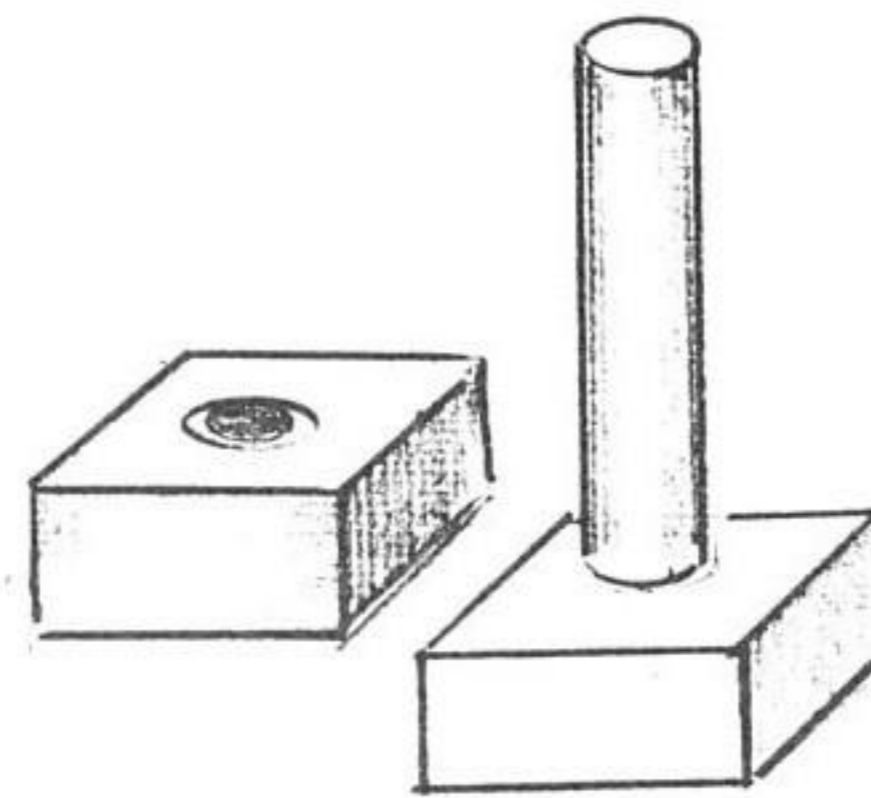

3.9314-2202.1

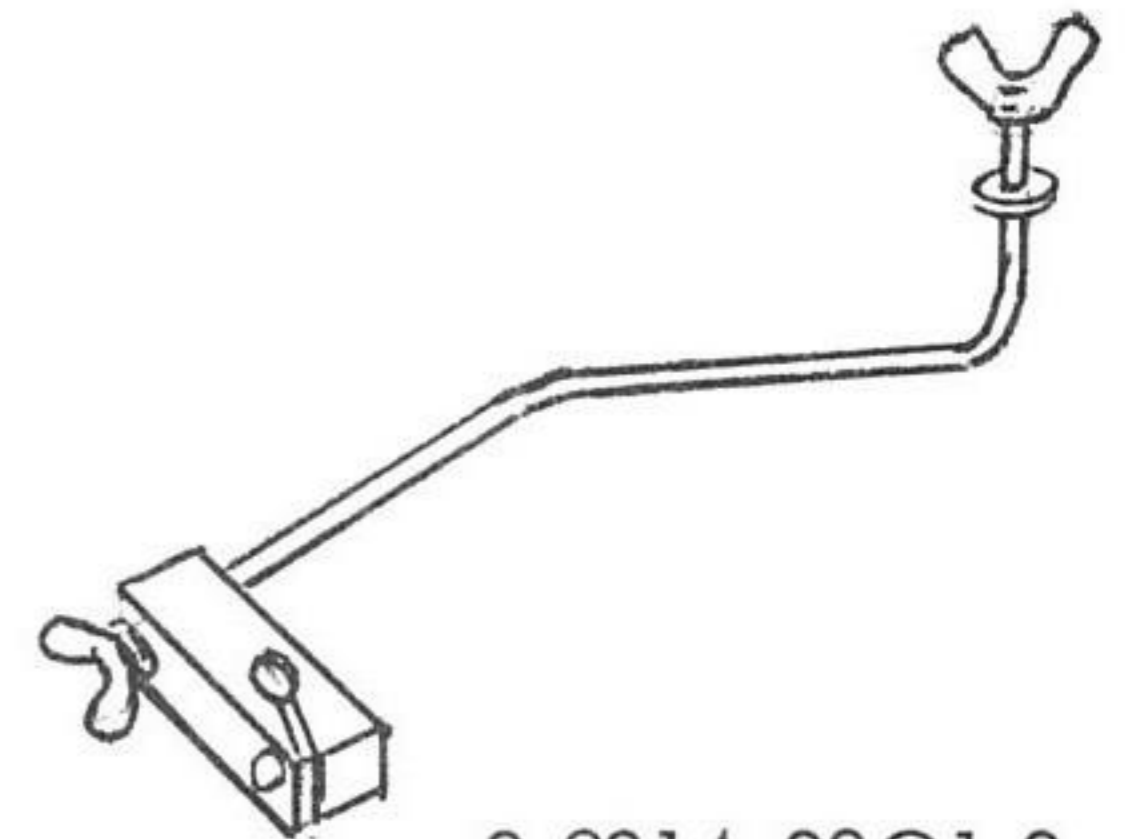

3.9314-2201.2

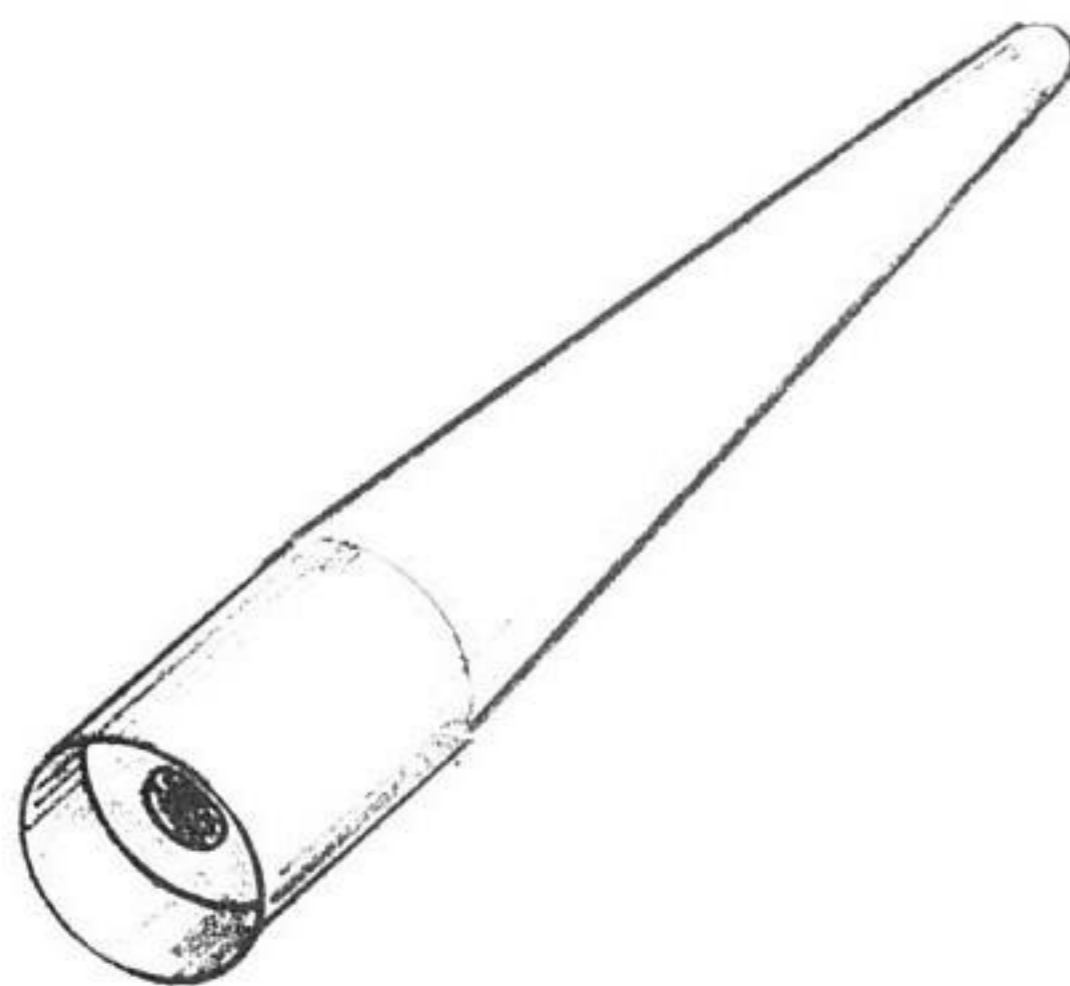

3.9314-3100.1

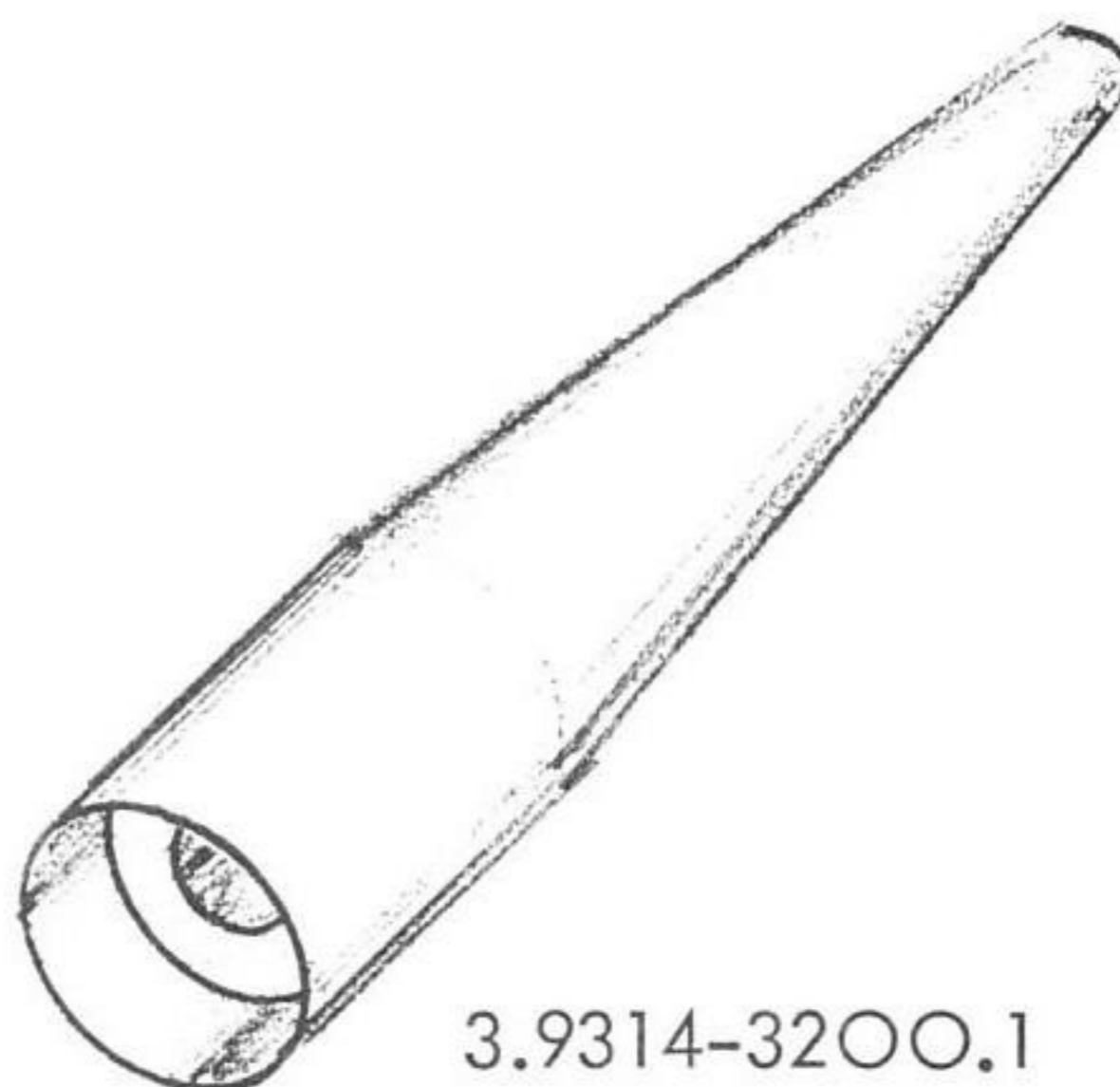

3.9314-3200.1

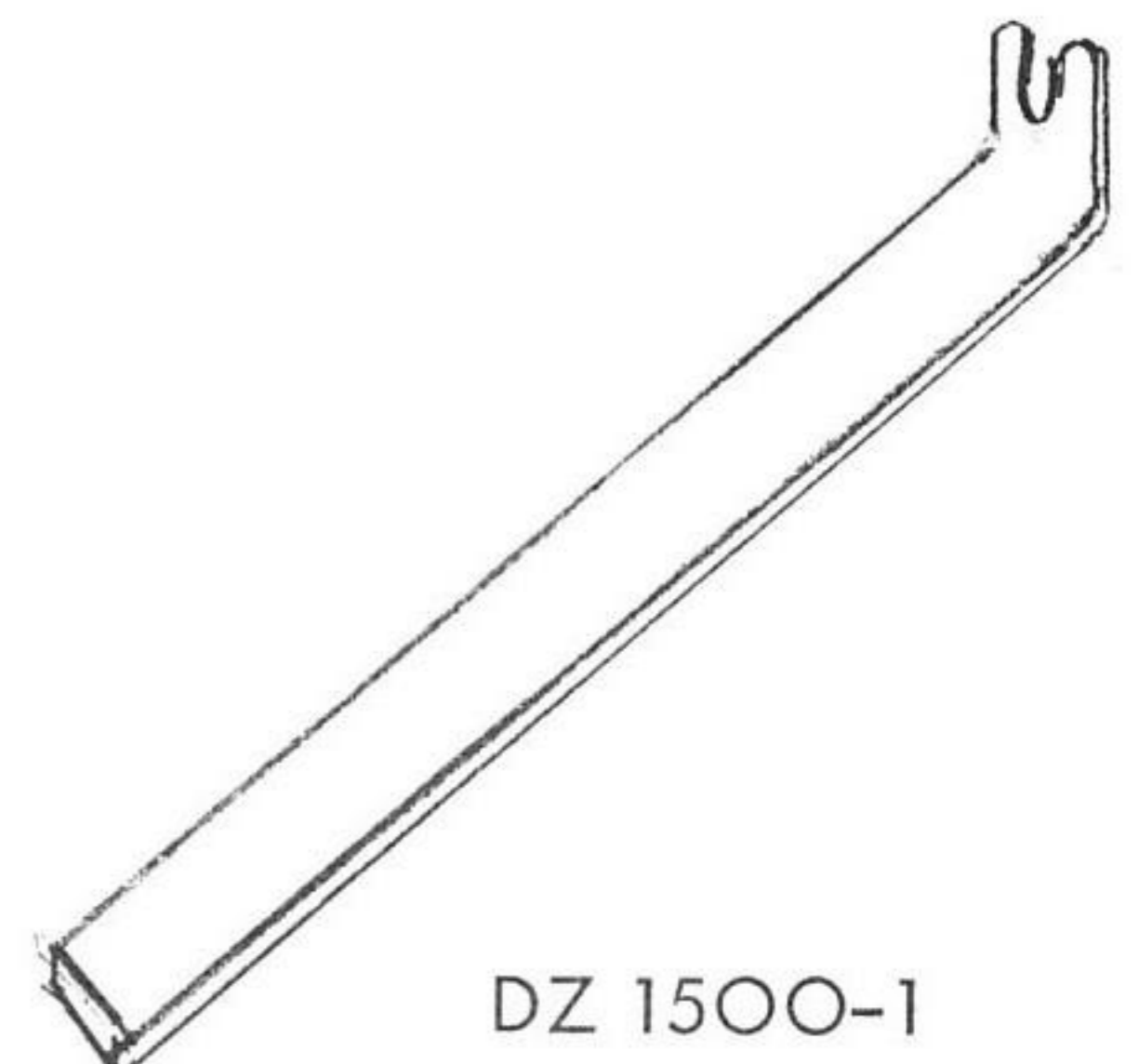

DZ 1500-1

Special TOOLS



US 253

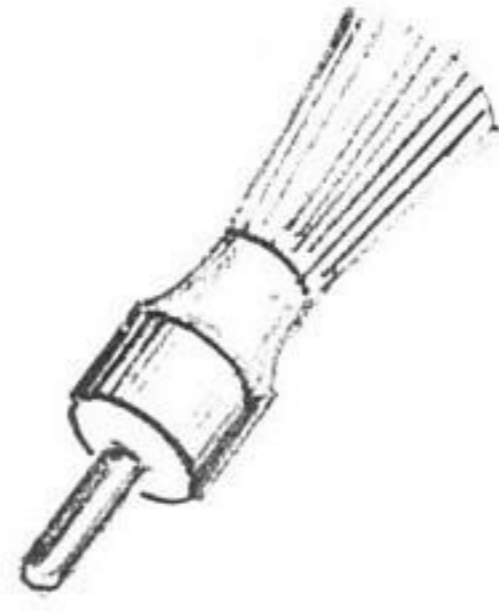

US 311-1



US 311-2



US 311-3

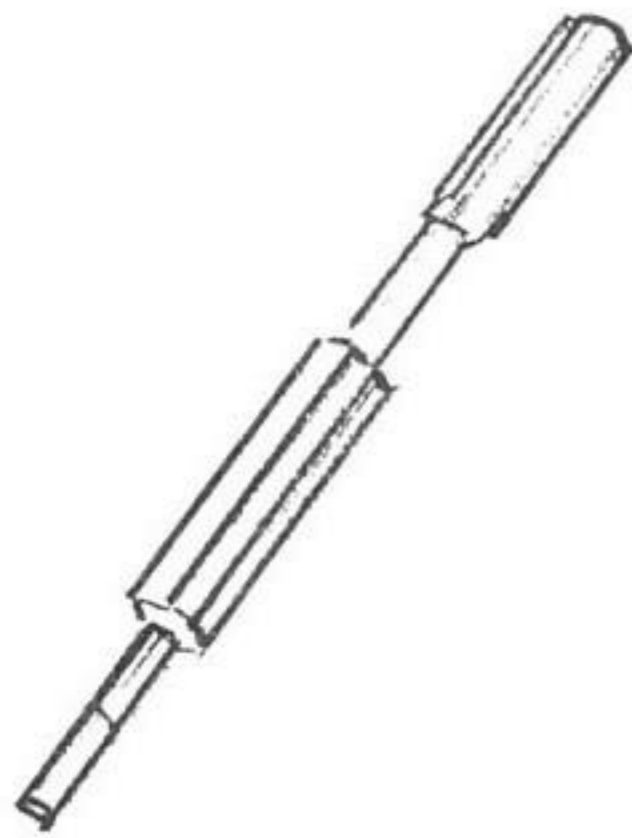

US 253 A



US 311 C

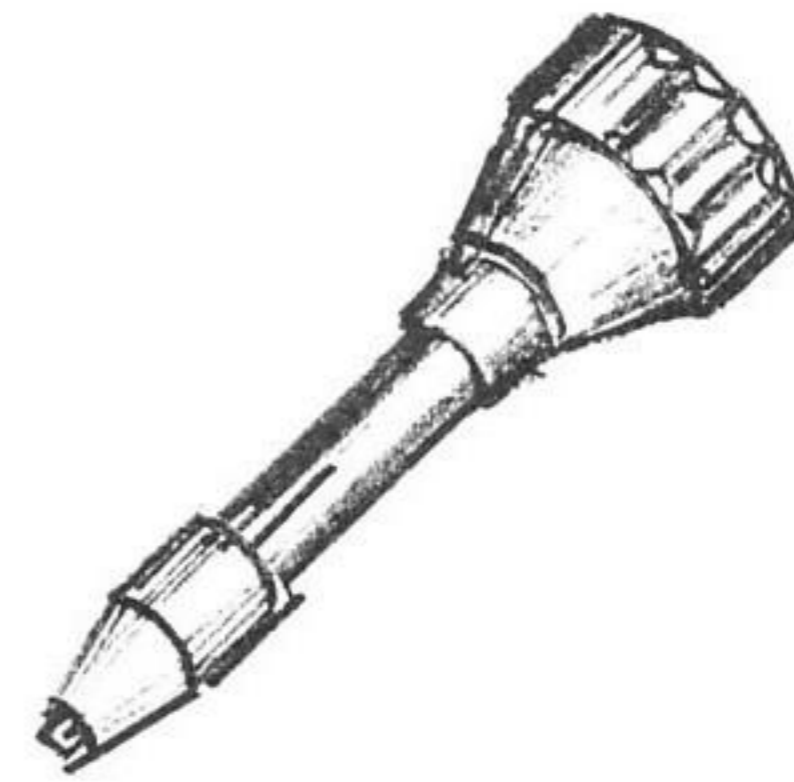

US 311 F

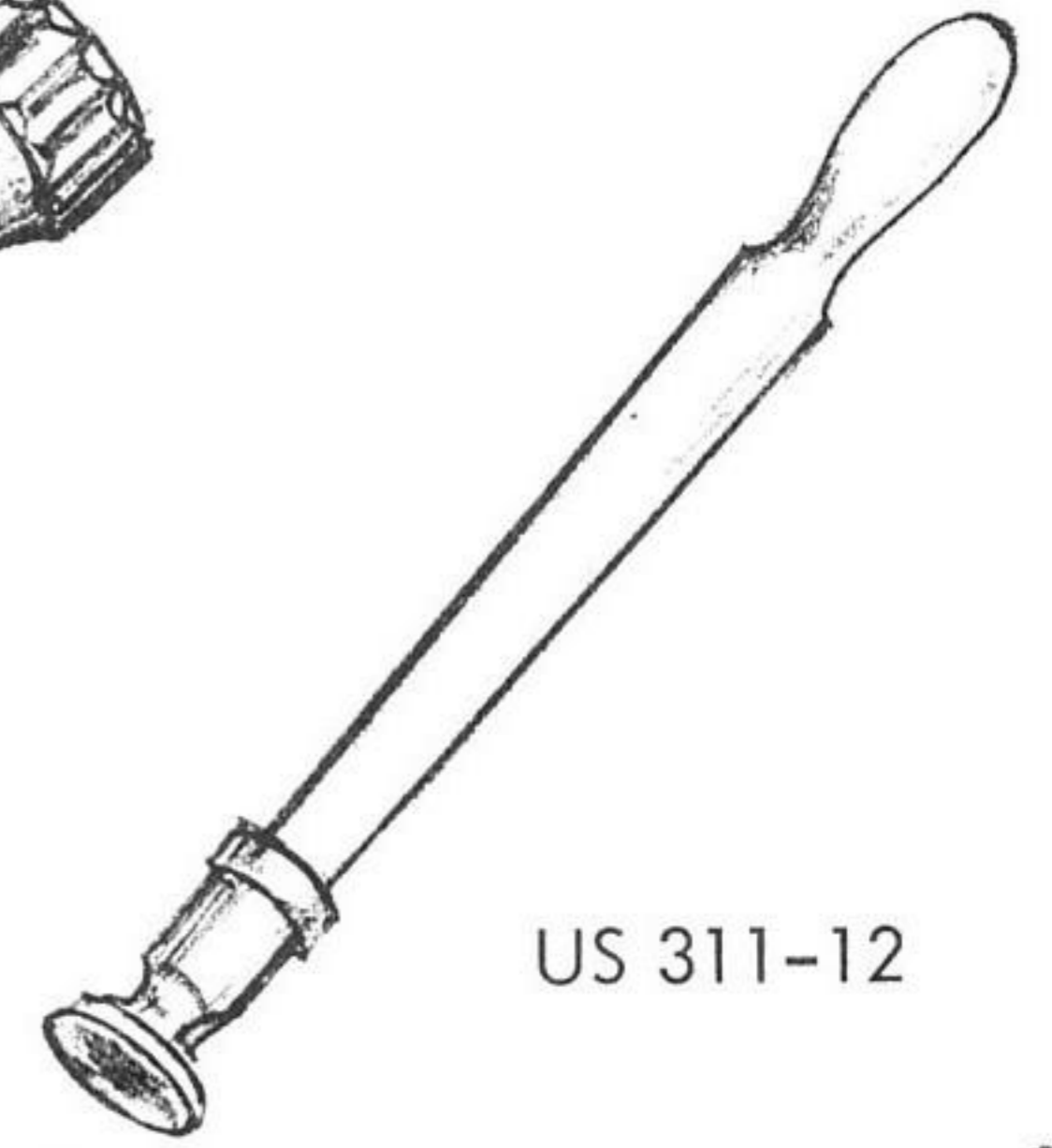

US 311-12



US 311 K-16



US 311K-17



US 311 K-20

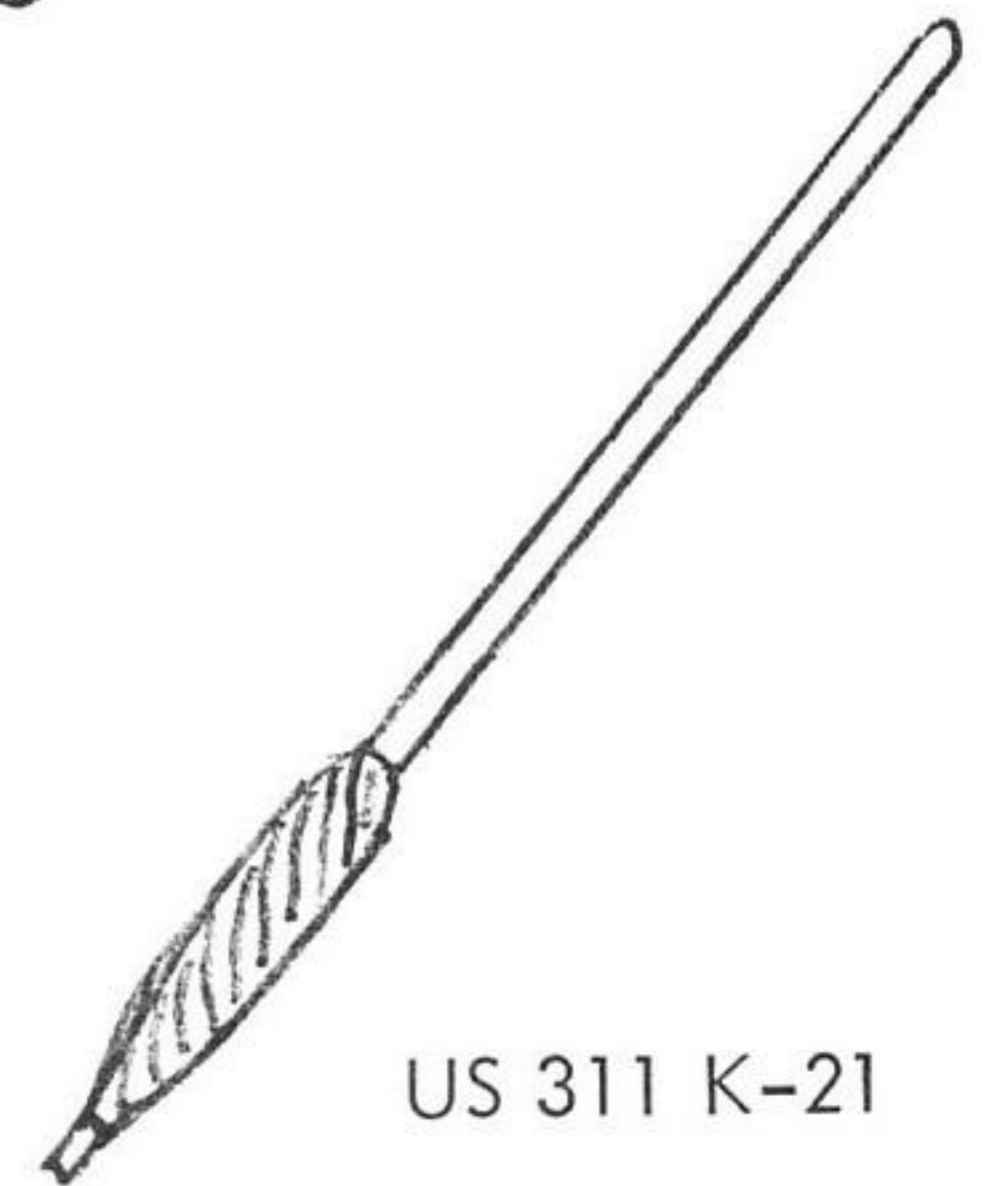

US 311 K-21

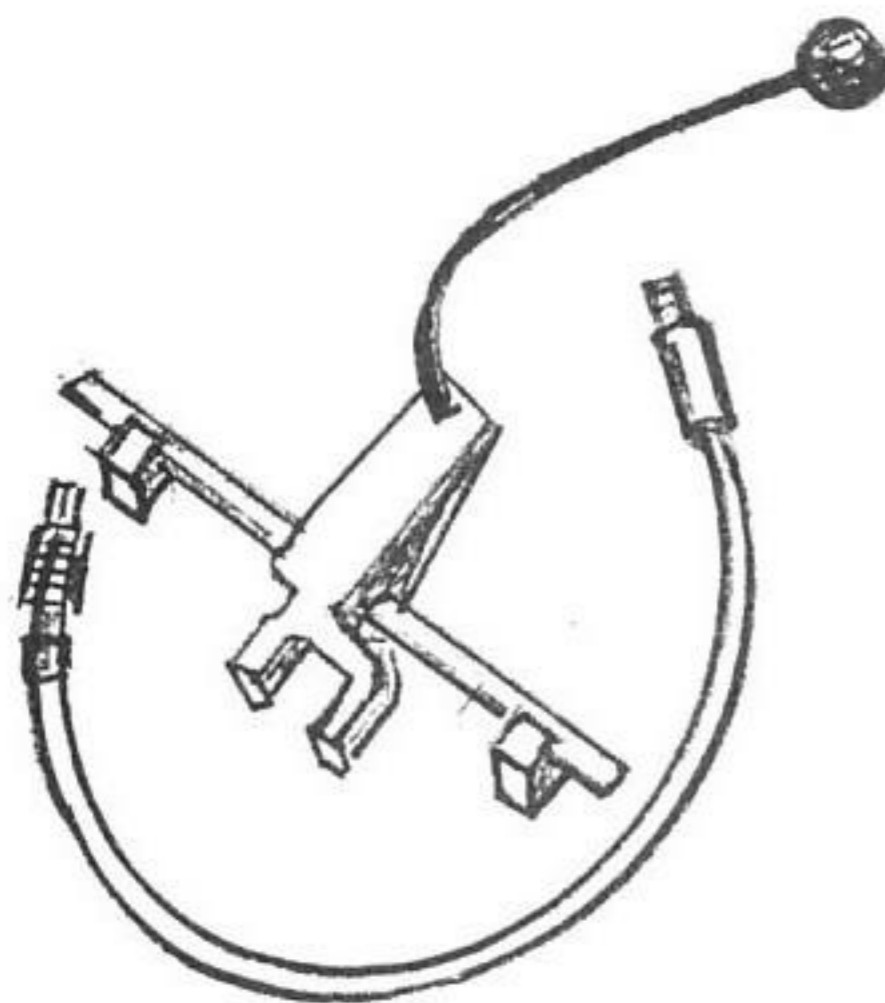

US 653/2

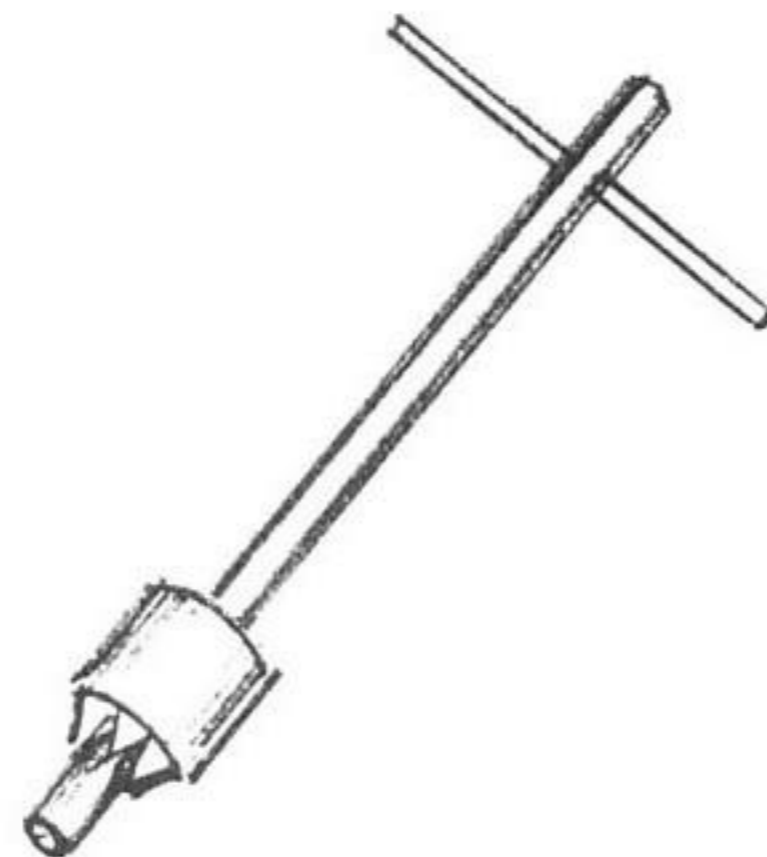

US 699-64

Special **TOOLS**

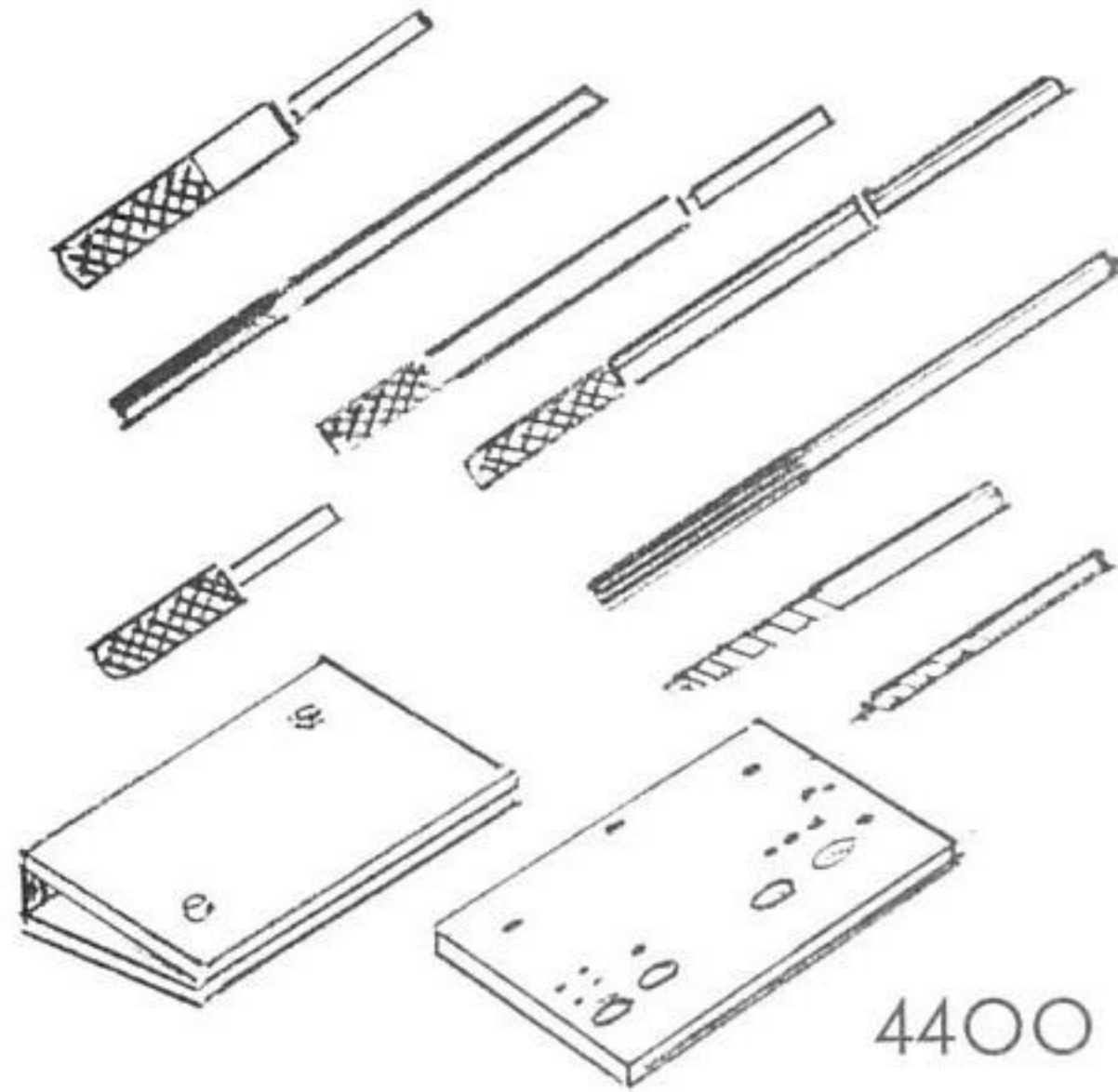

4400

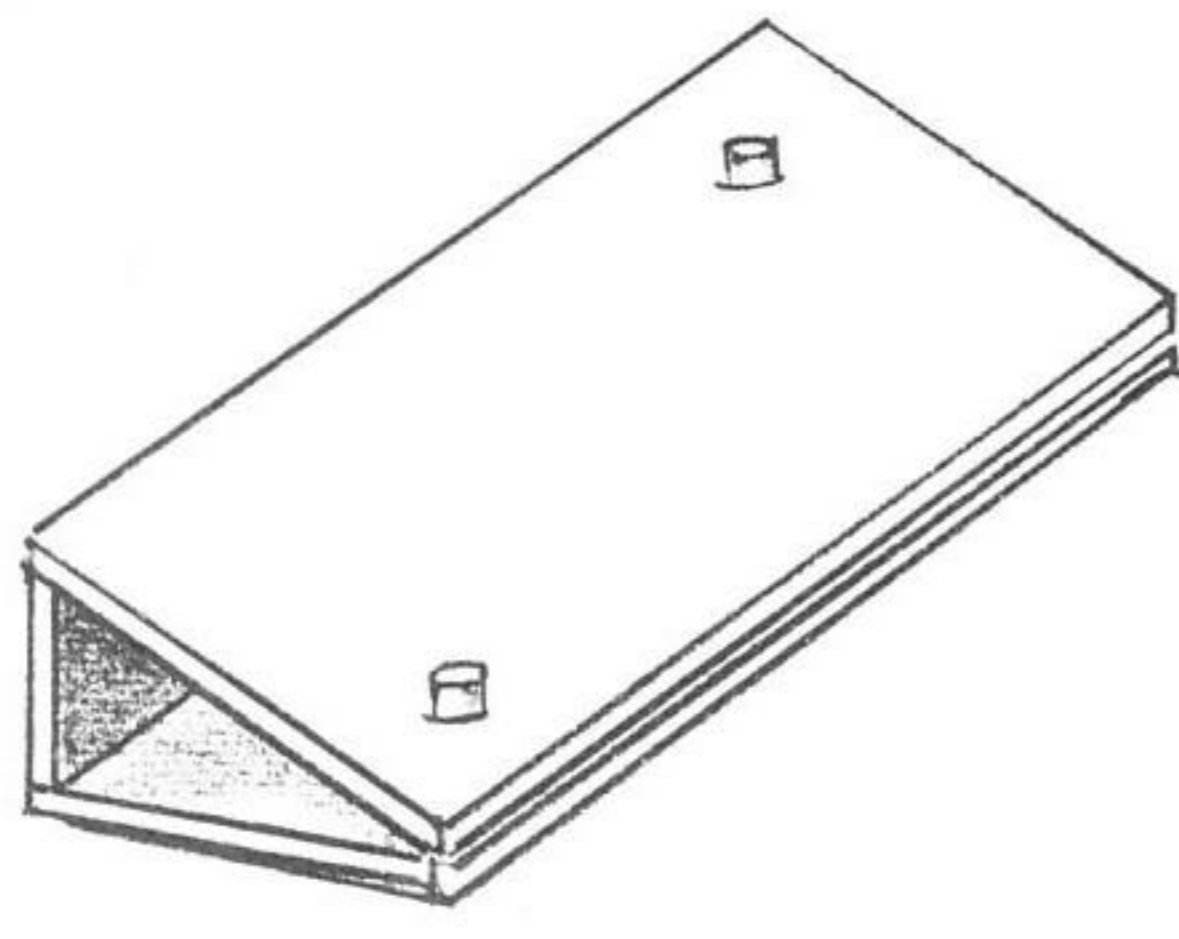

4401

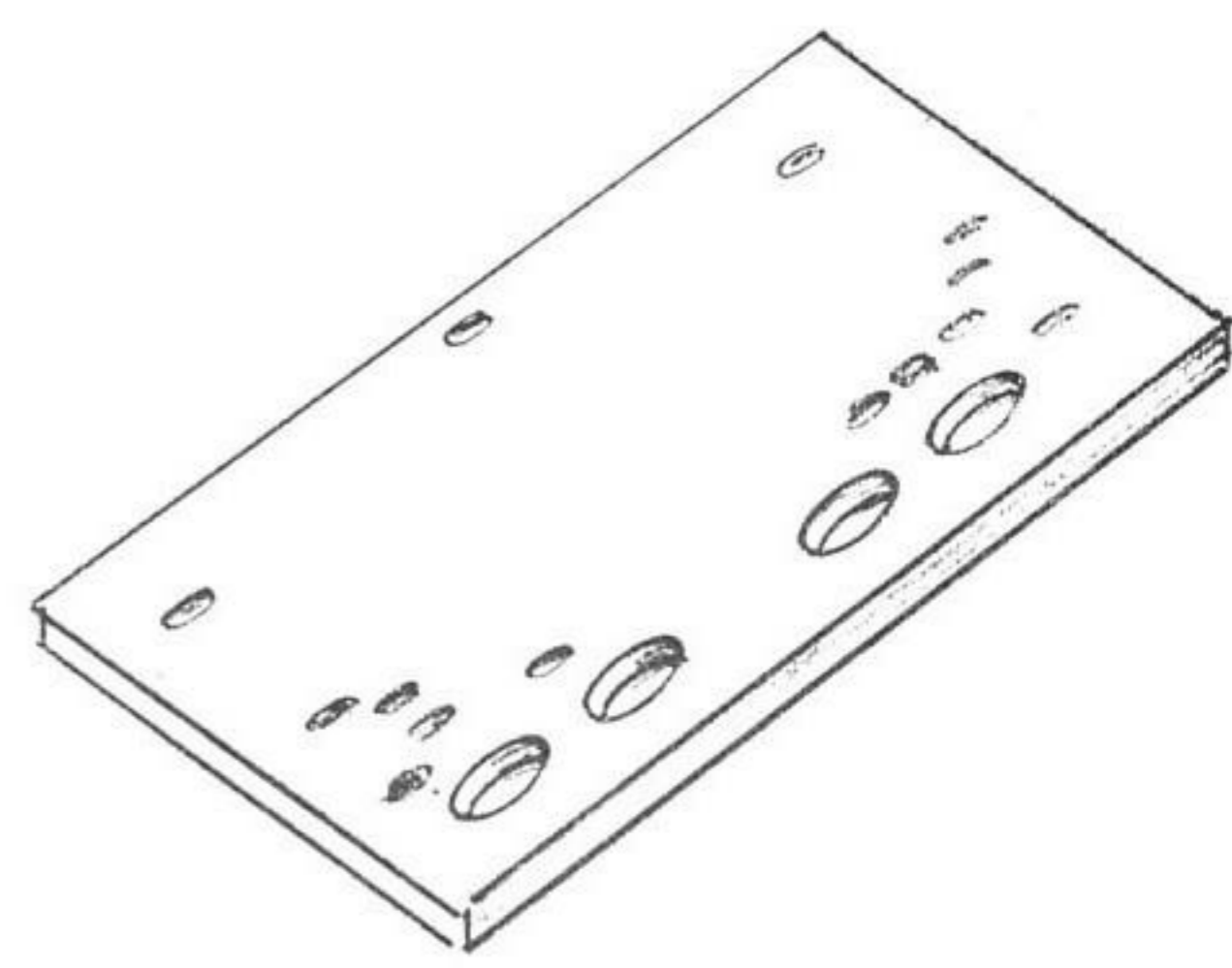

4404

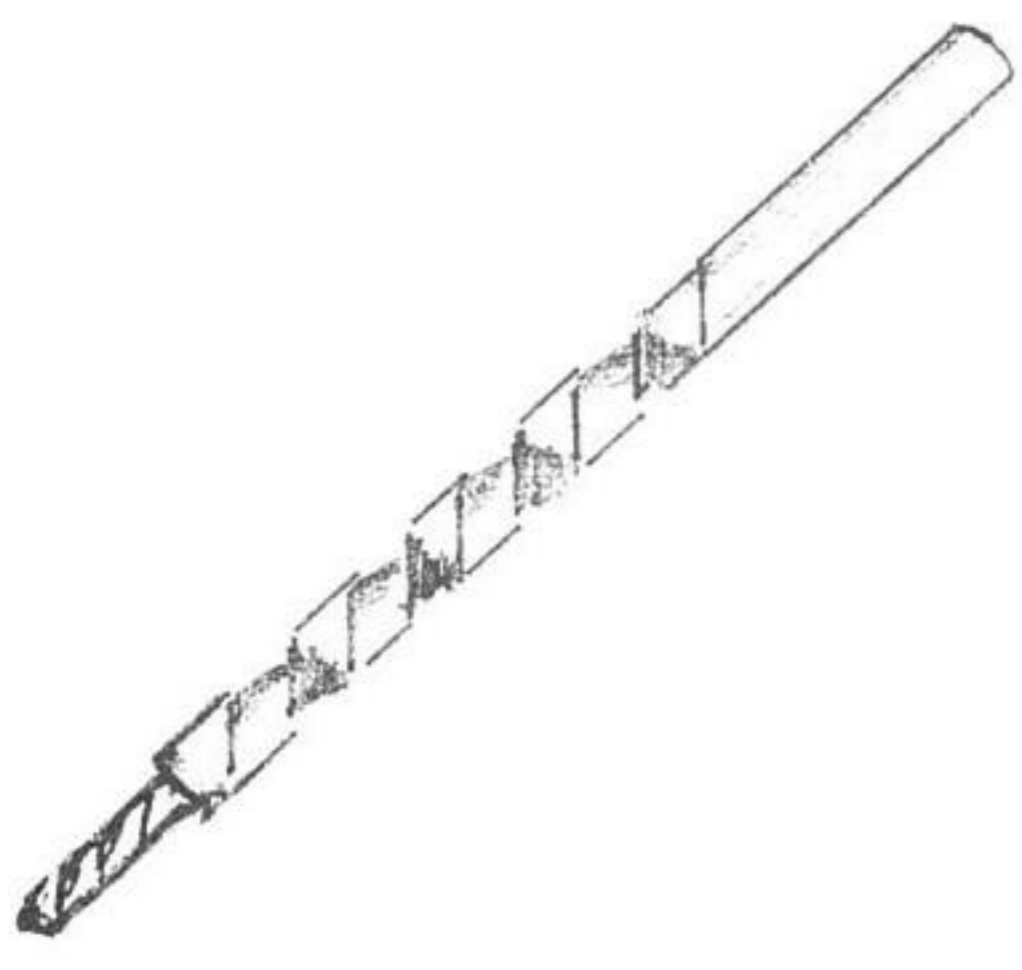

4405



4406



4407



4408



4409

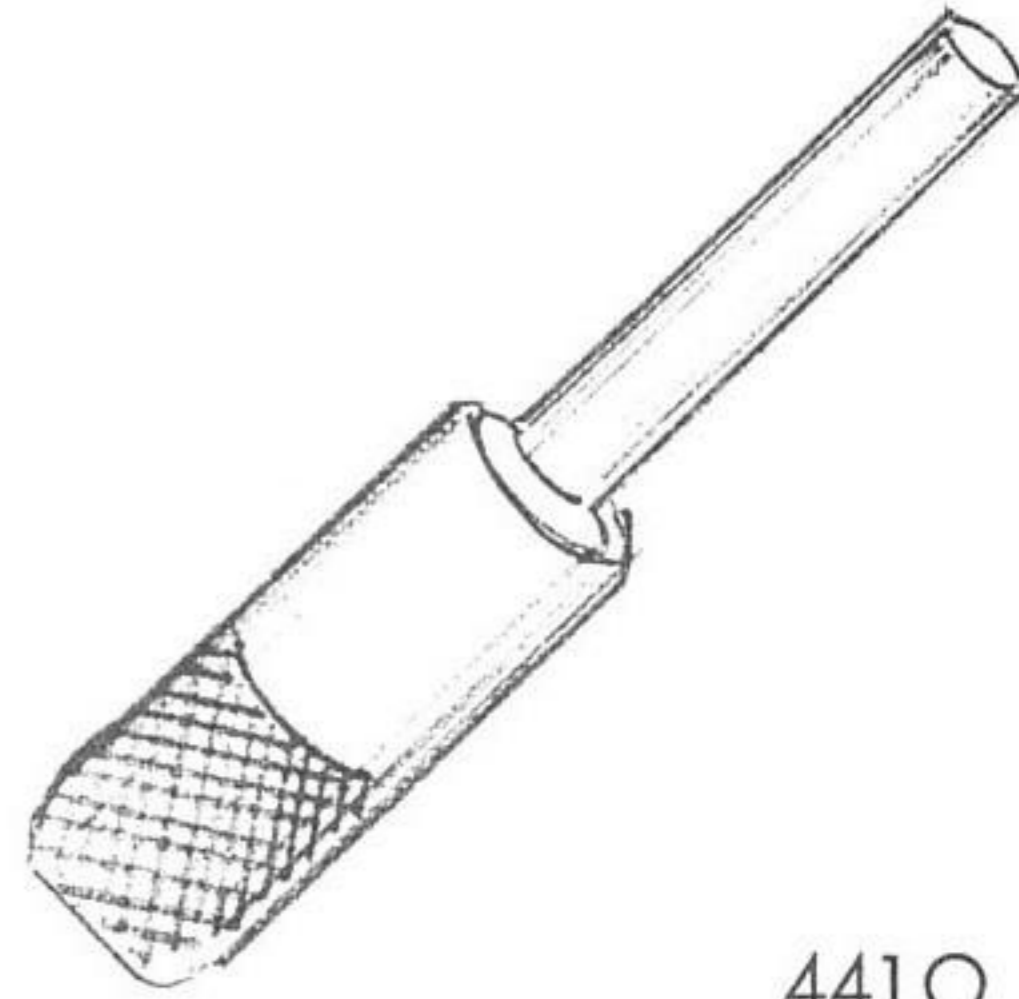

4410



4411

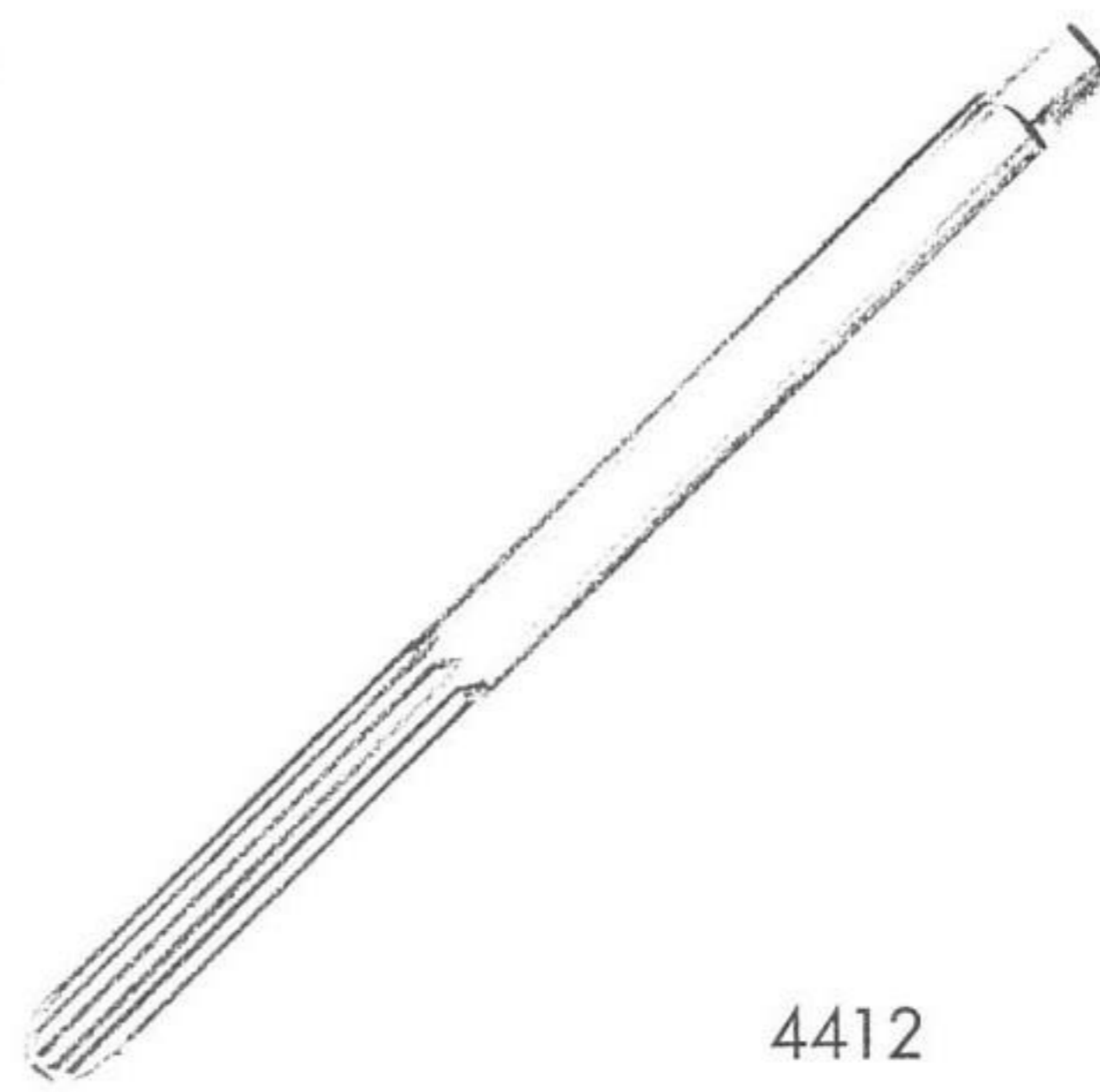

4412

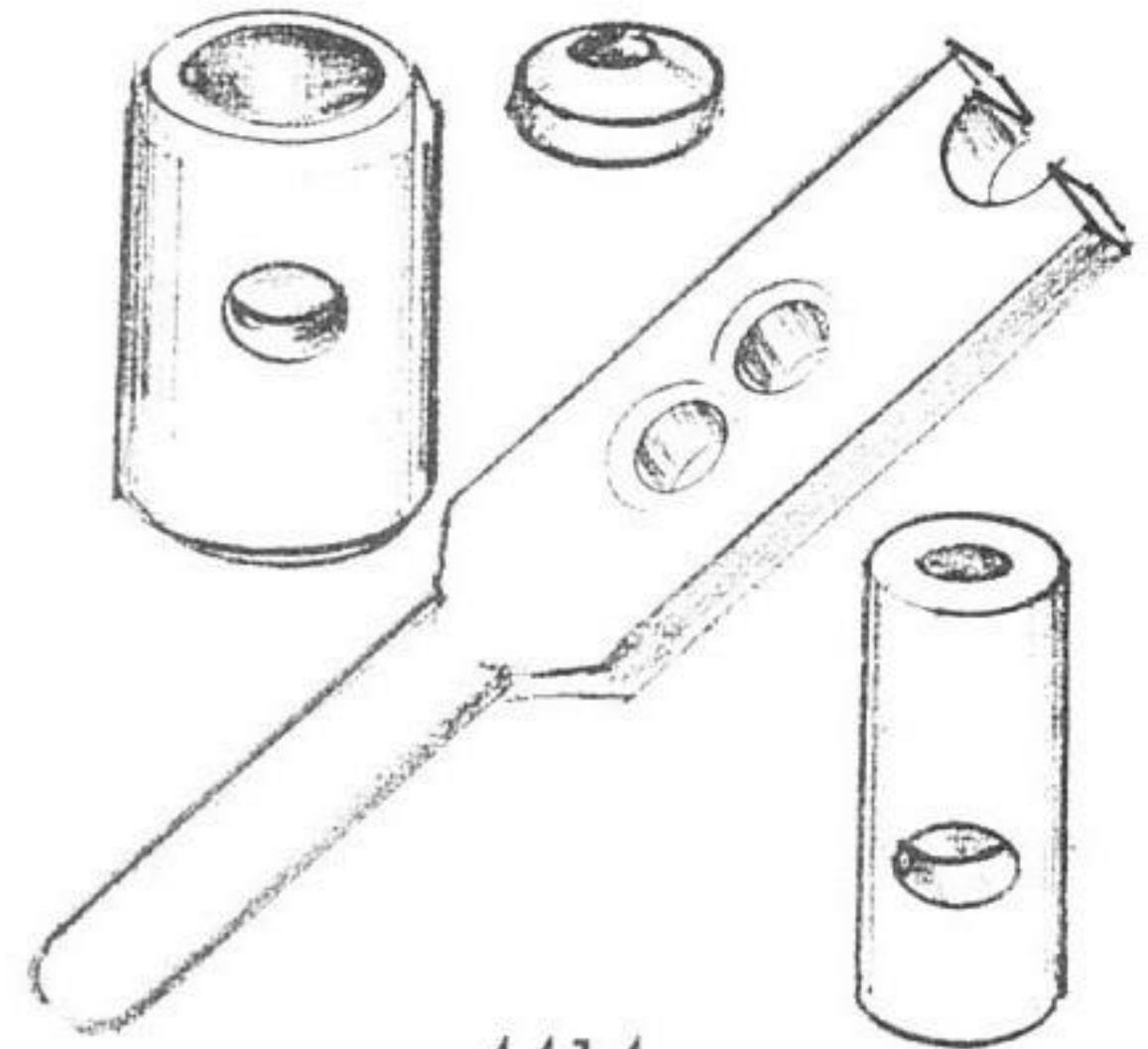

4414

Special TOOLS

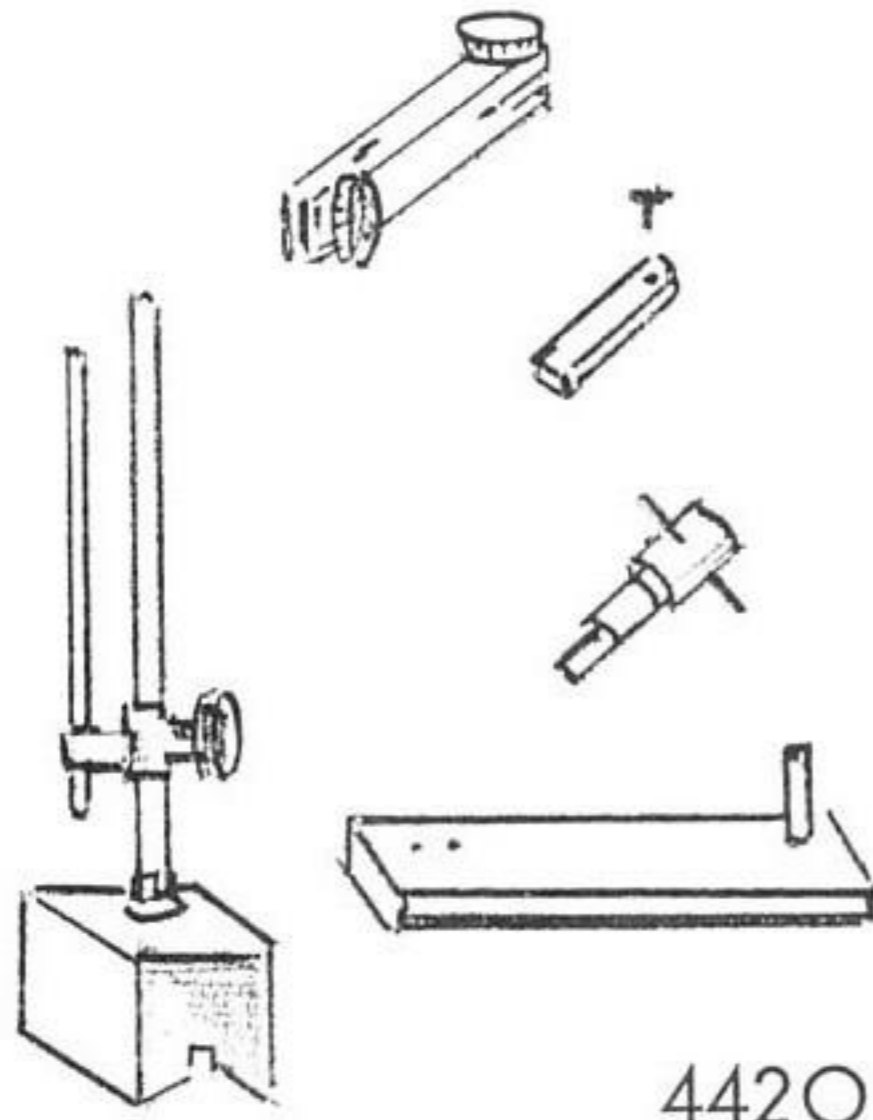

4420

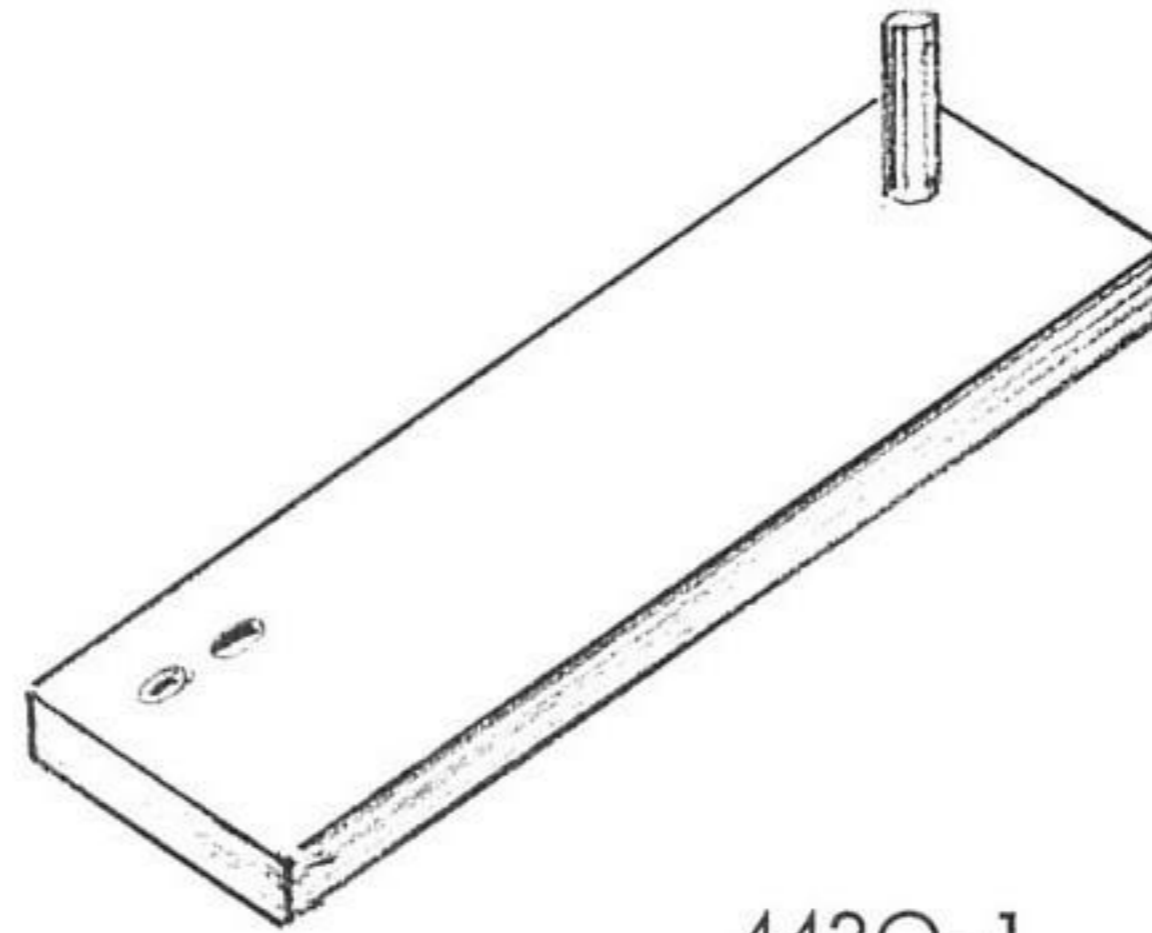

4420-1

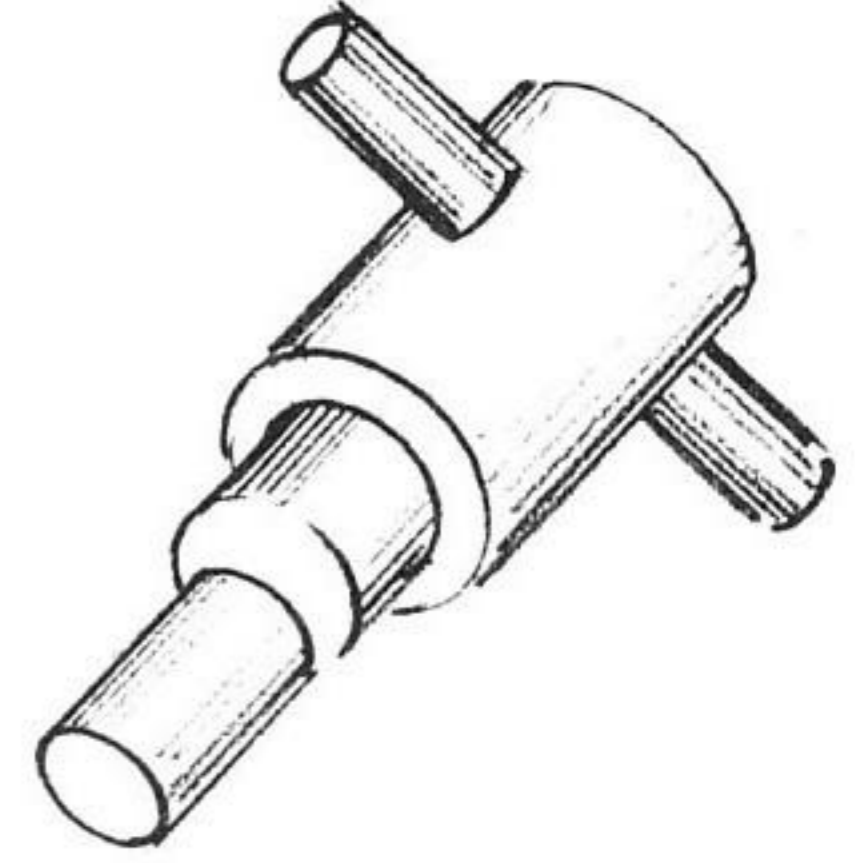

4420-2

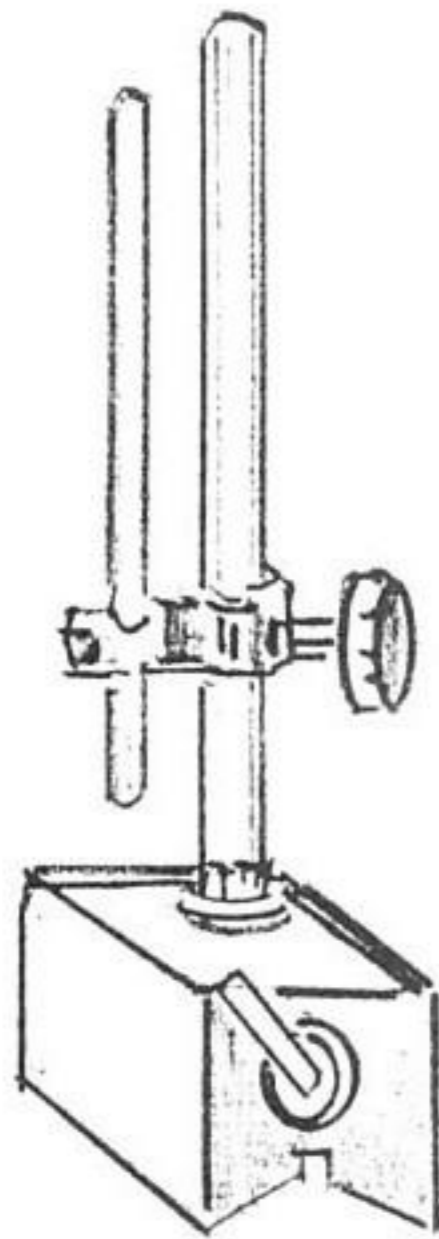

4420-3

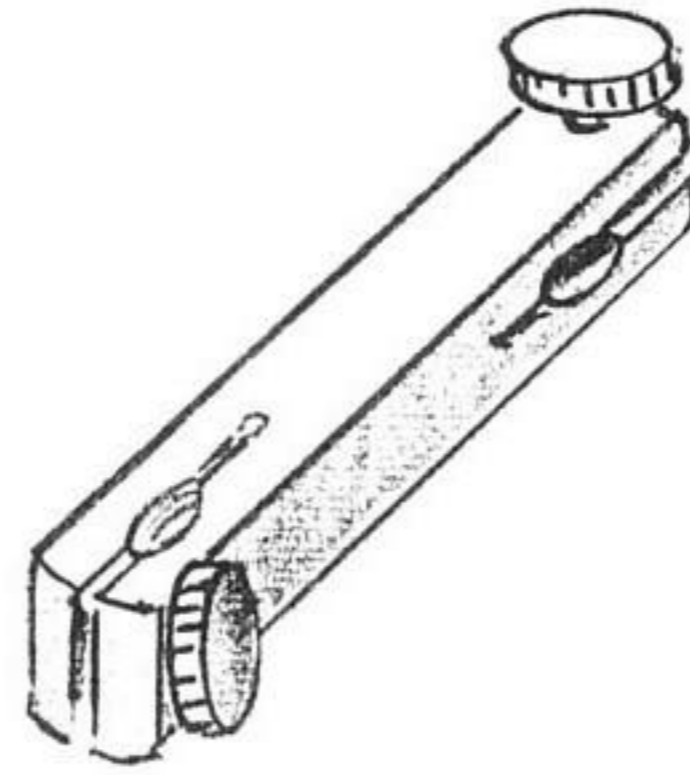

4420-4

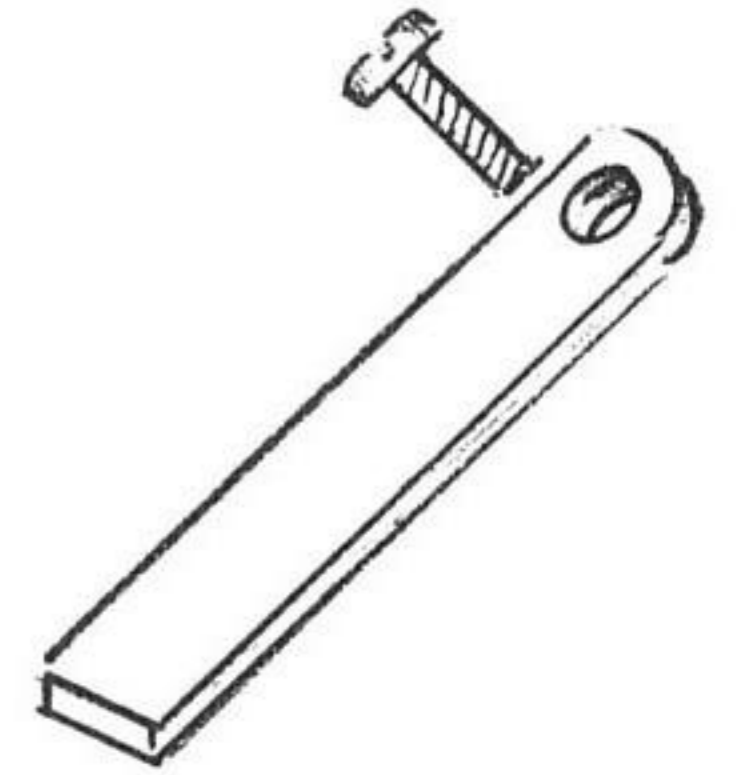

4420-5

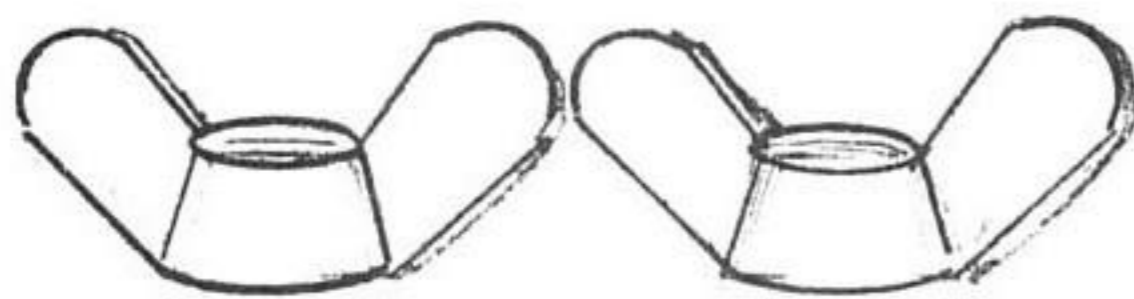

4420-6

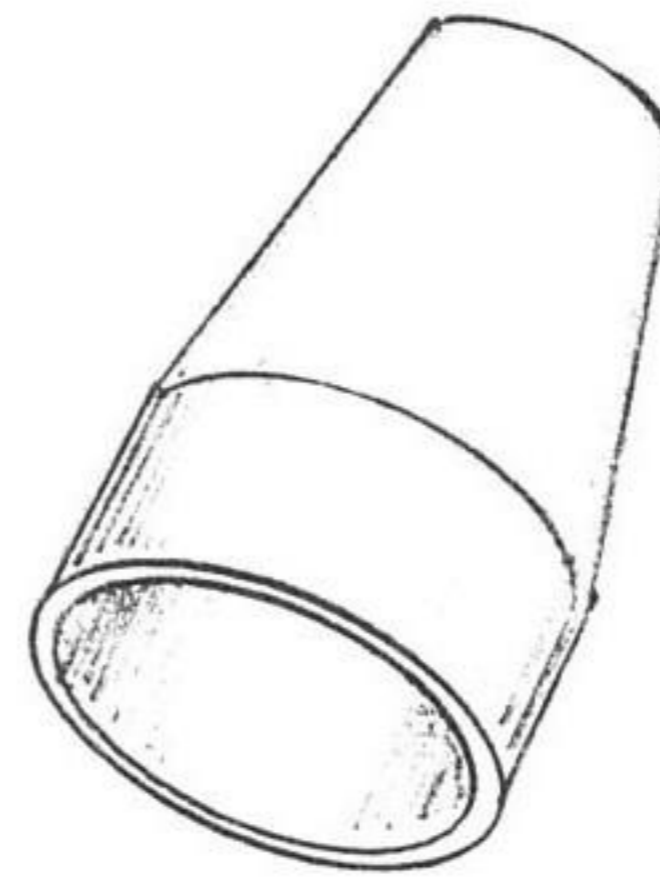

4427

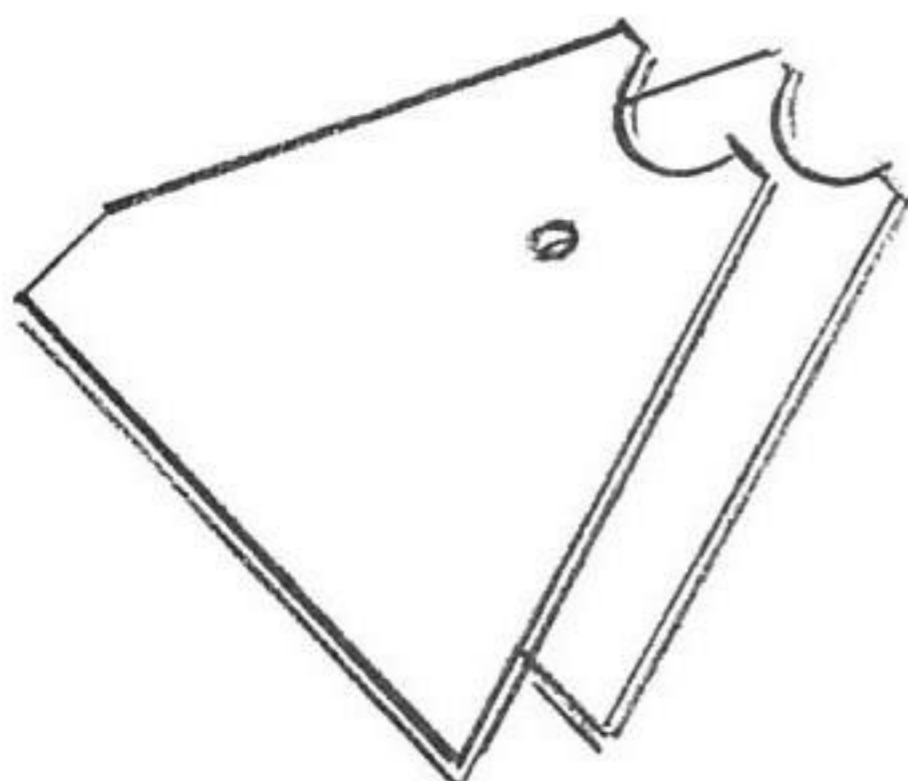

4421
4423

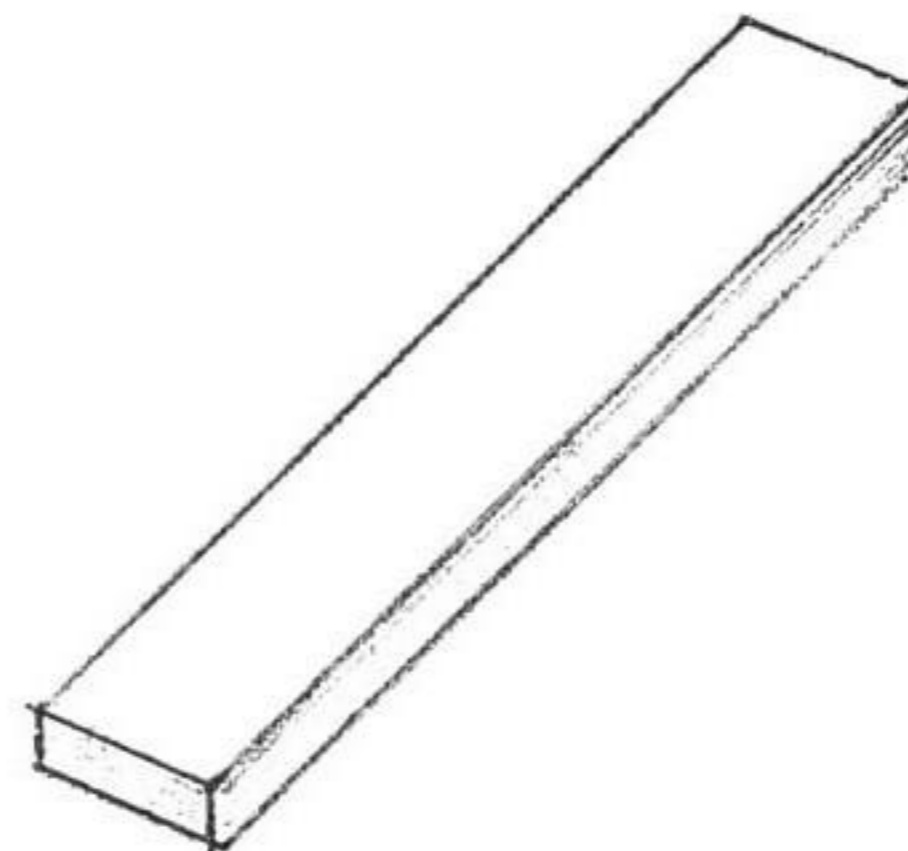

4424

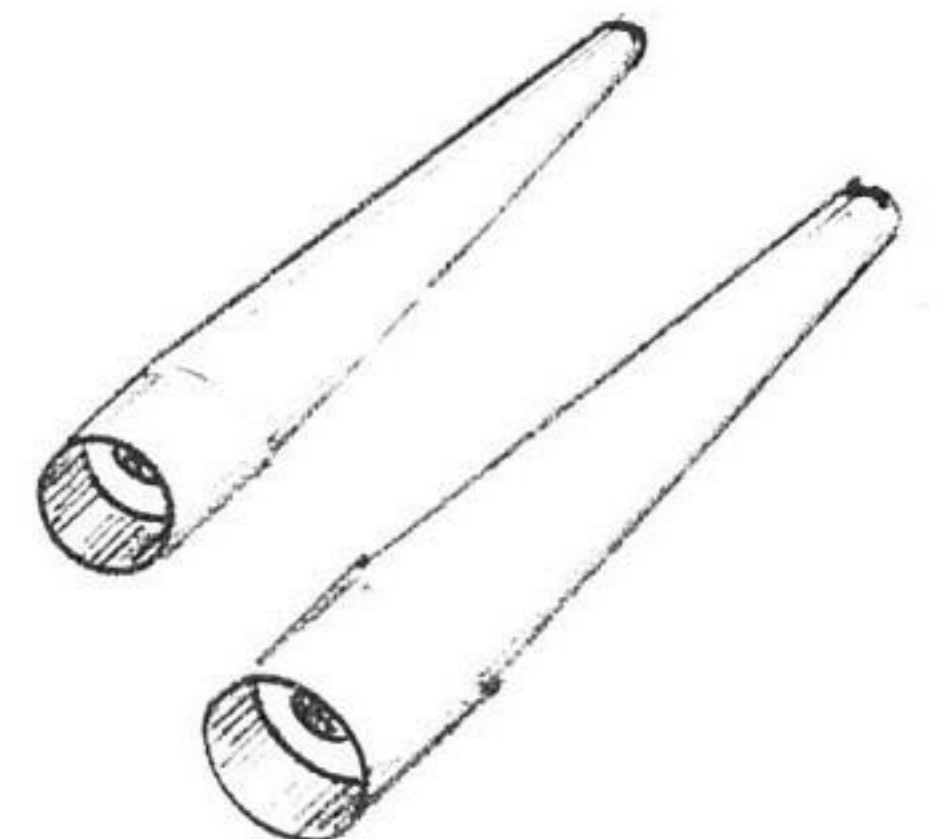

4425
4426

Special TOOLS

FRAME JIG

US 4430

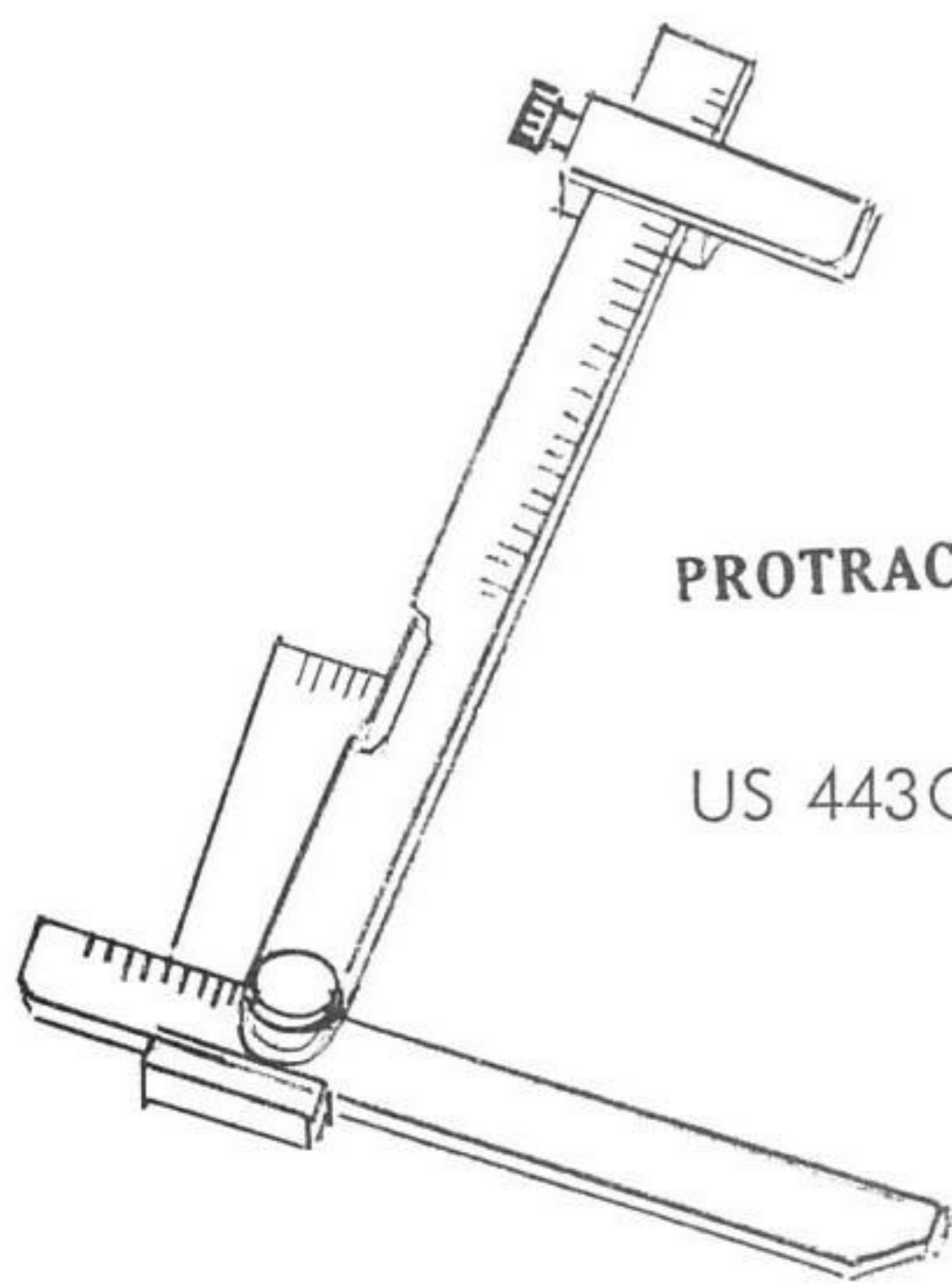
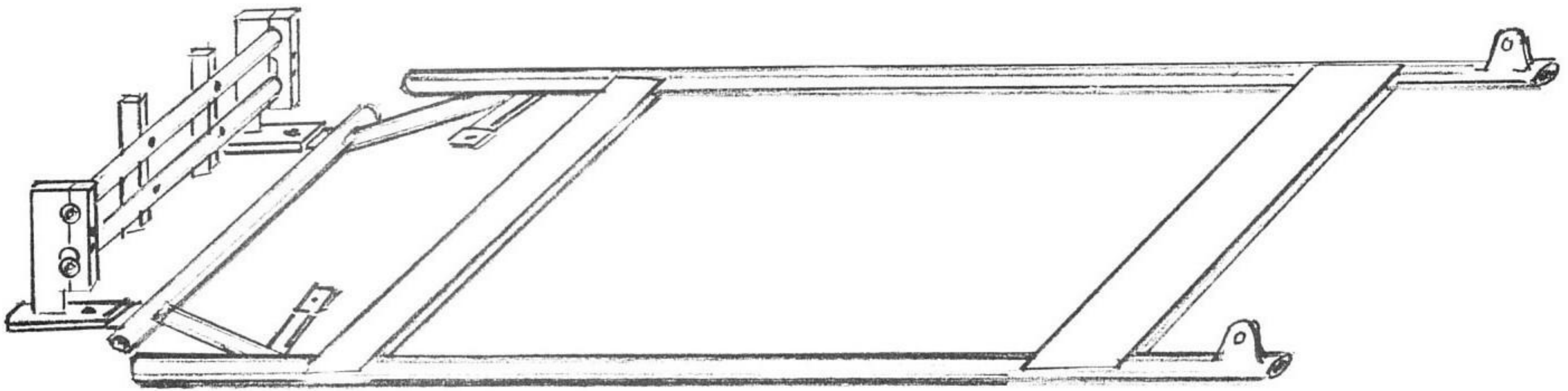

PROTRACTOR

US 4430-5

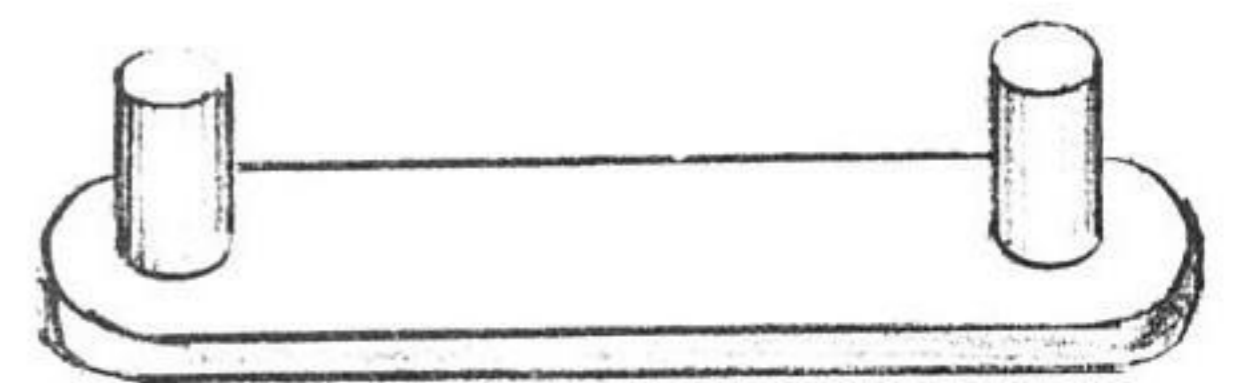

US 4431

CHECKING TOOLS
FOR AUTOMATIC TRANSMISSION

4 PIECES

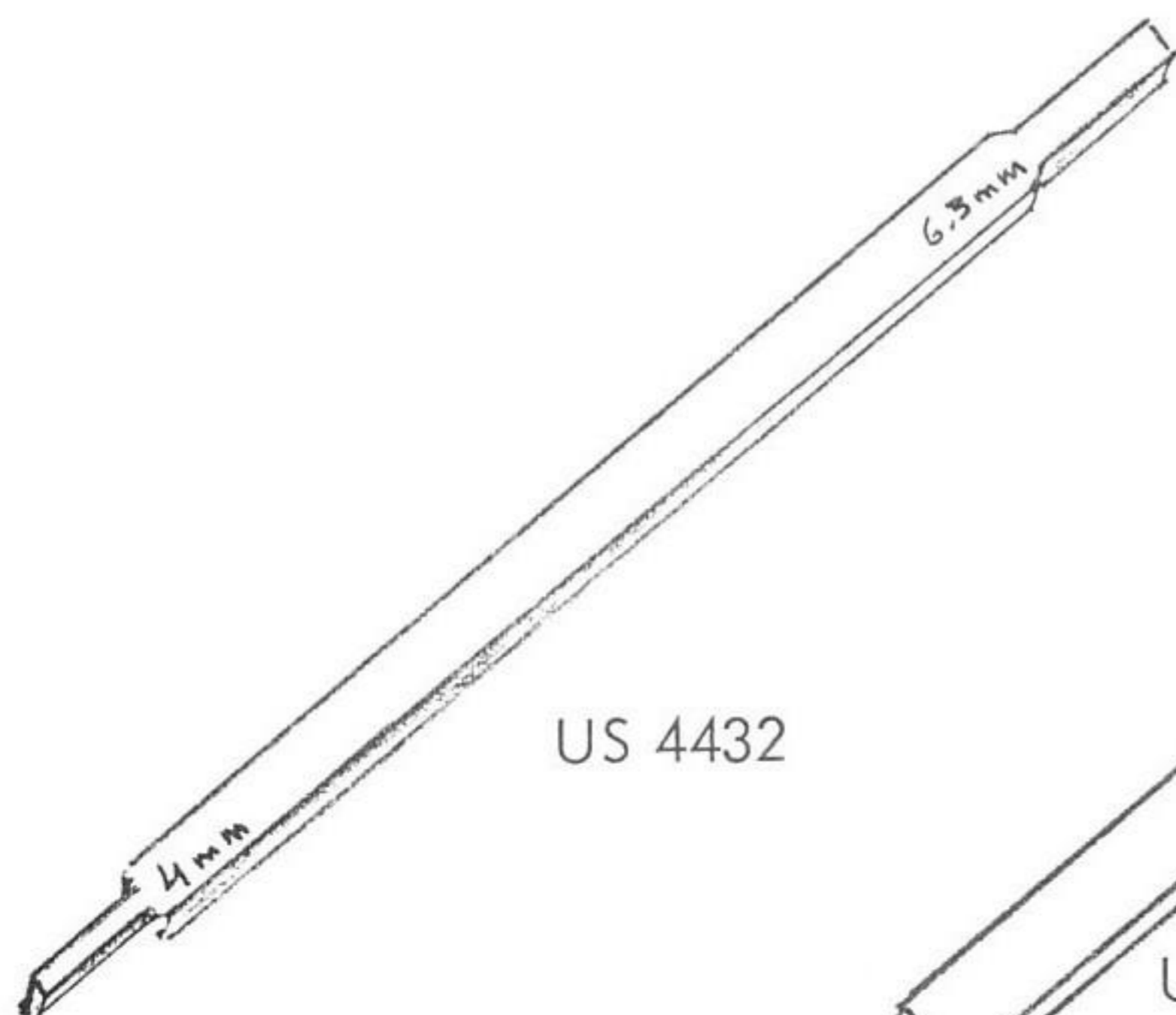

US 4432

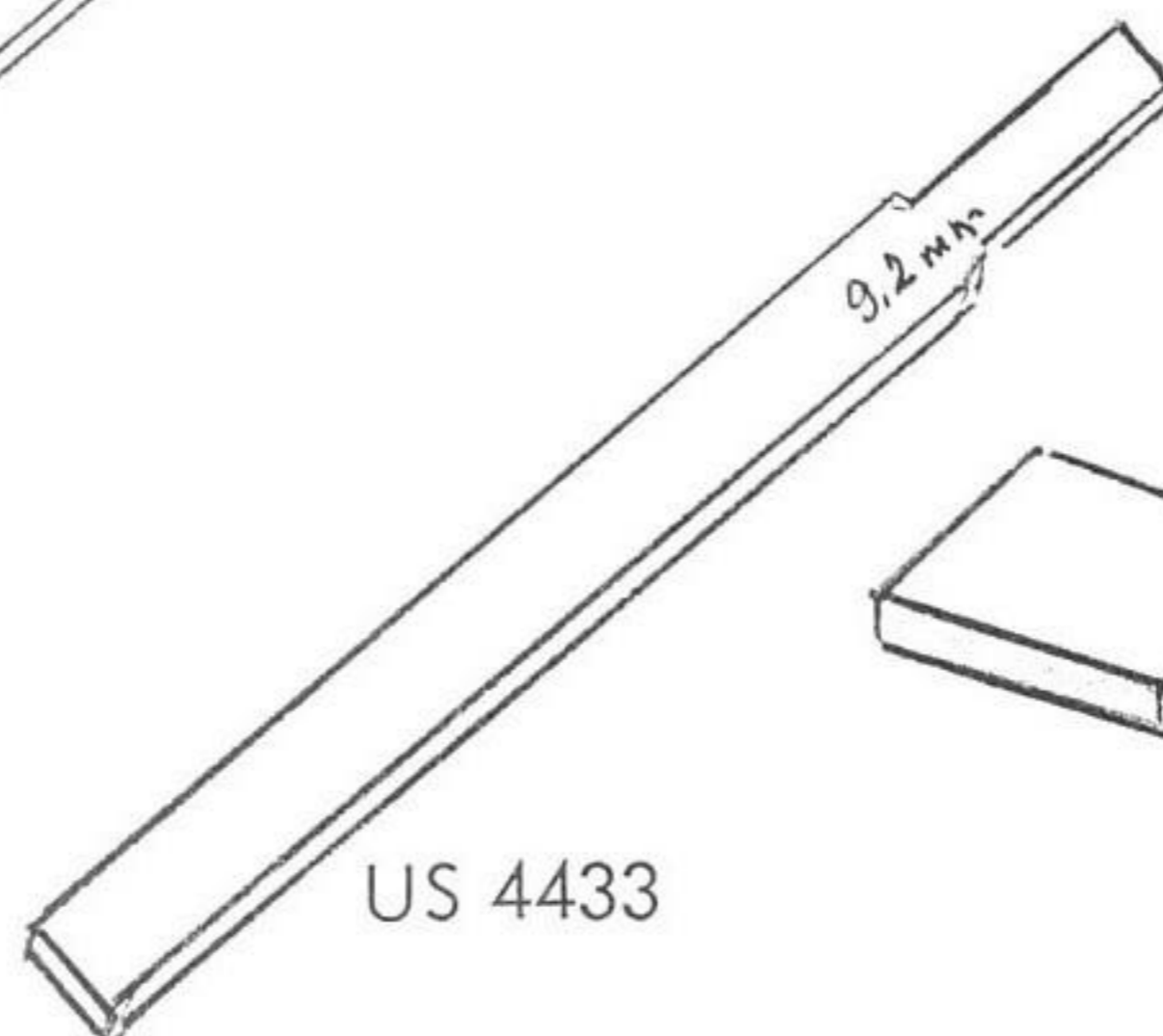

US 4433

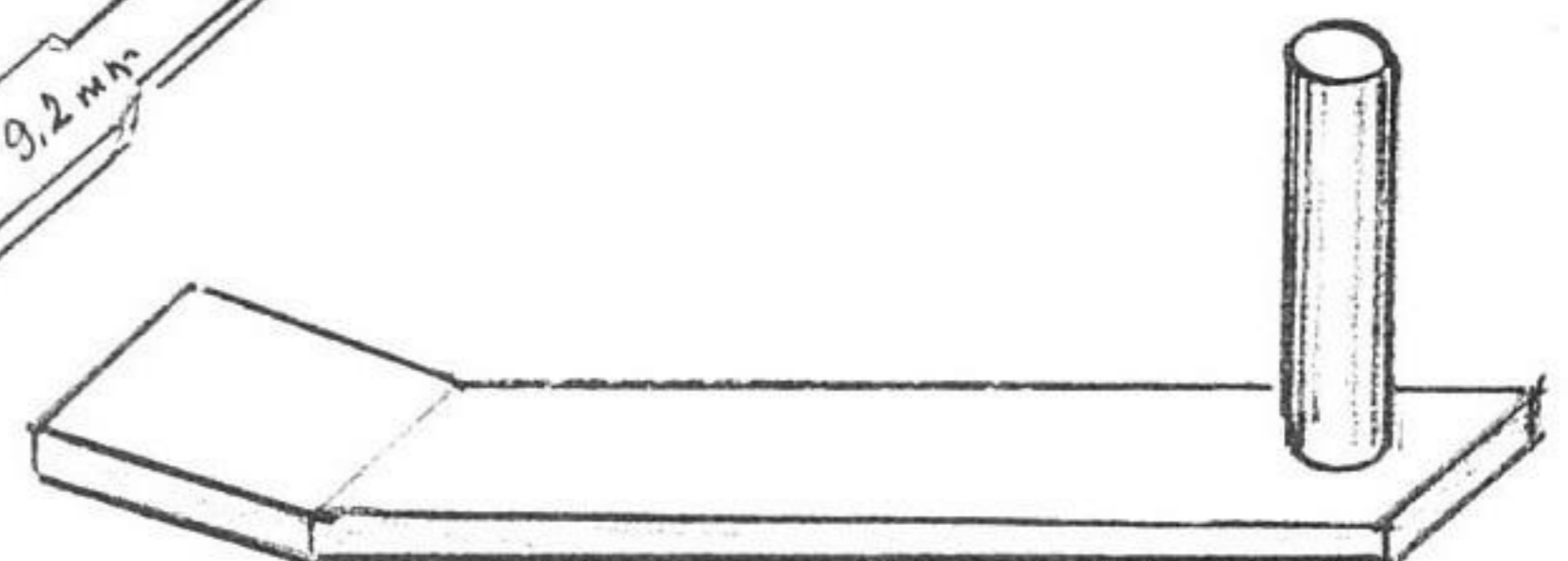

US 4434

Special TOOLS



2502

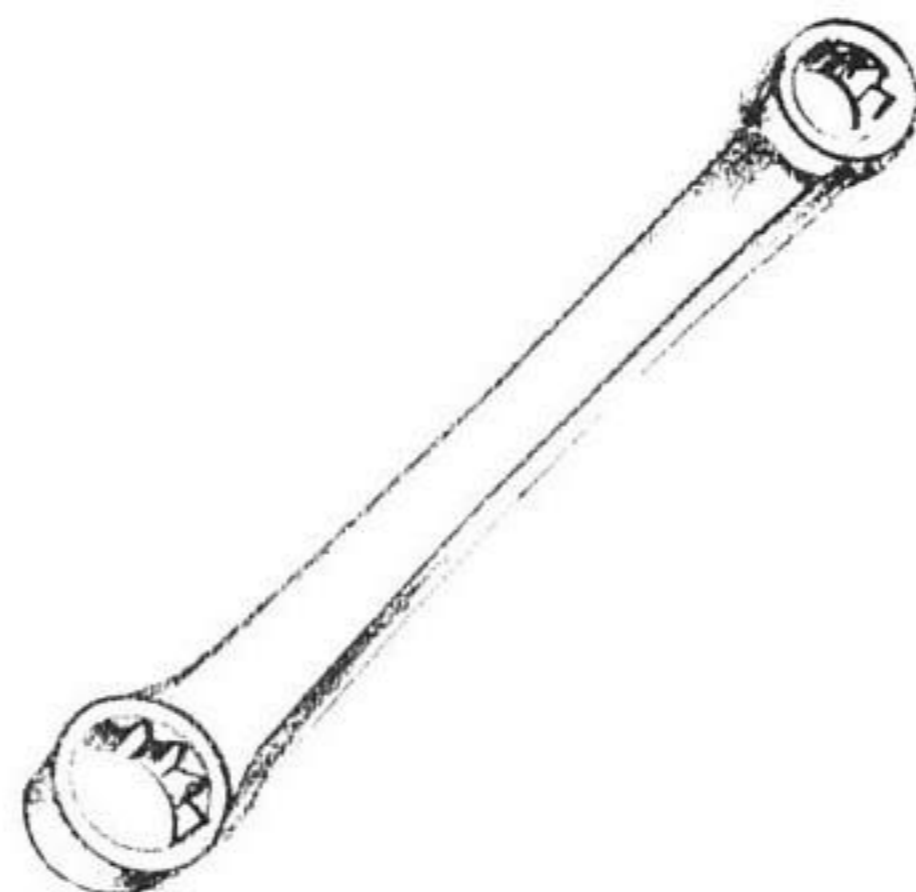

2560



2561

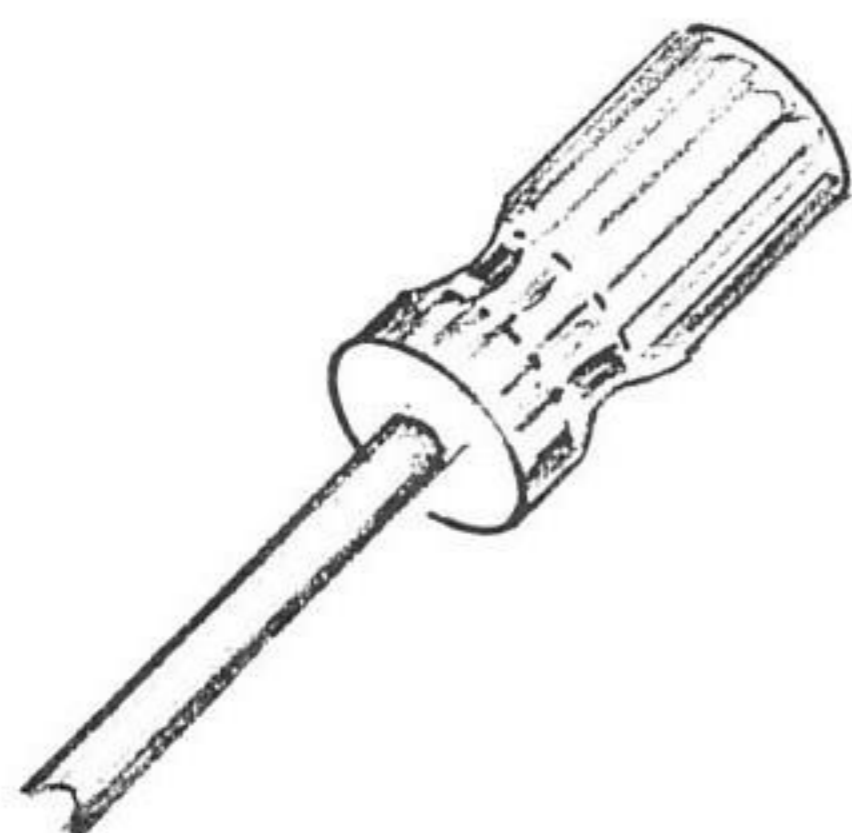

2566



2567

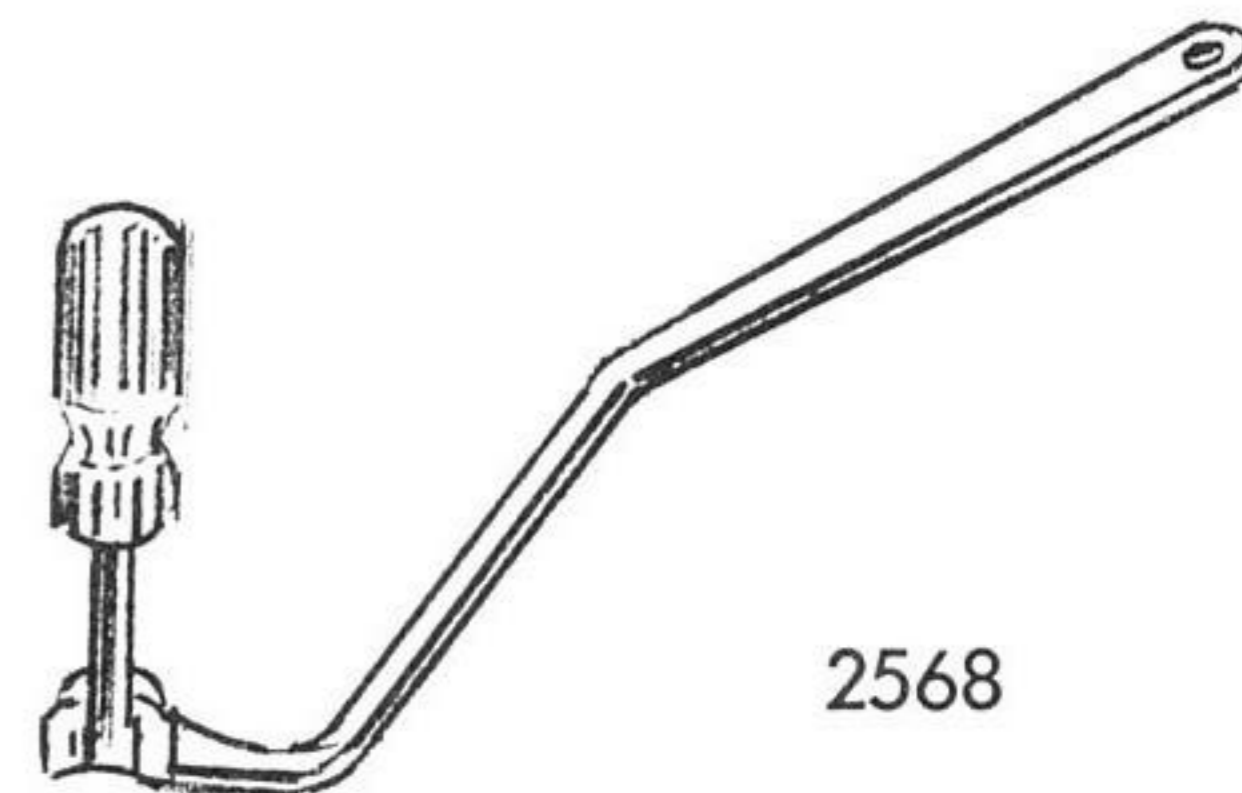

2568

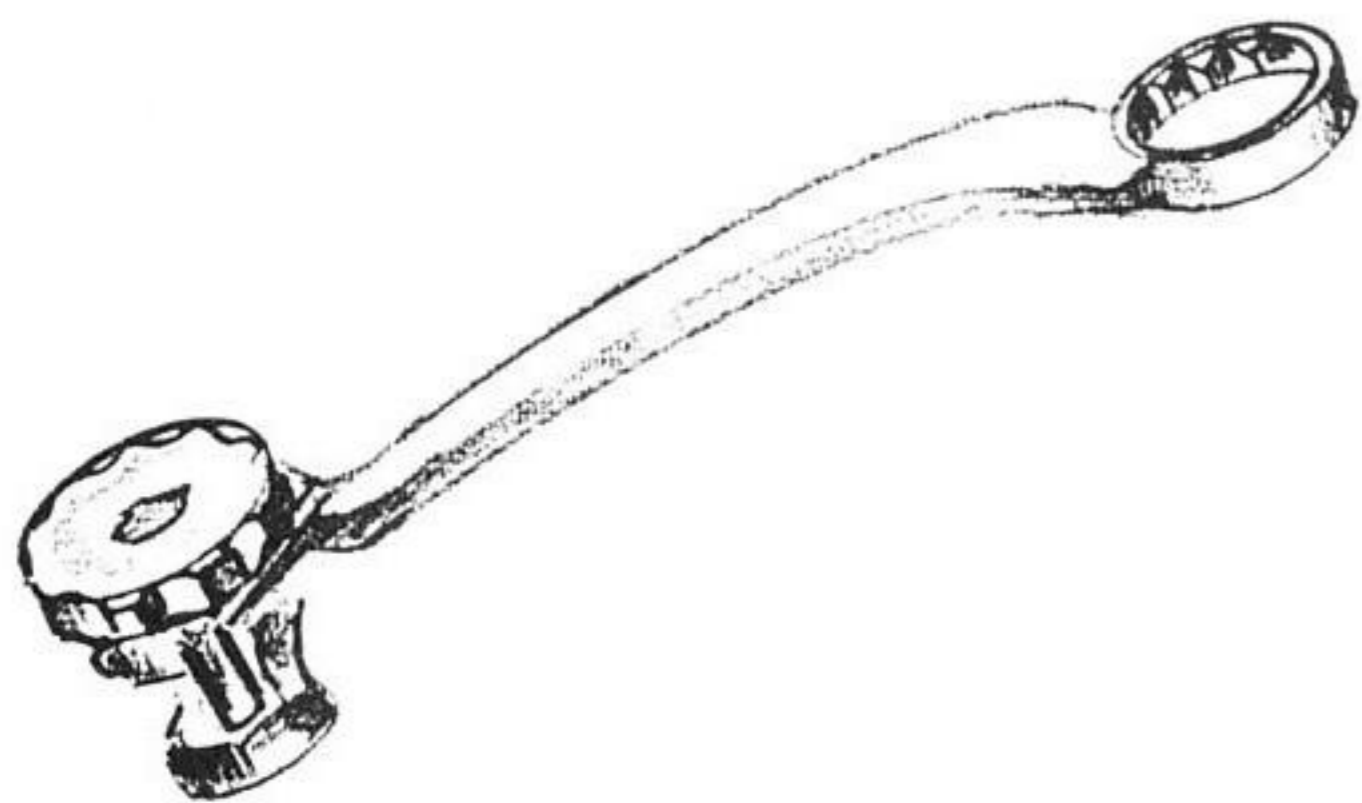

2569



2578

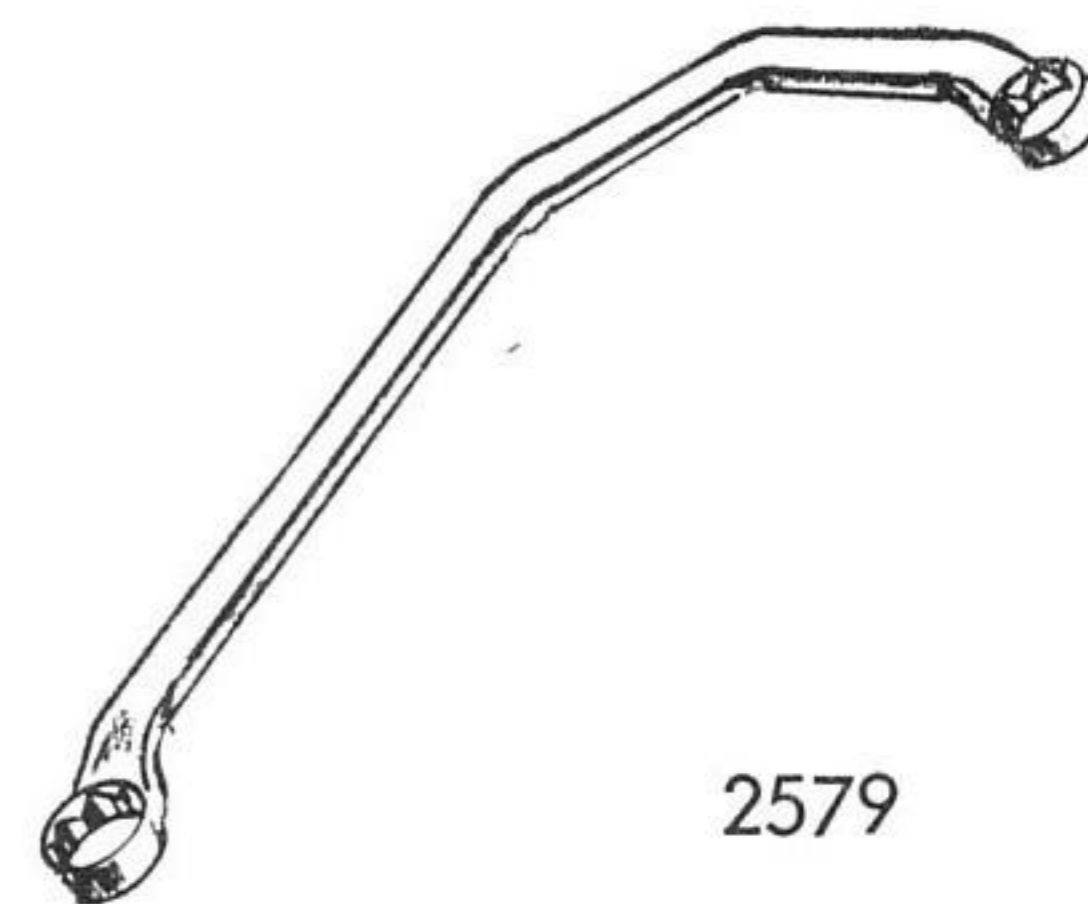

2579

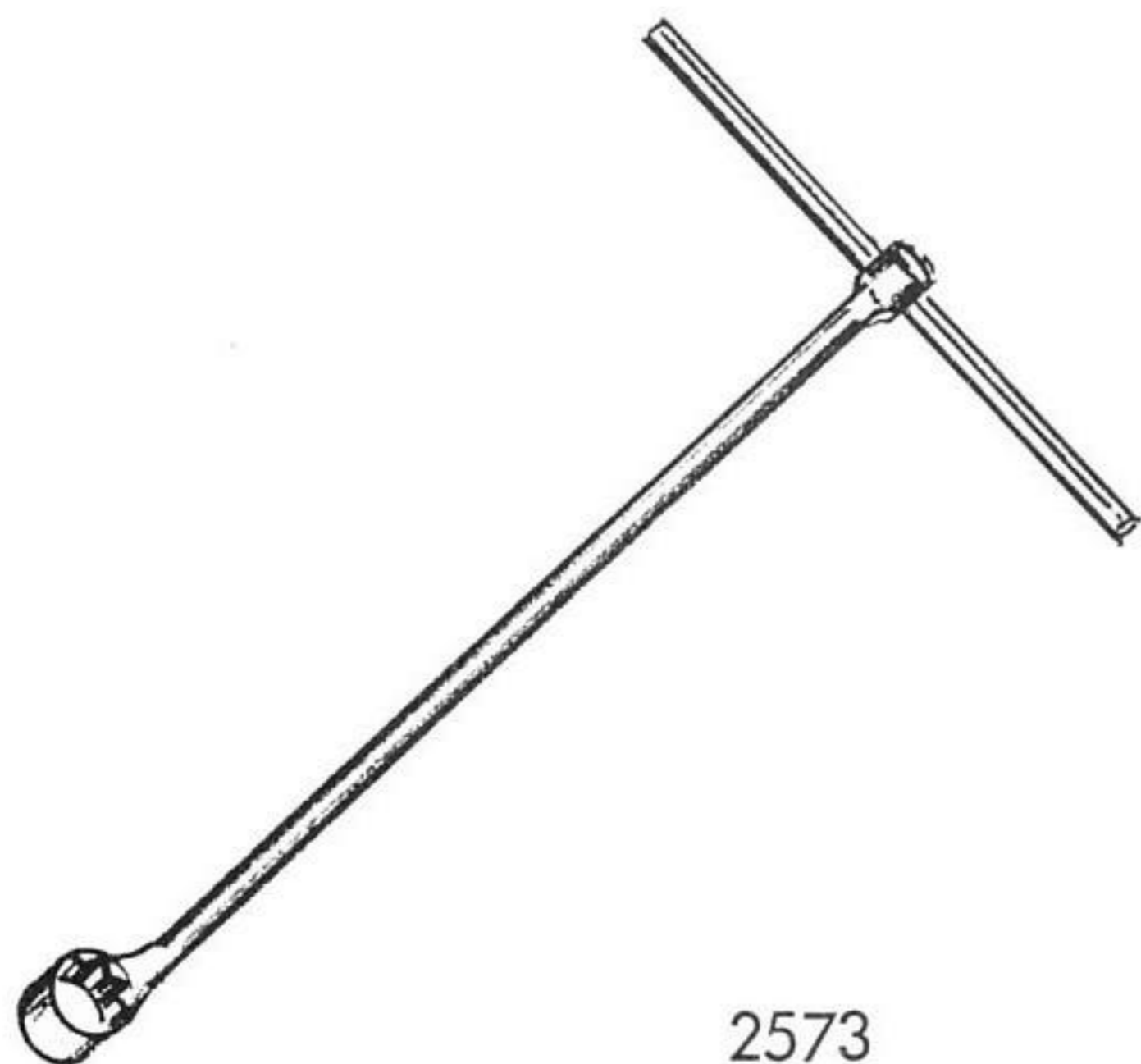

2573



2582

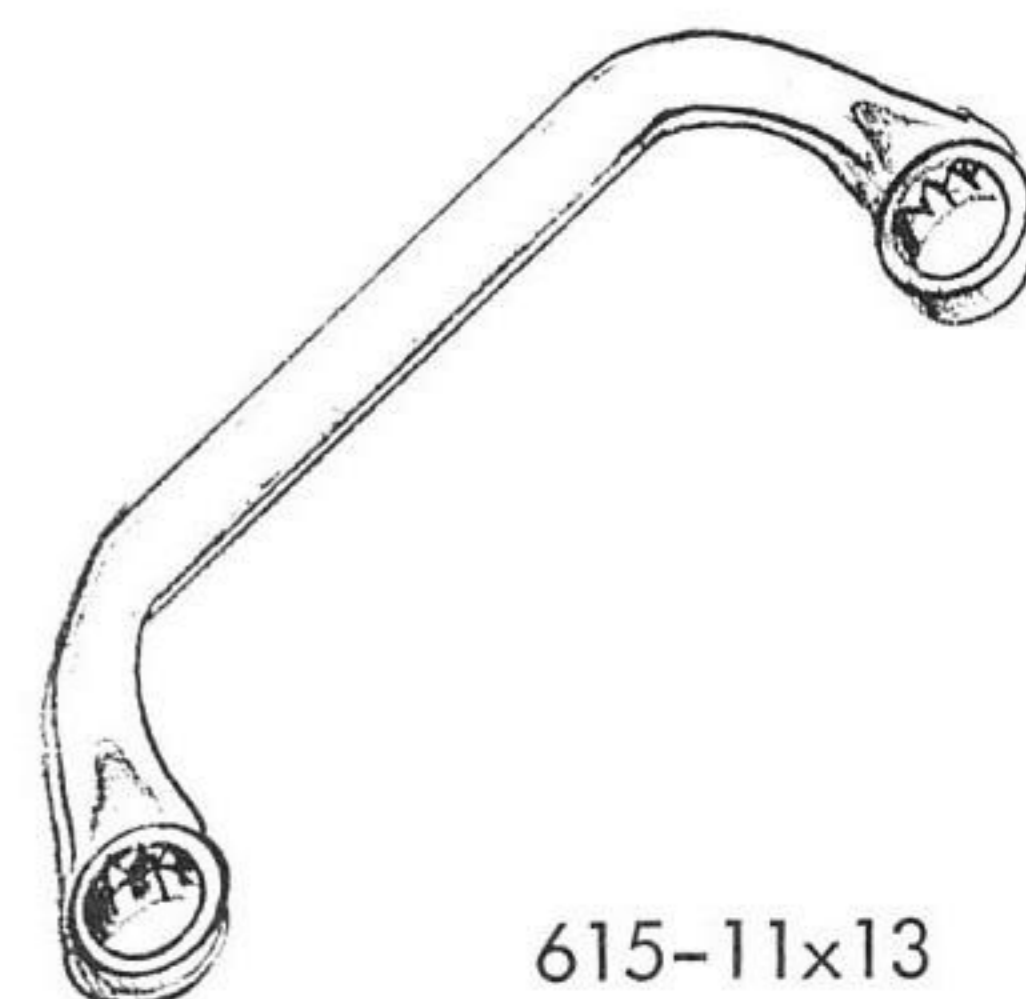

615-11x13

Special TOOLS

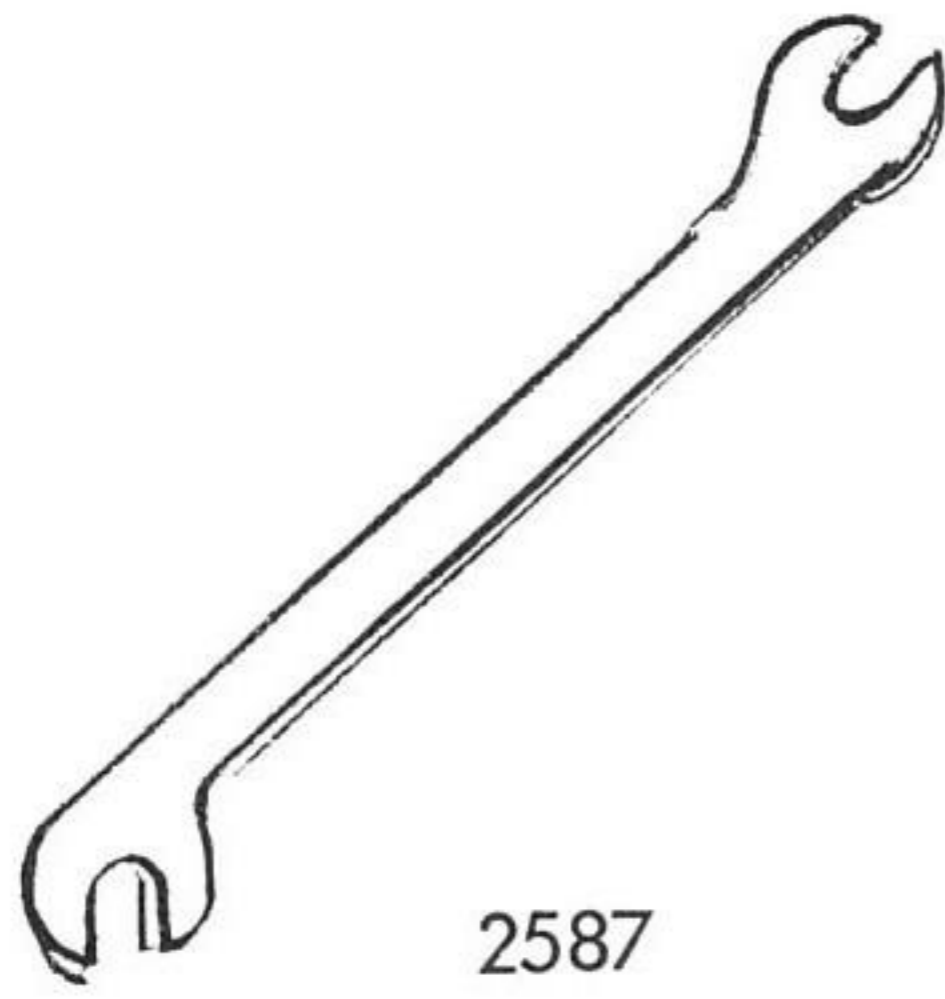

2587

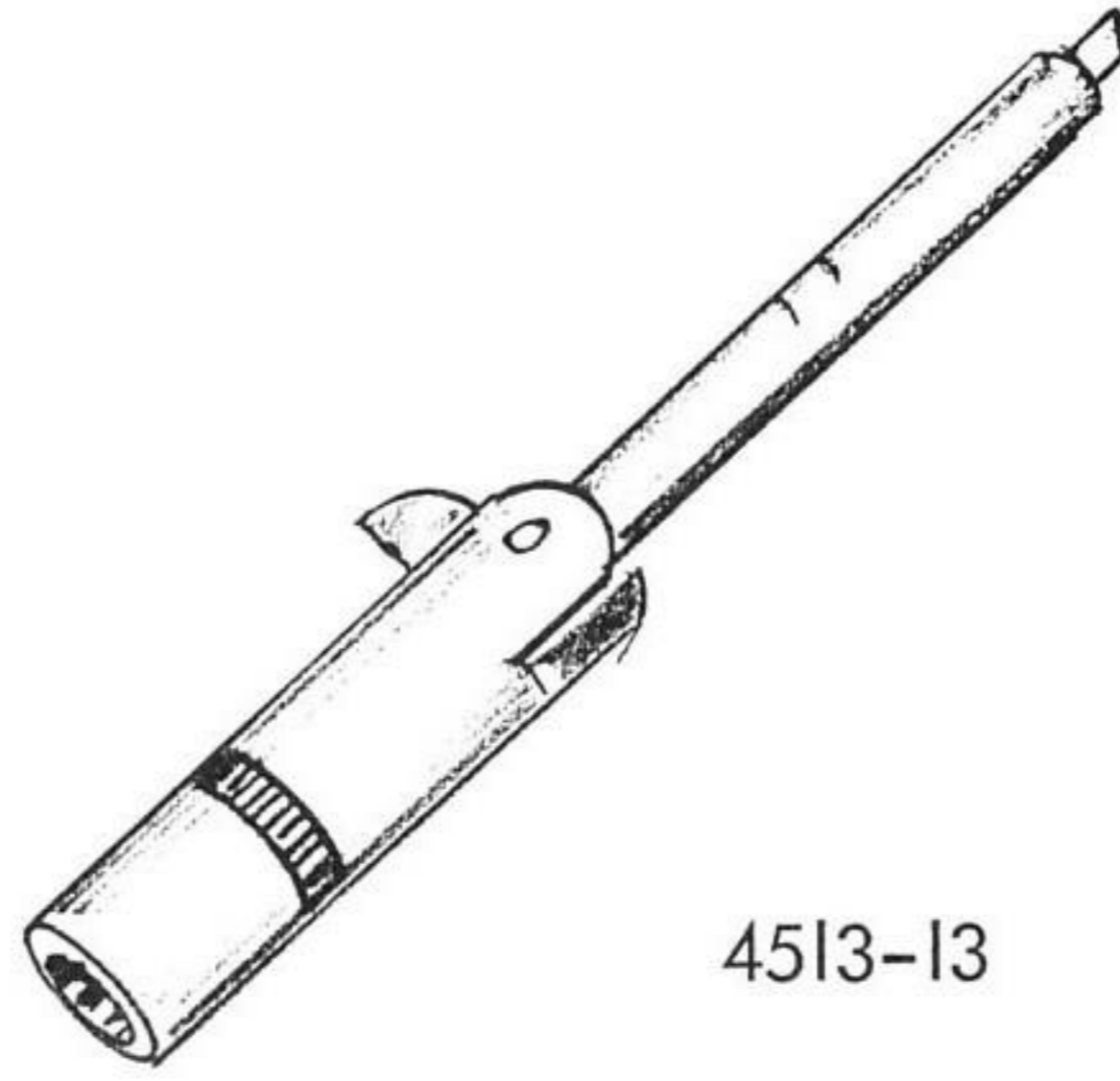

4513-13

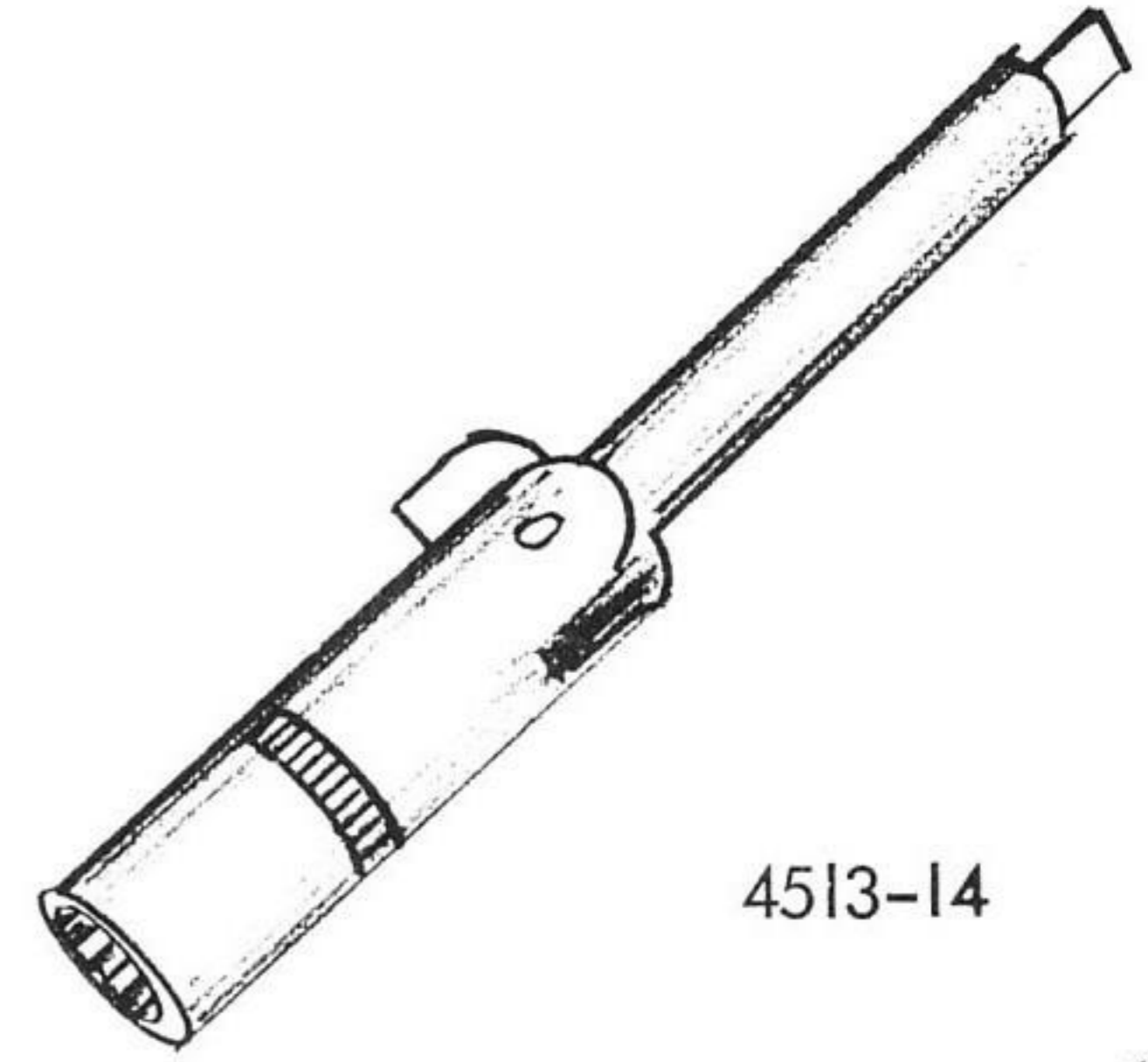

4513-14



650-16



2165-1

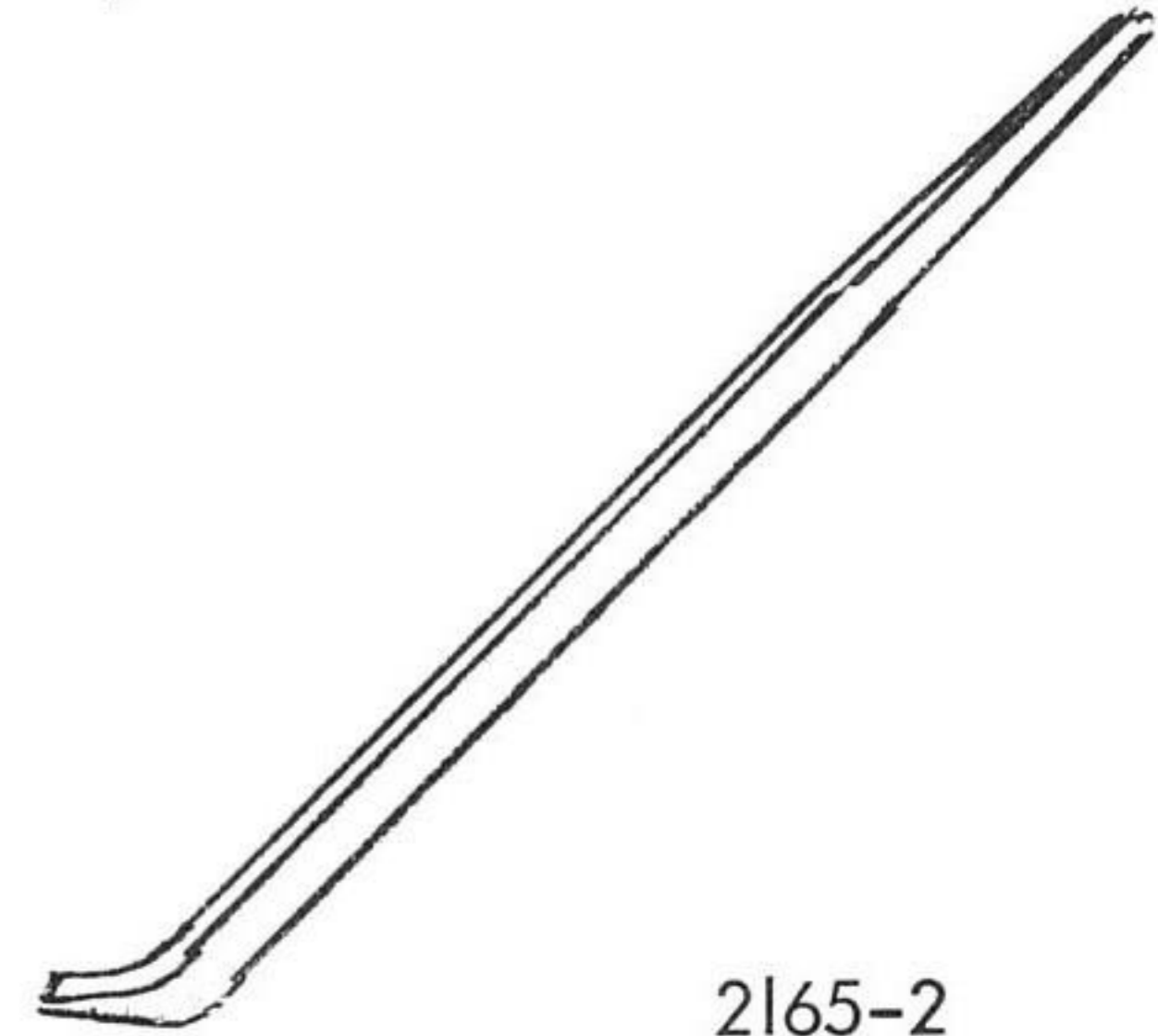

2165-2

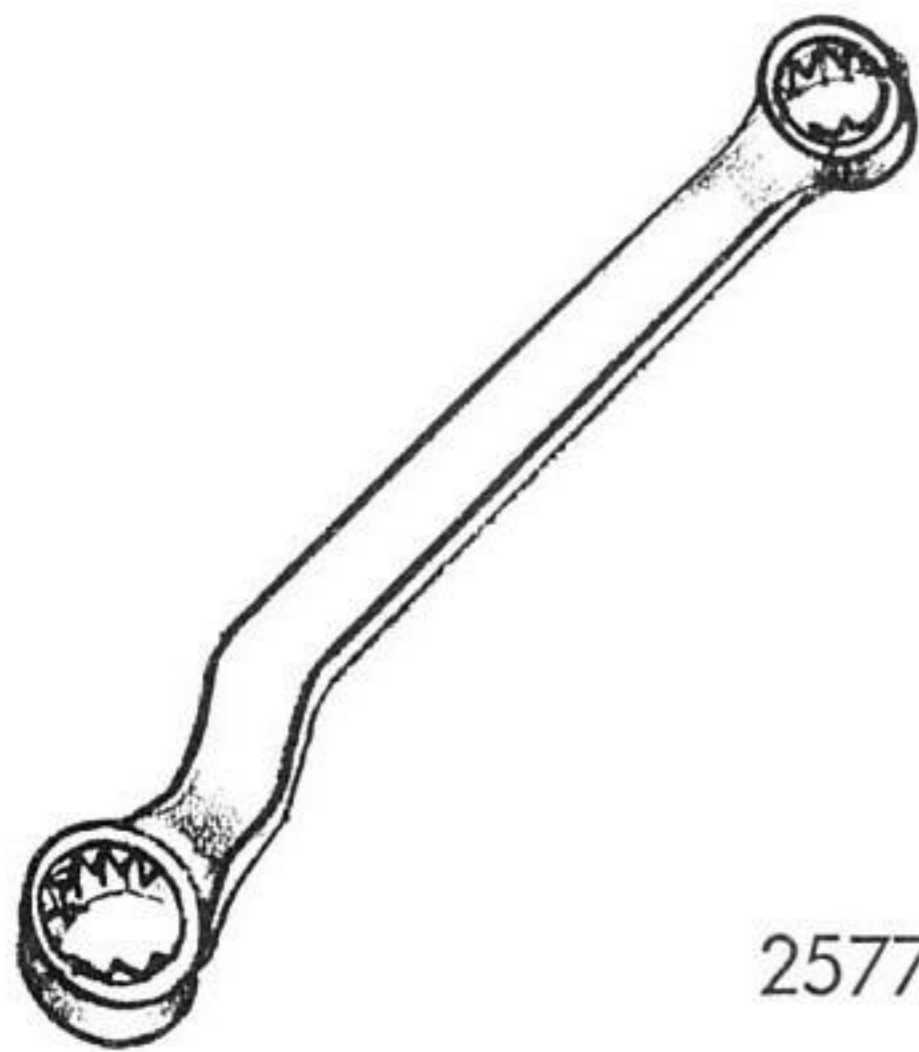

2577

Special TOOLS



US 122 B

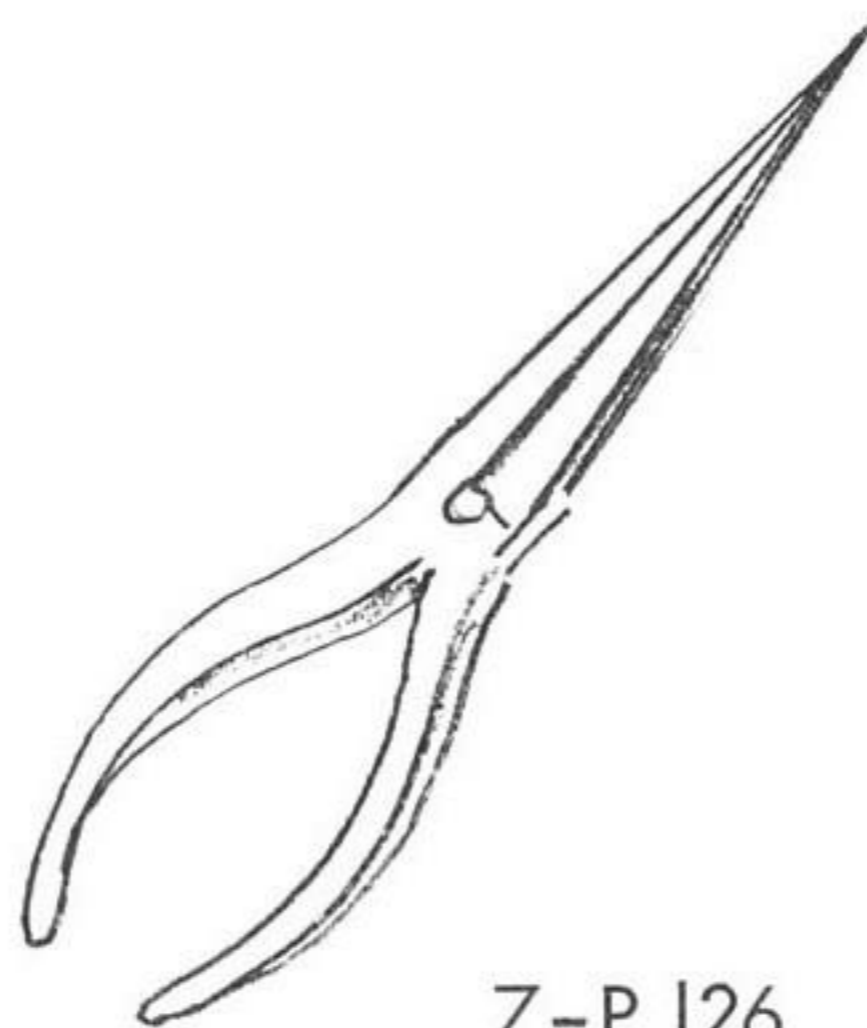

Z-P 126

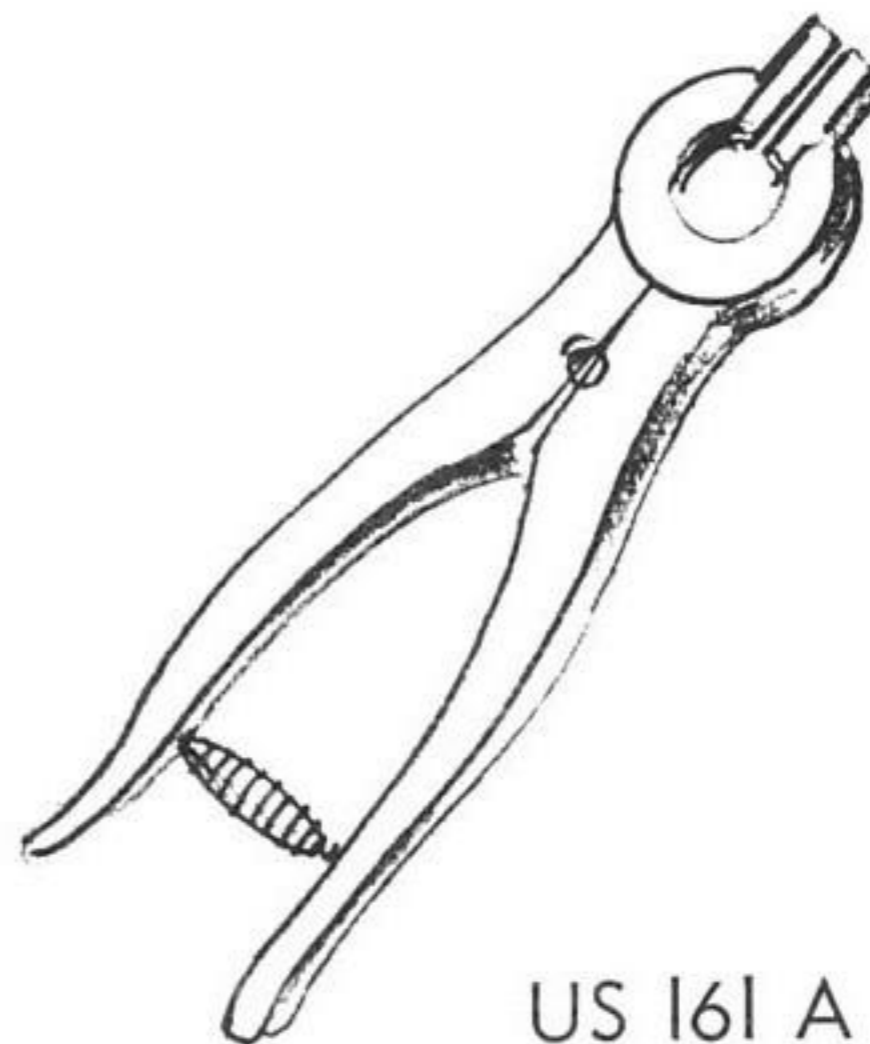

US 161 A

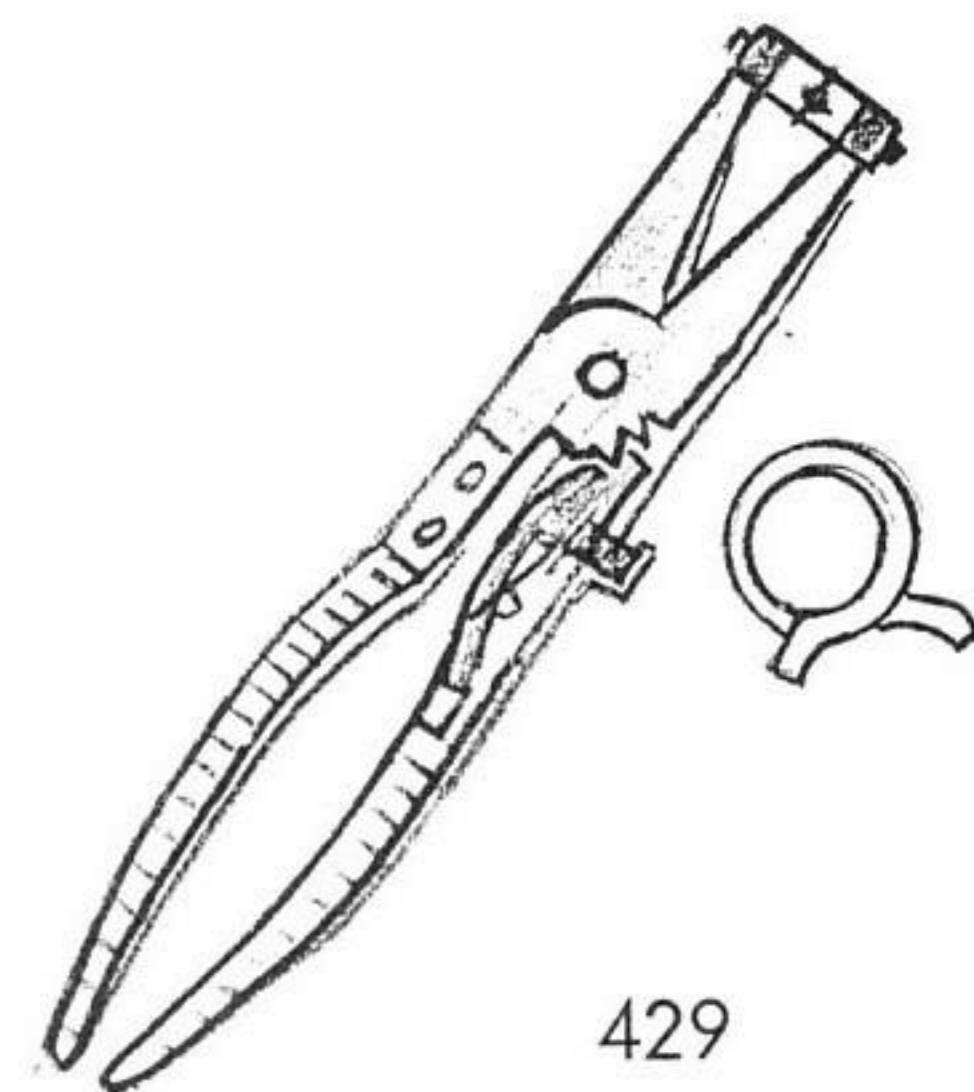

429

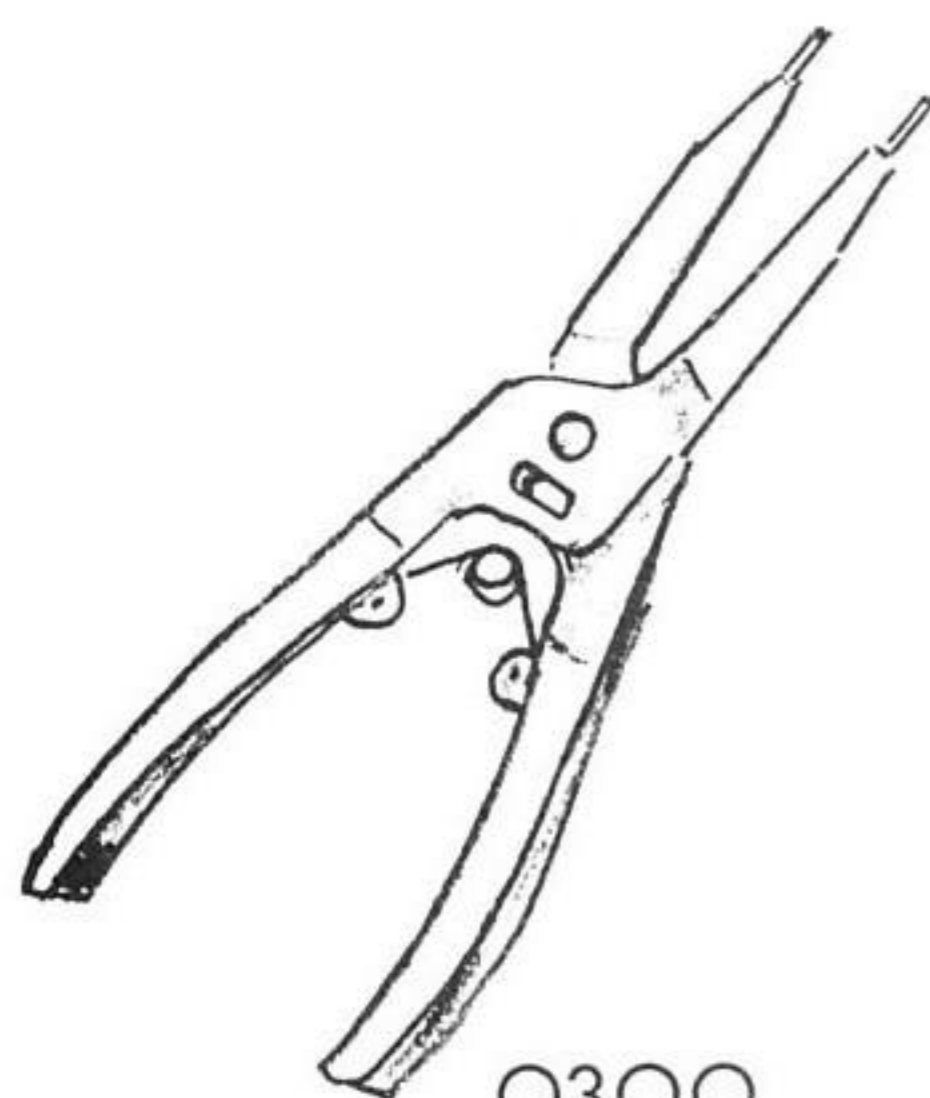

O300

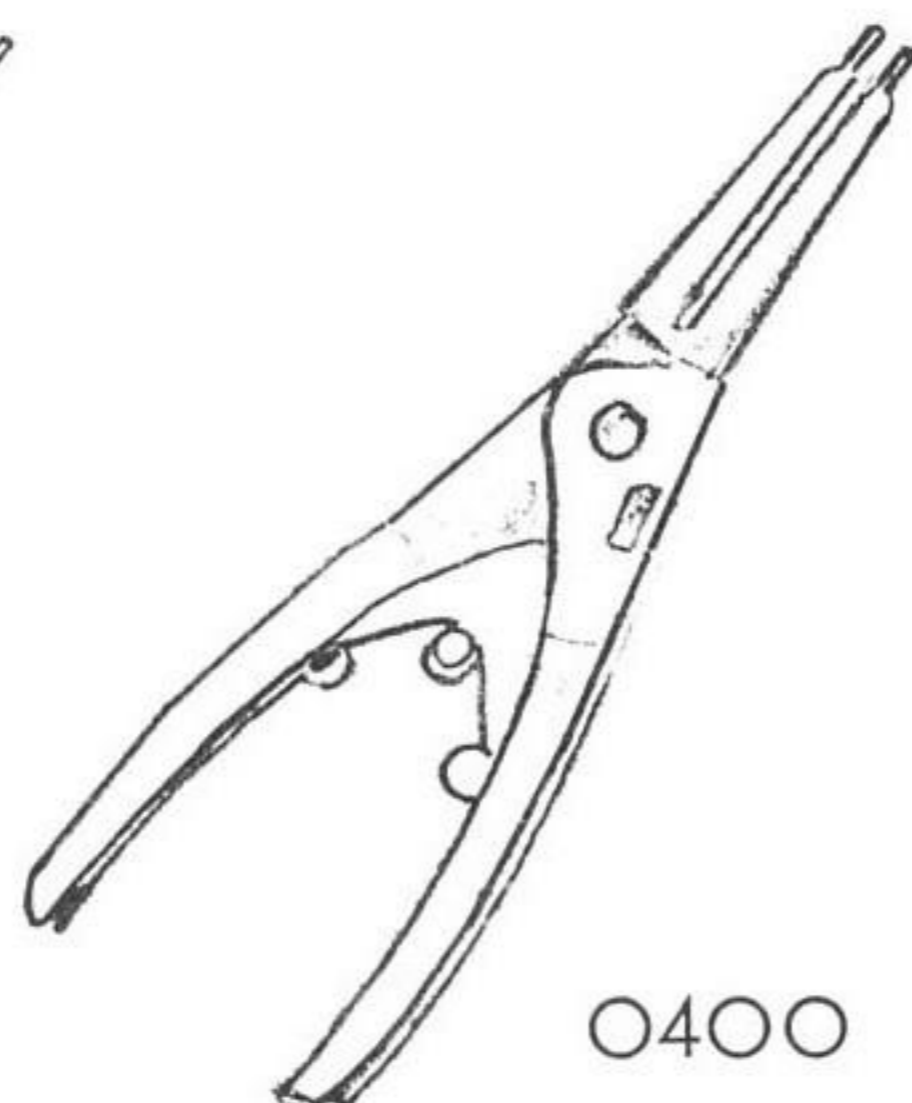

O400

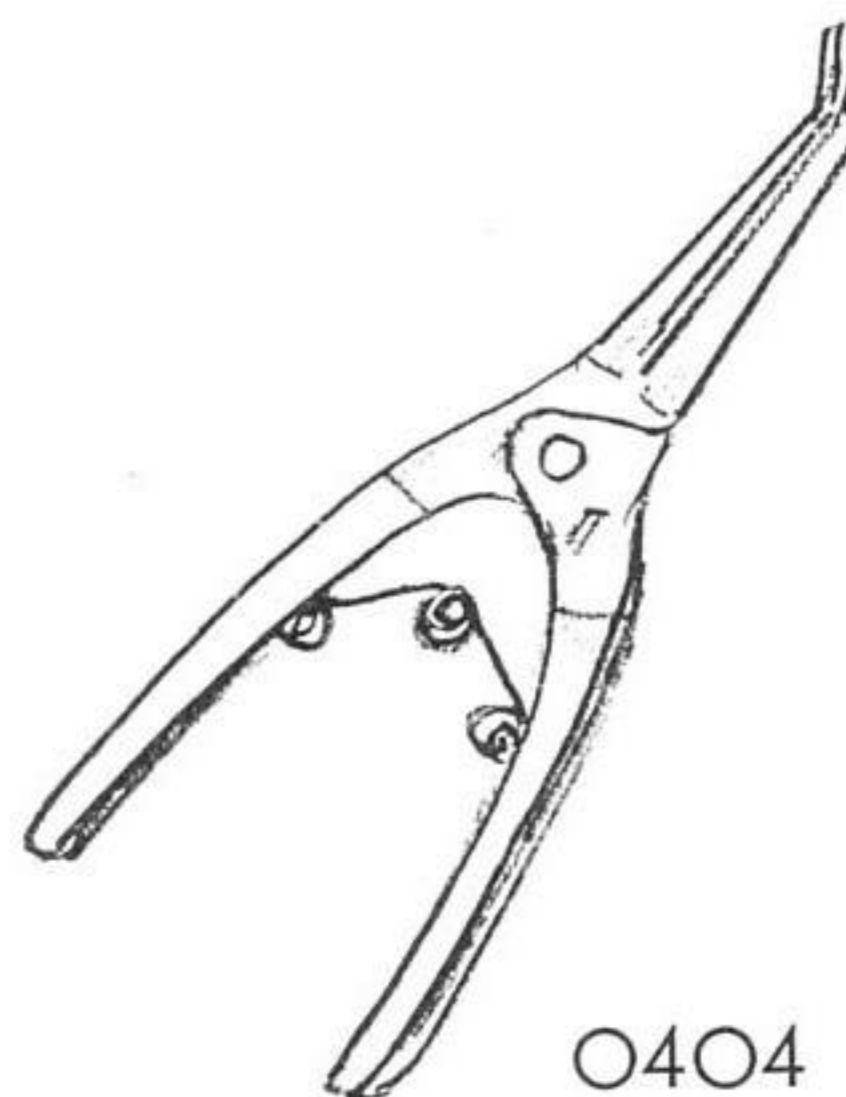

O404

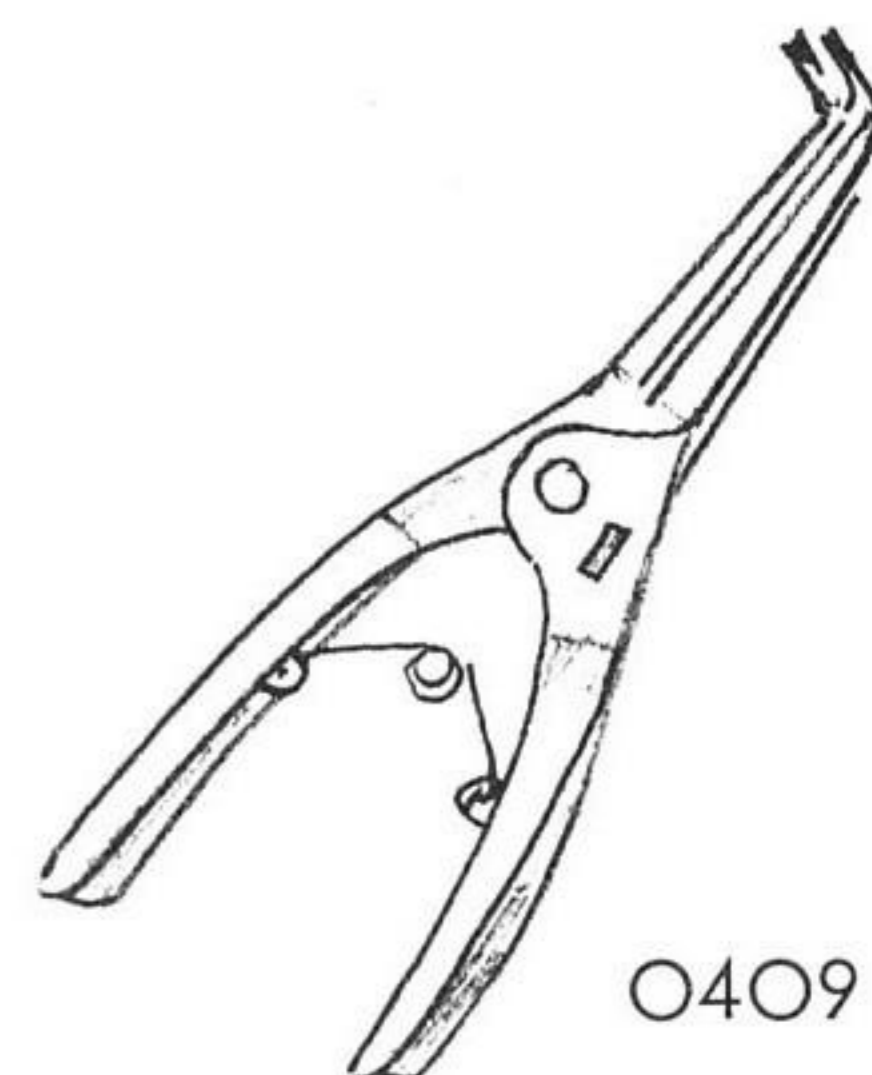

O409

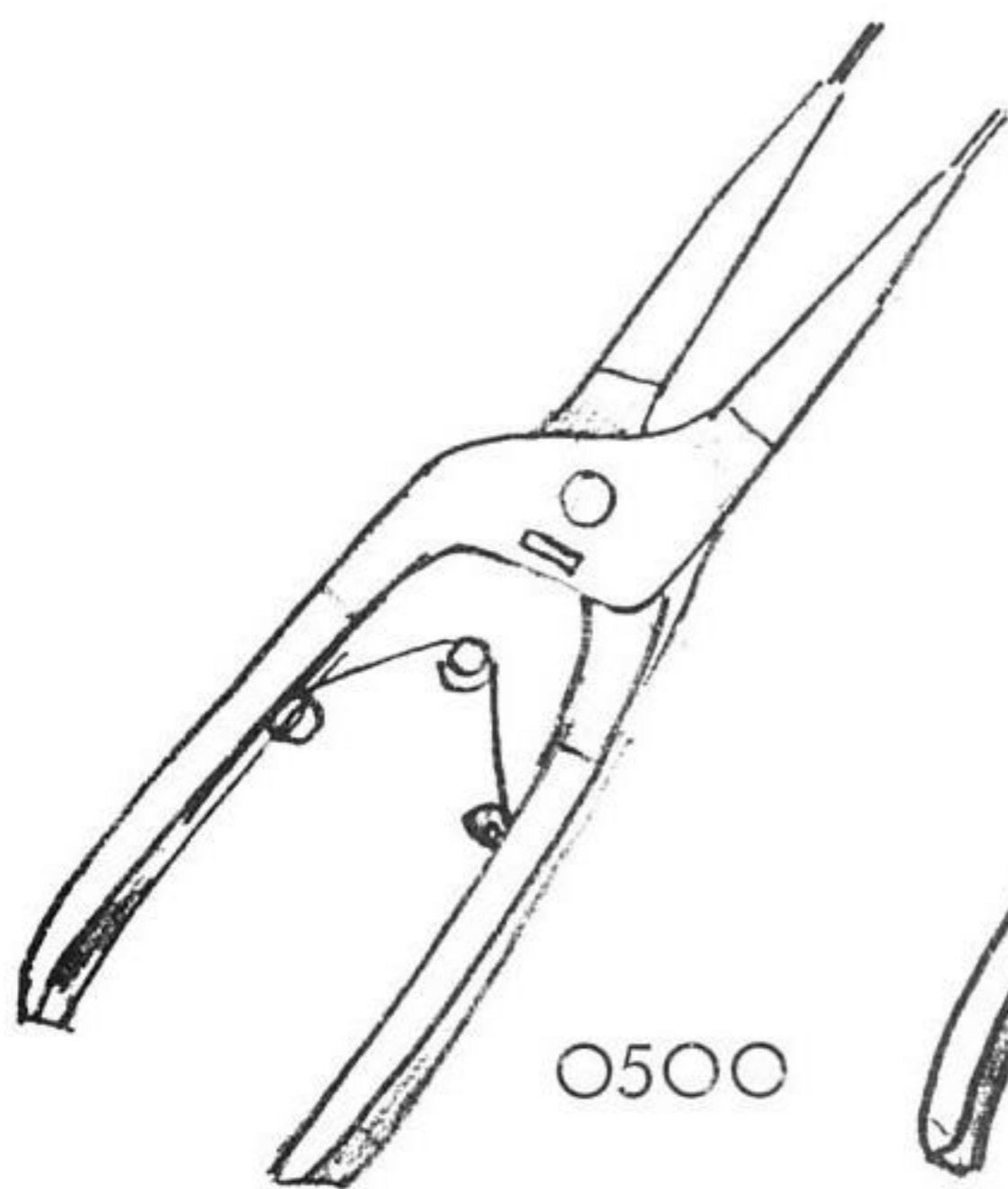

O500

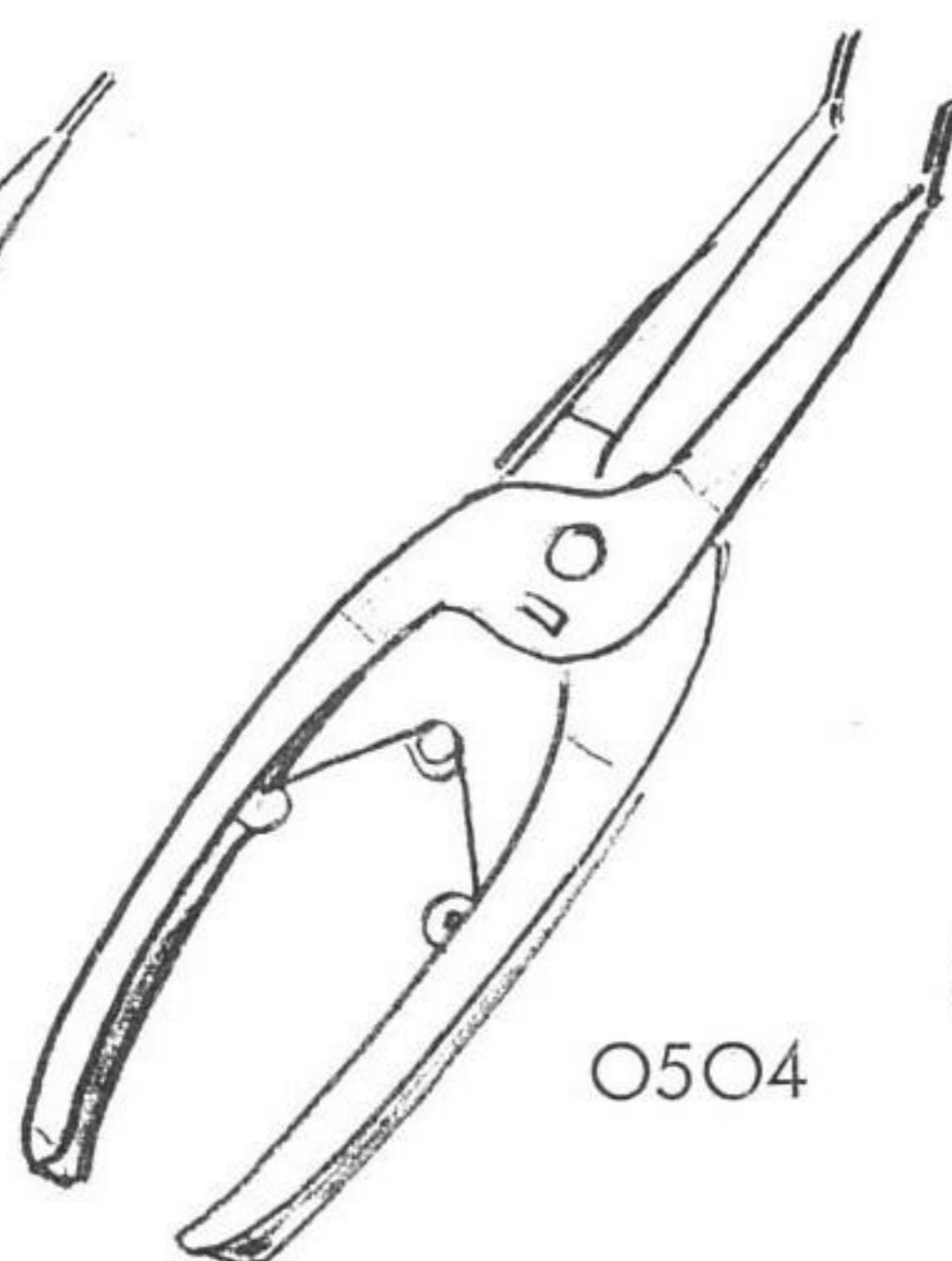

O504

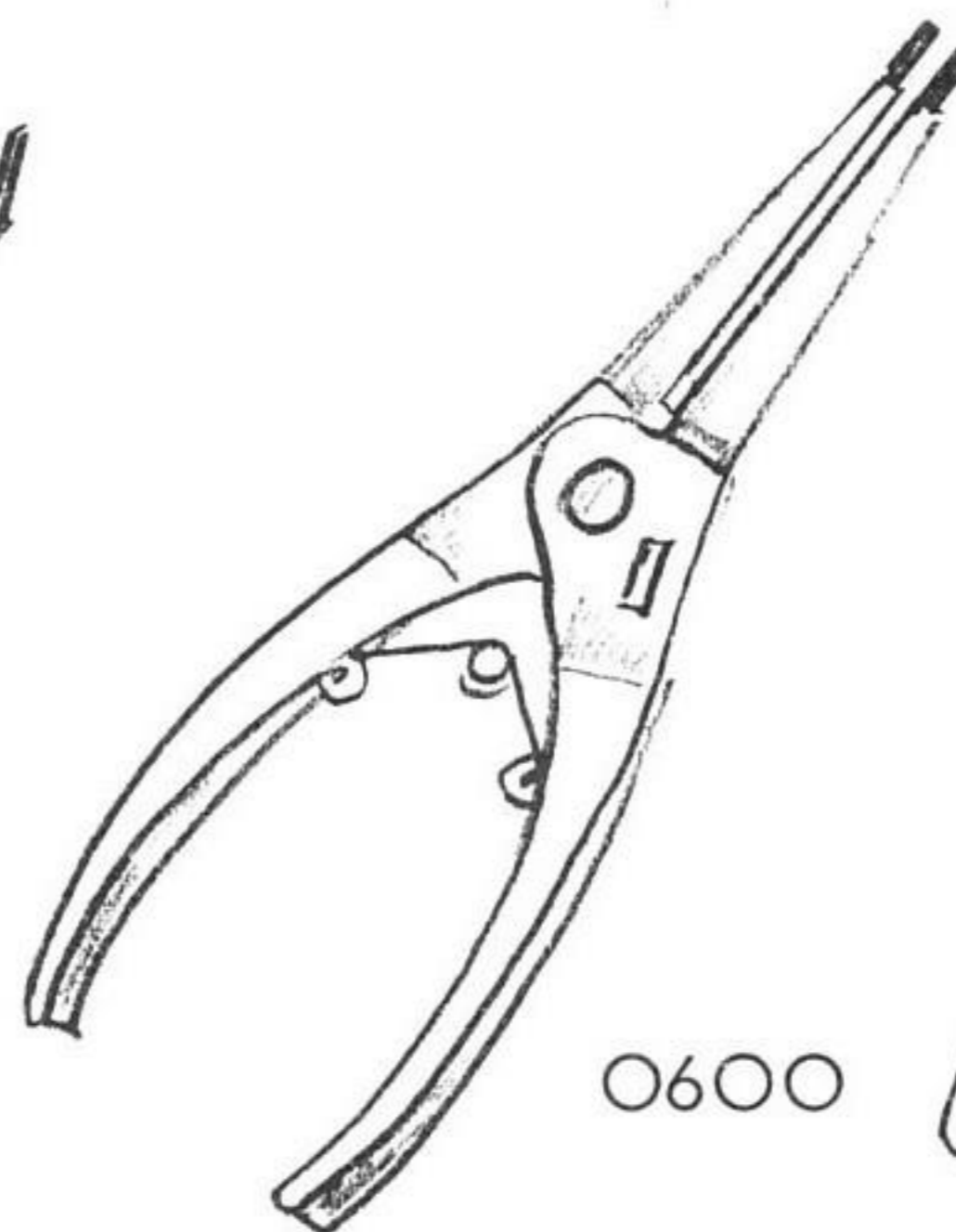

O600

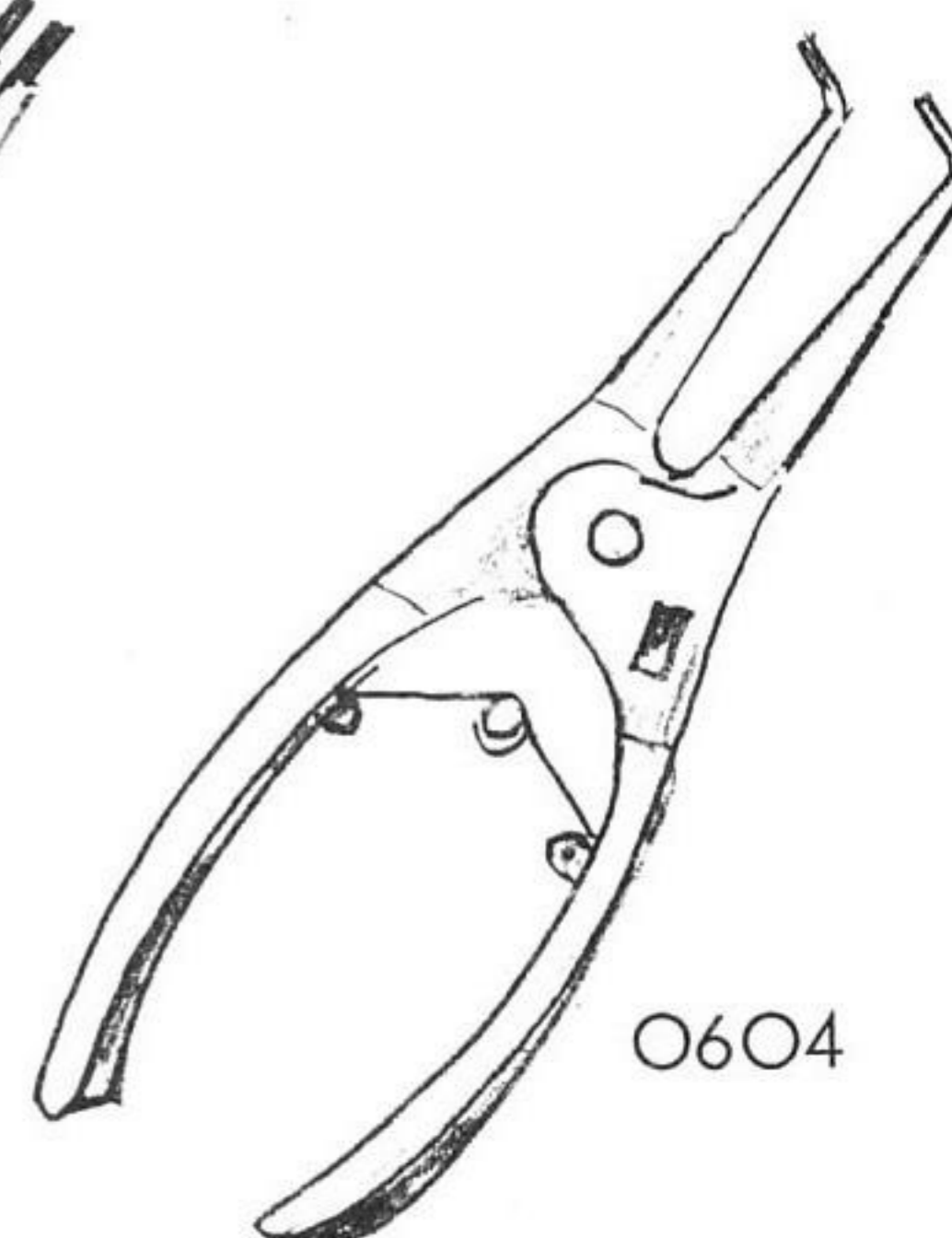

O604



Z-P 316

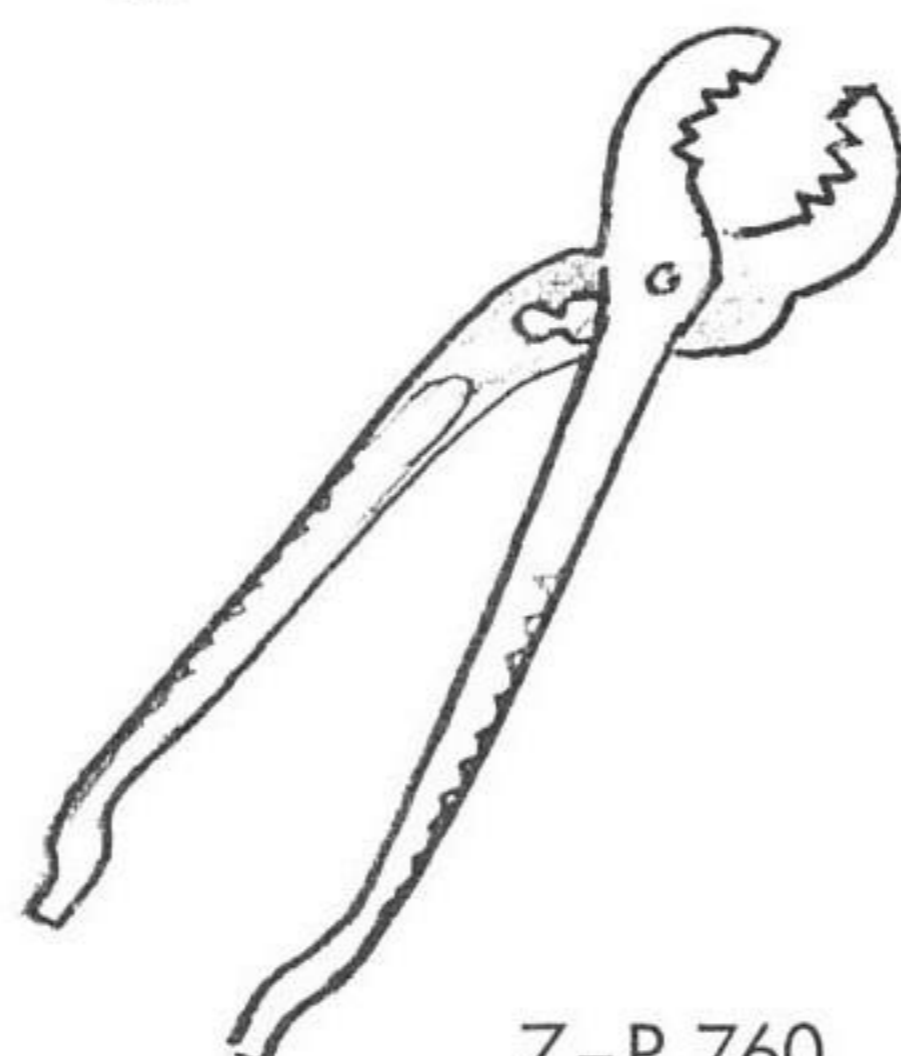

Z-P 760

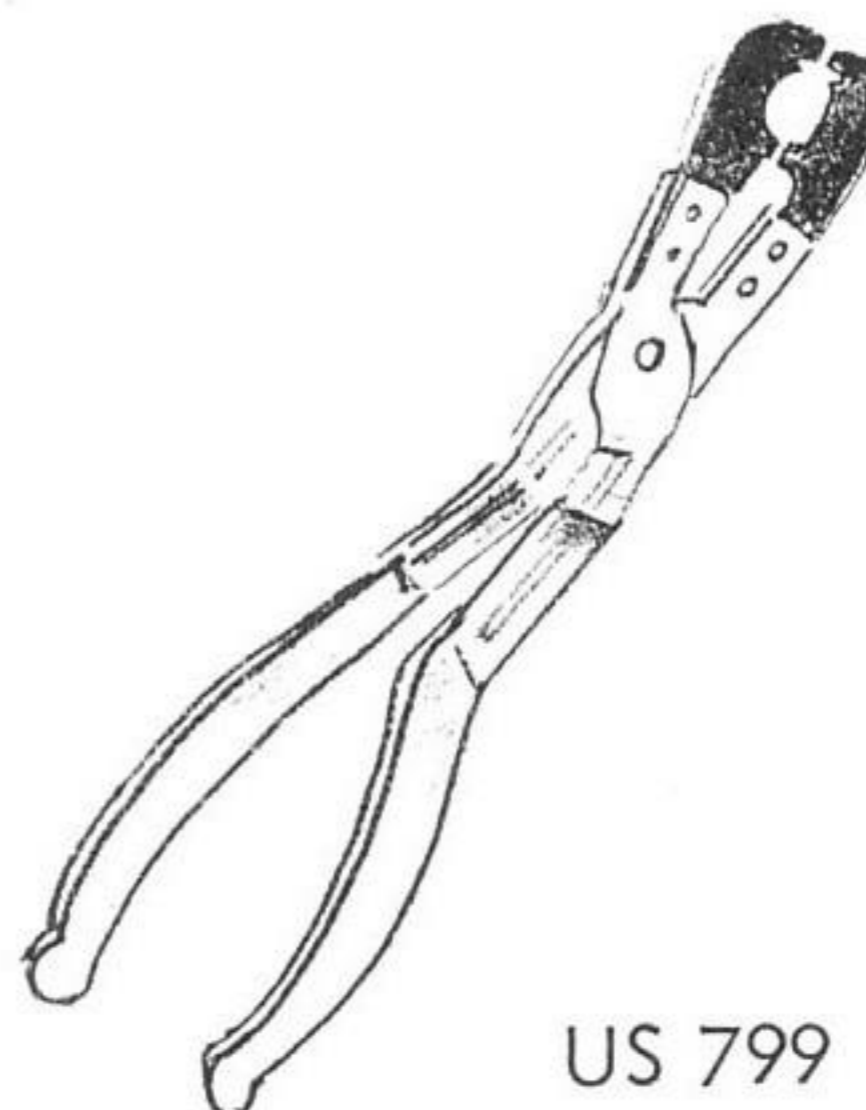

US 799



1515



Special TOOLS

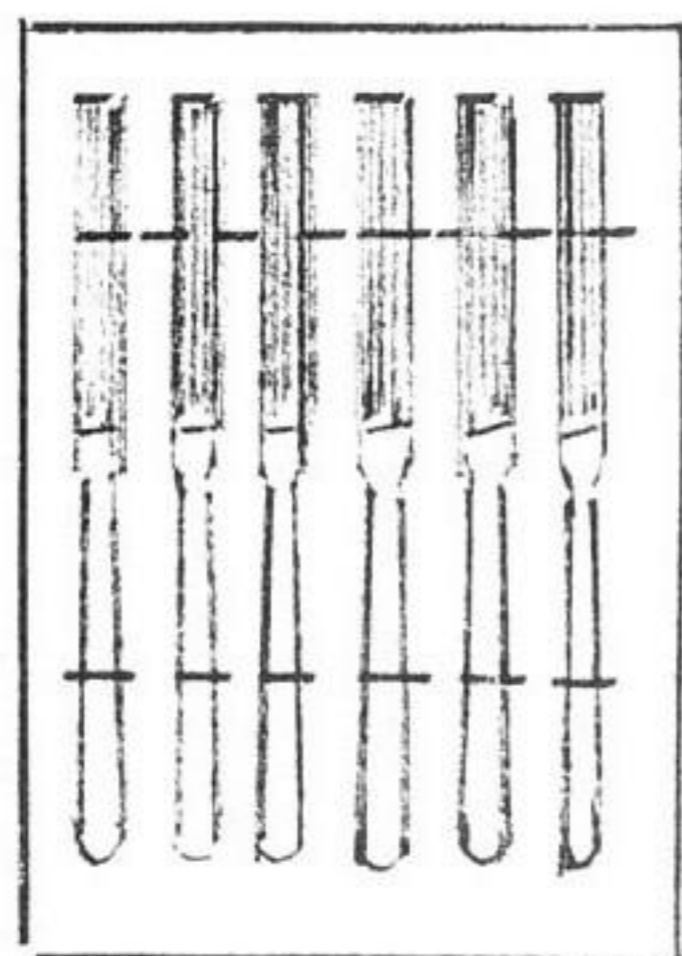

ZF-8729-6

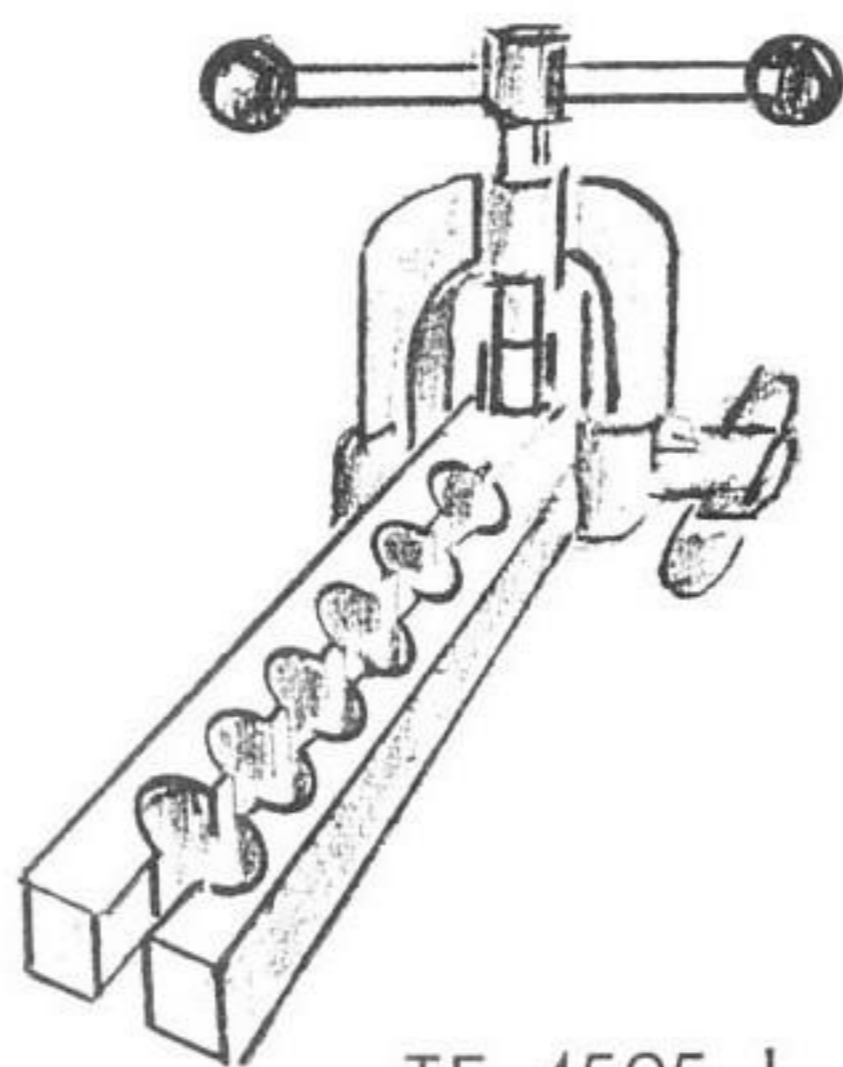

TF-4595-1

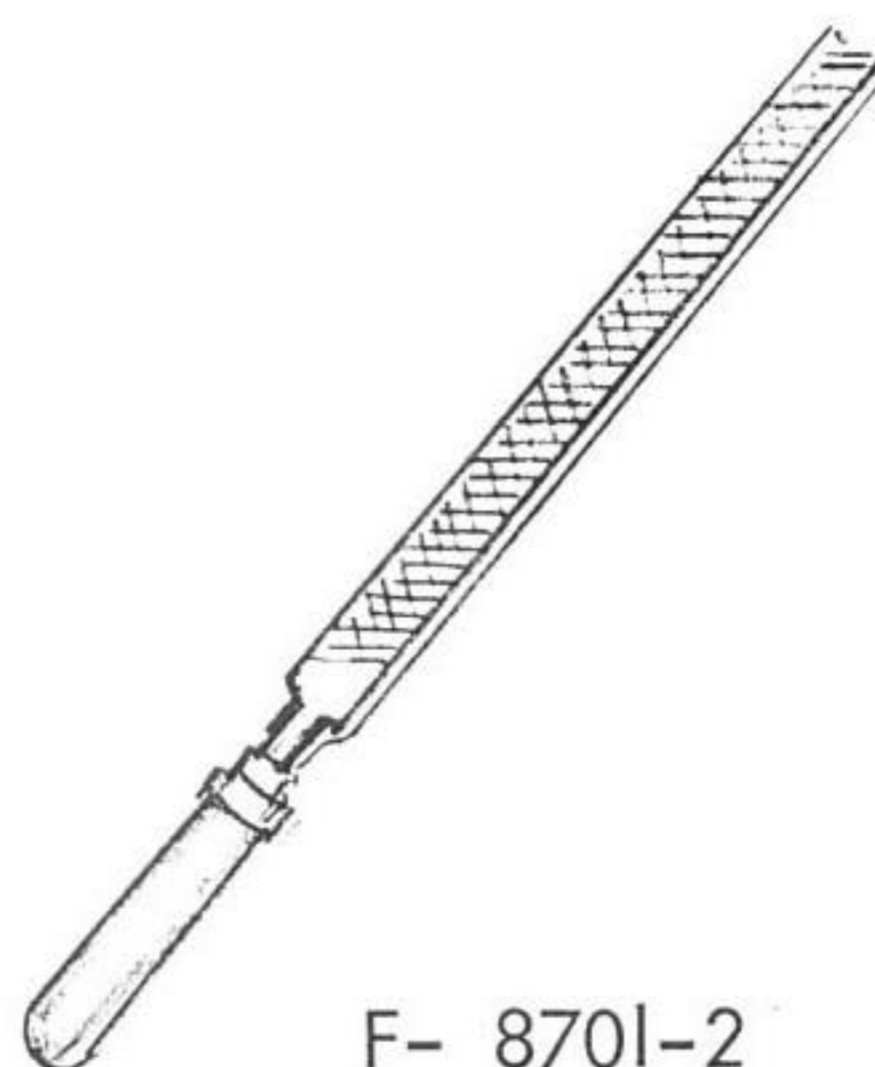

F- 8701-2



F-8719 - 2

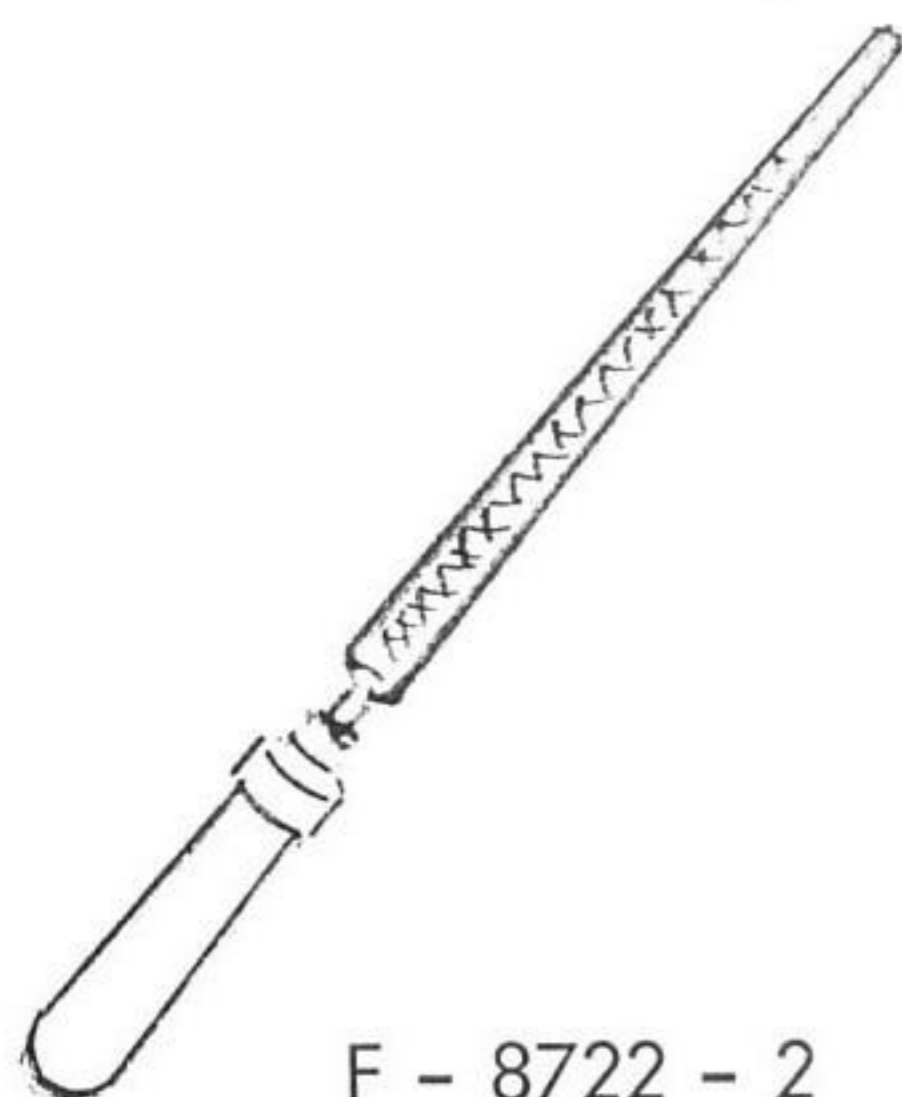

F - 8722 - 2

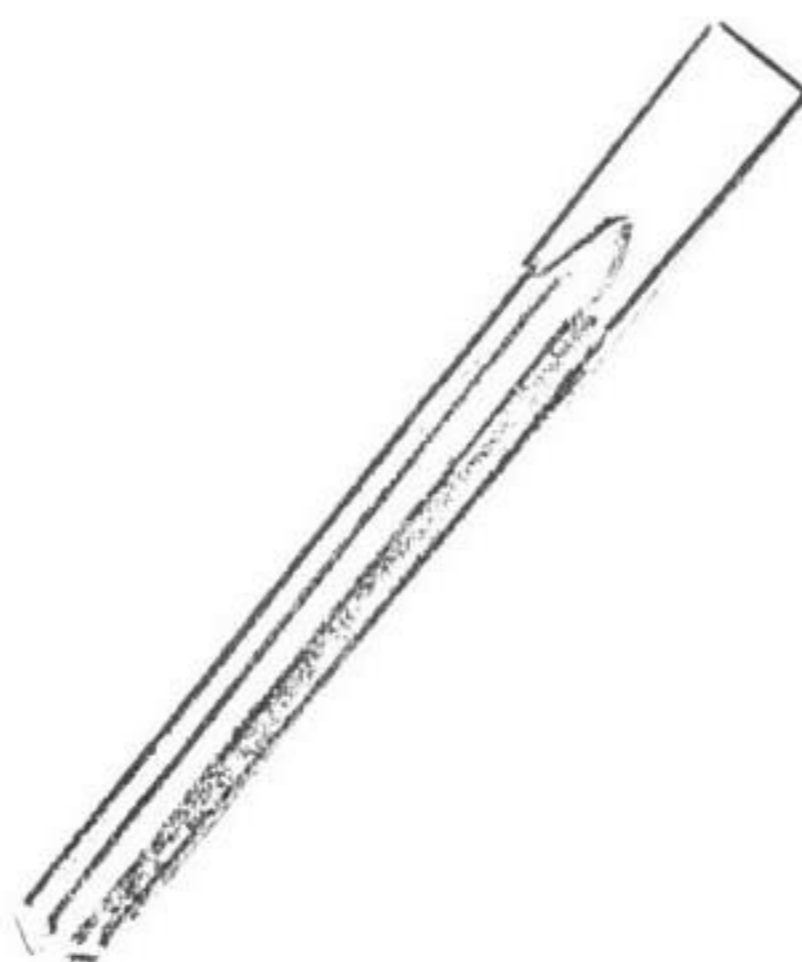

C 352 - 112

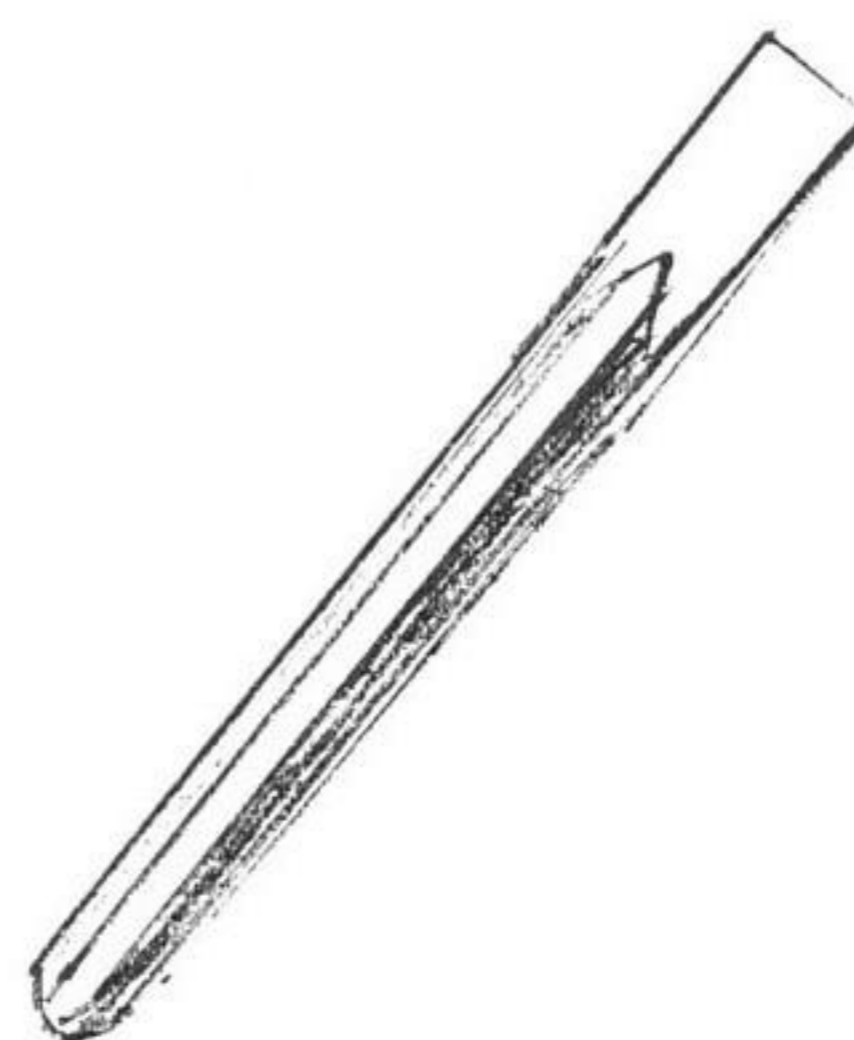

C 352 - 116

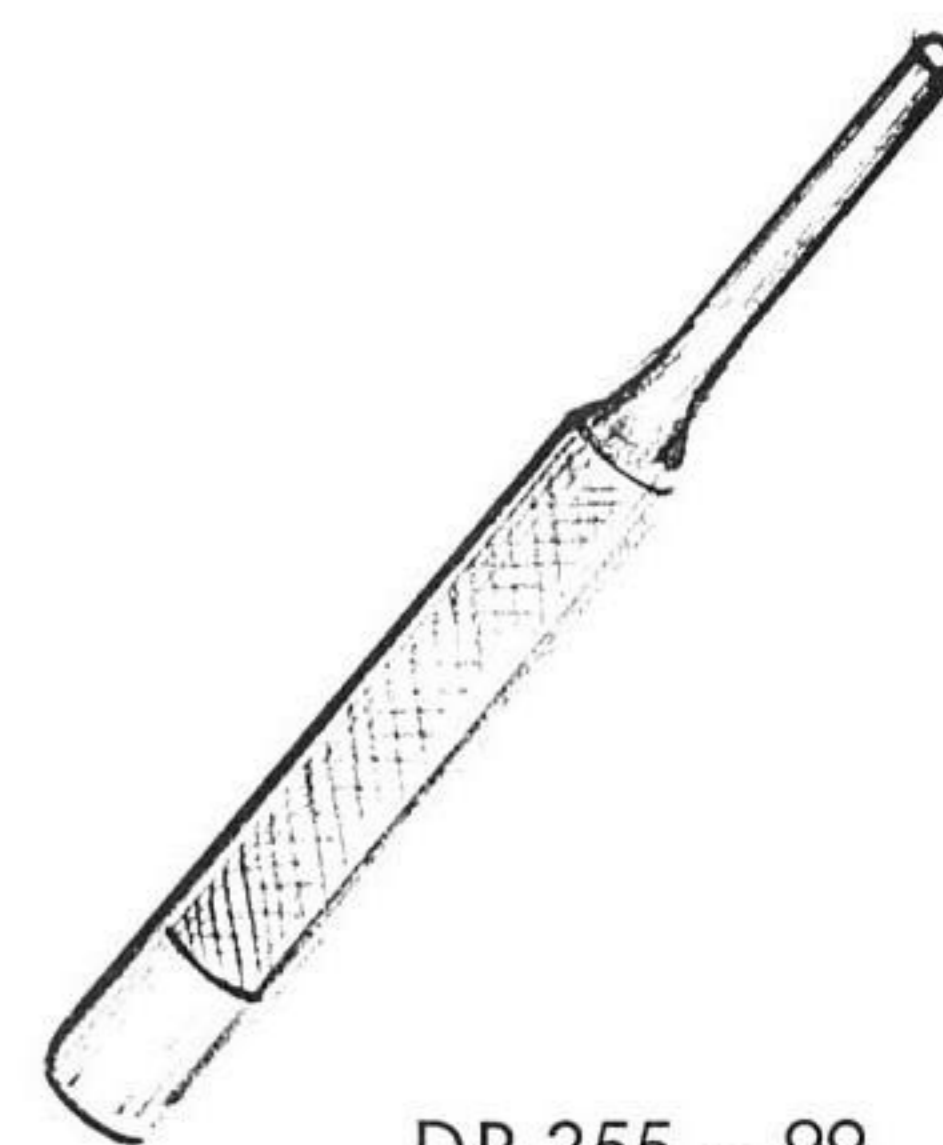

DP 355 - 99



DP 355 - 103



CP 350 - 101



O 102



O 100

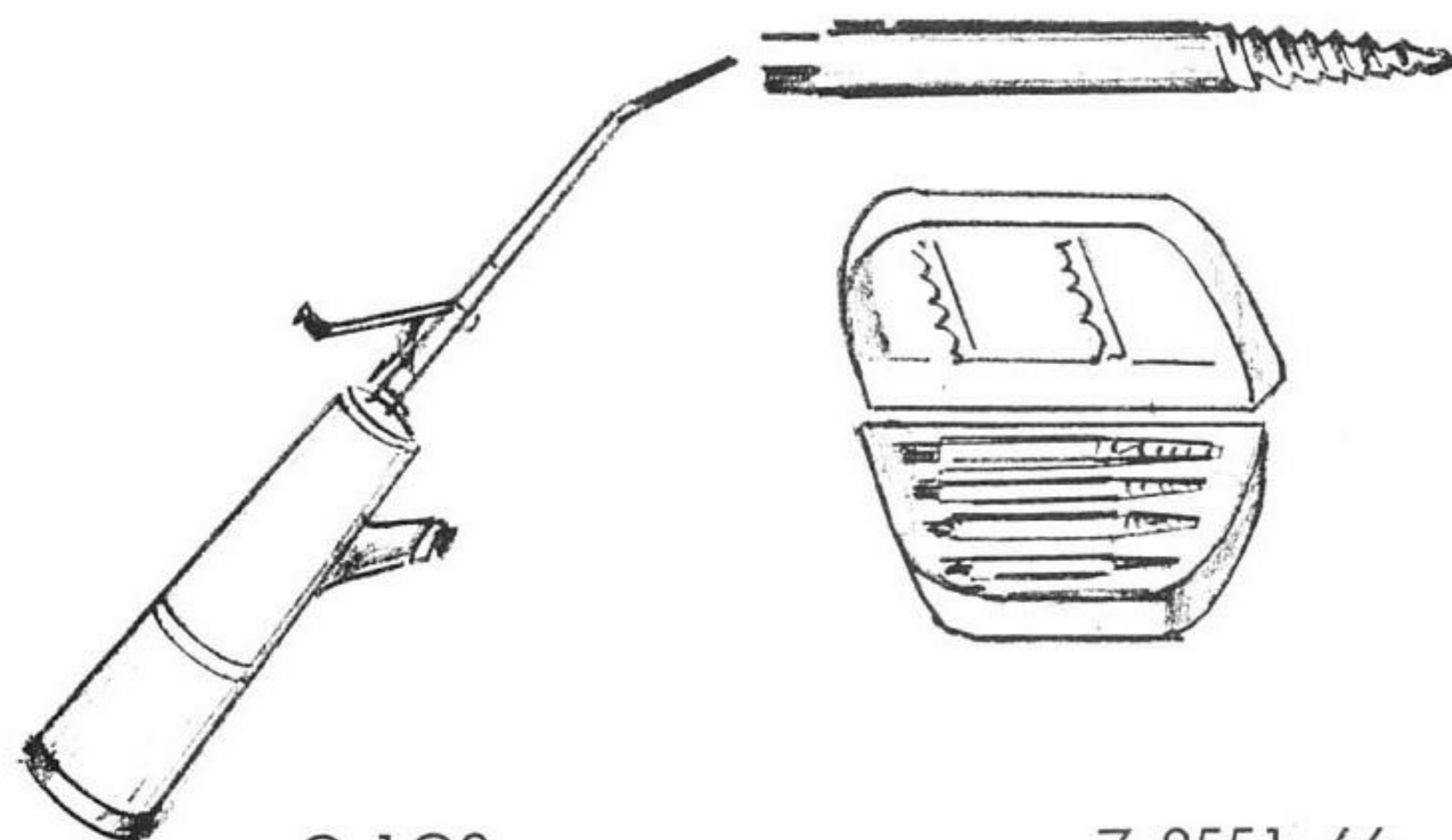

O 103

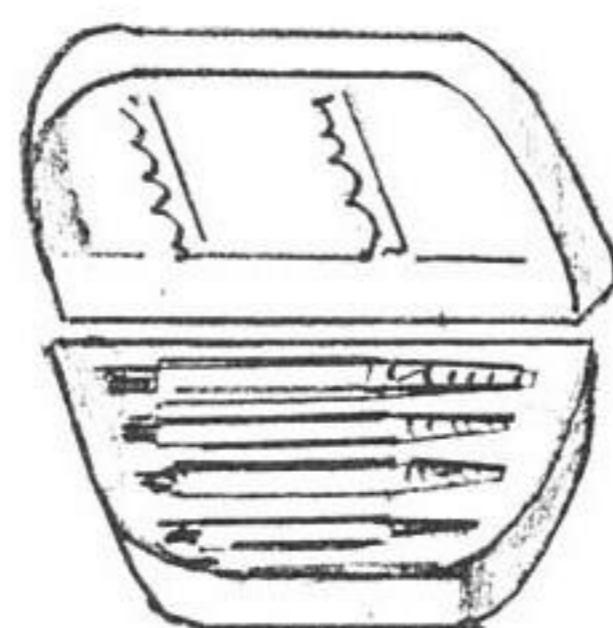

Z 8551-66



R.A.P.A.



Special TOOLS

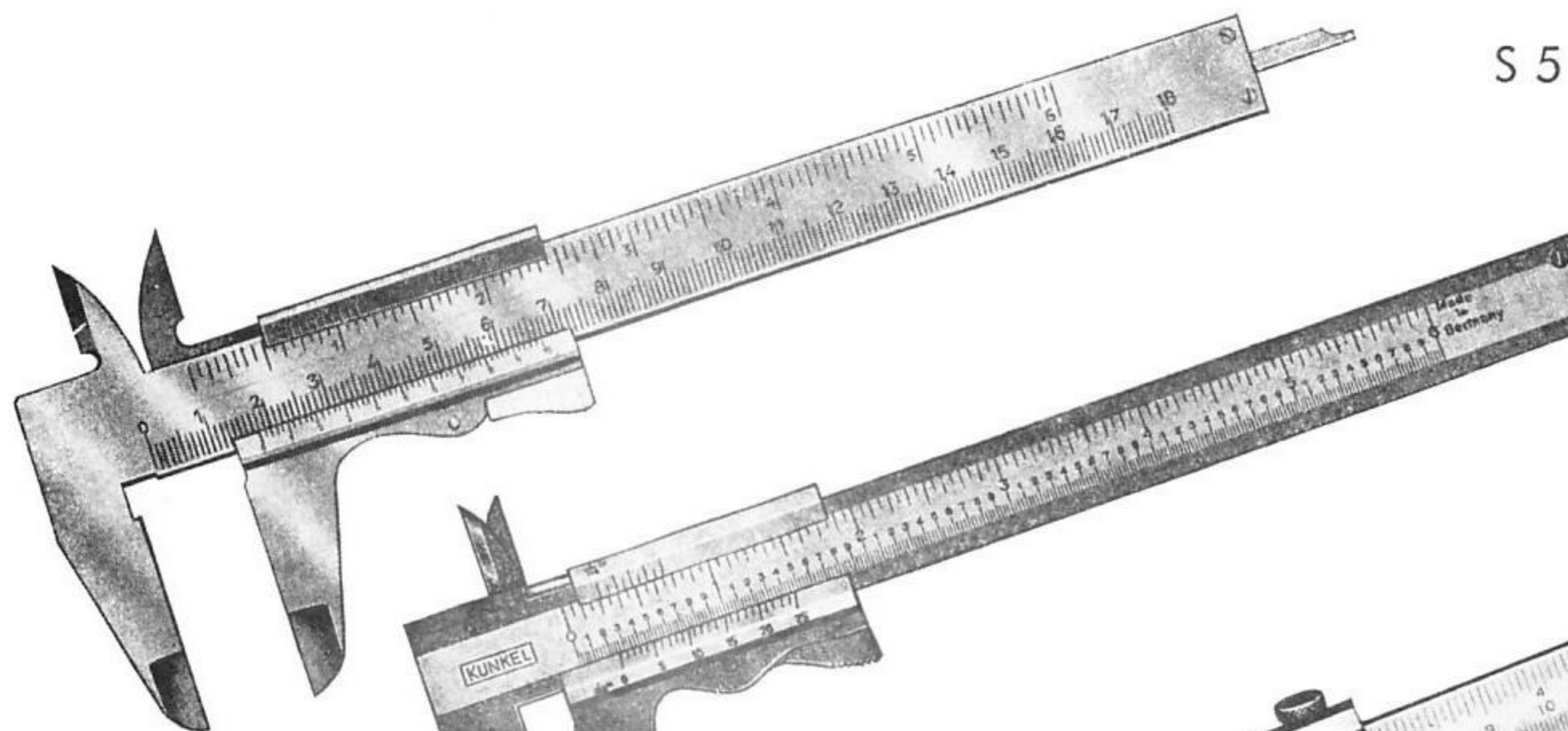

S 5

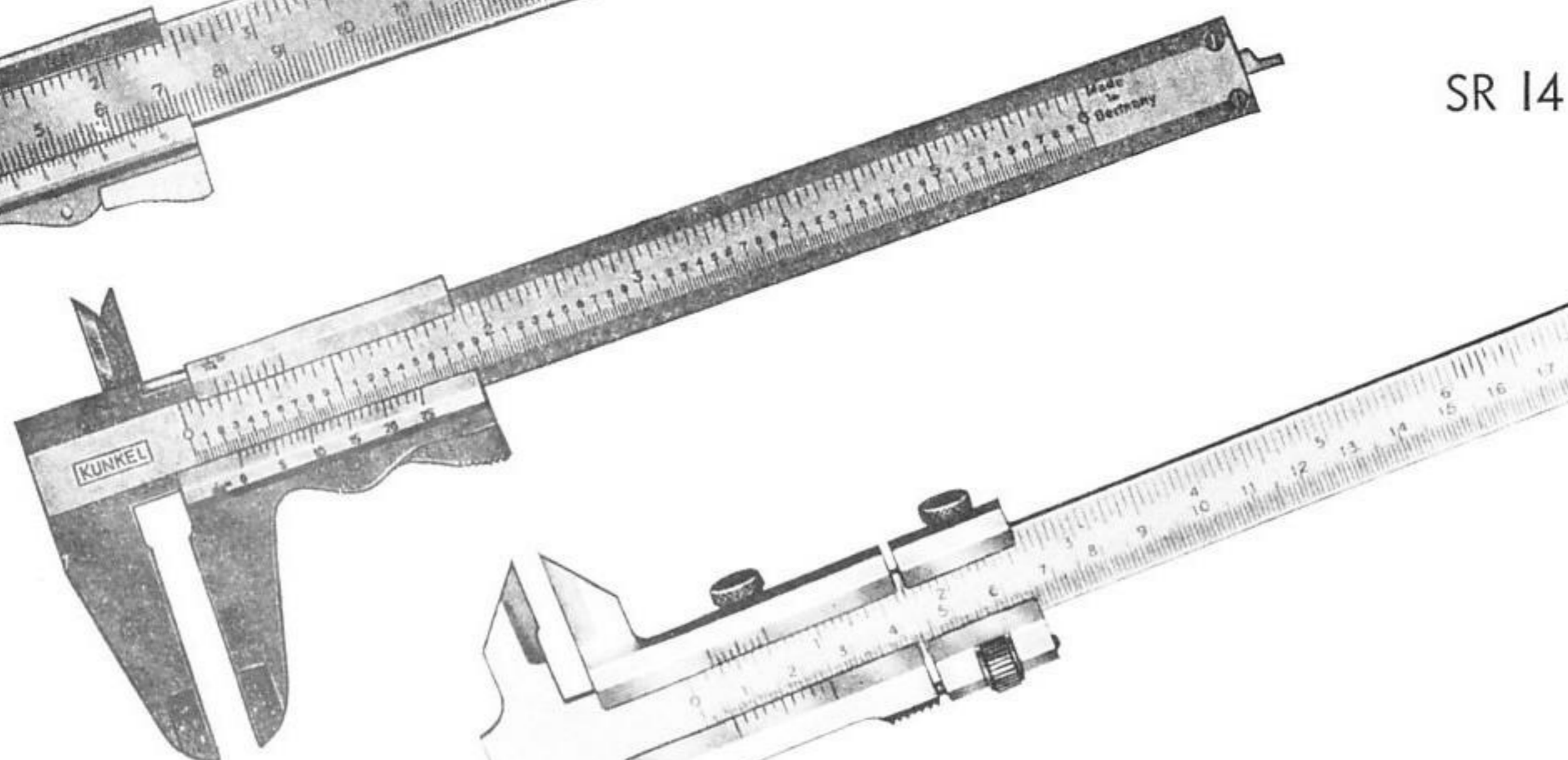

SR 14

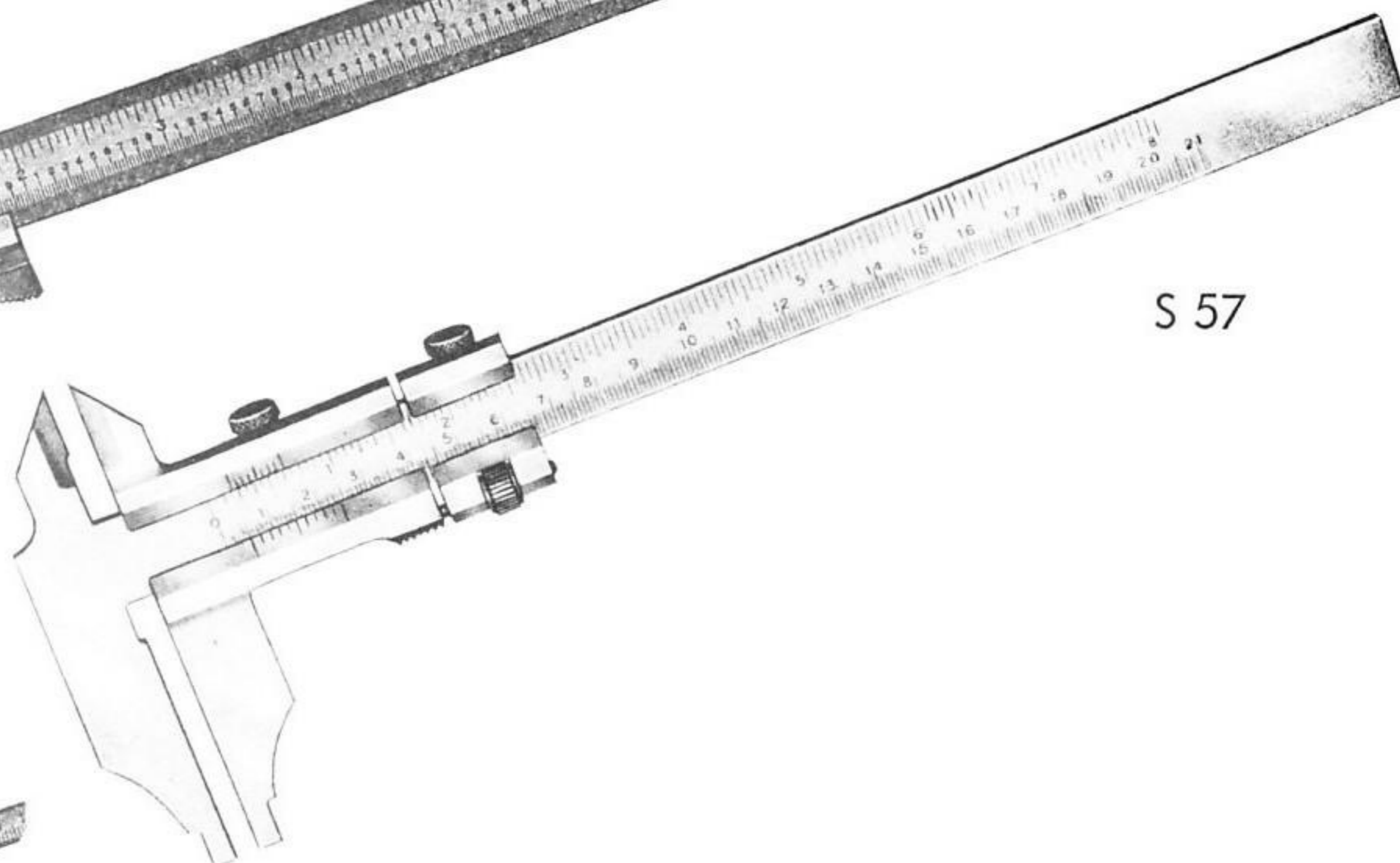

S 57

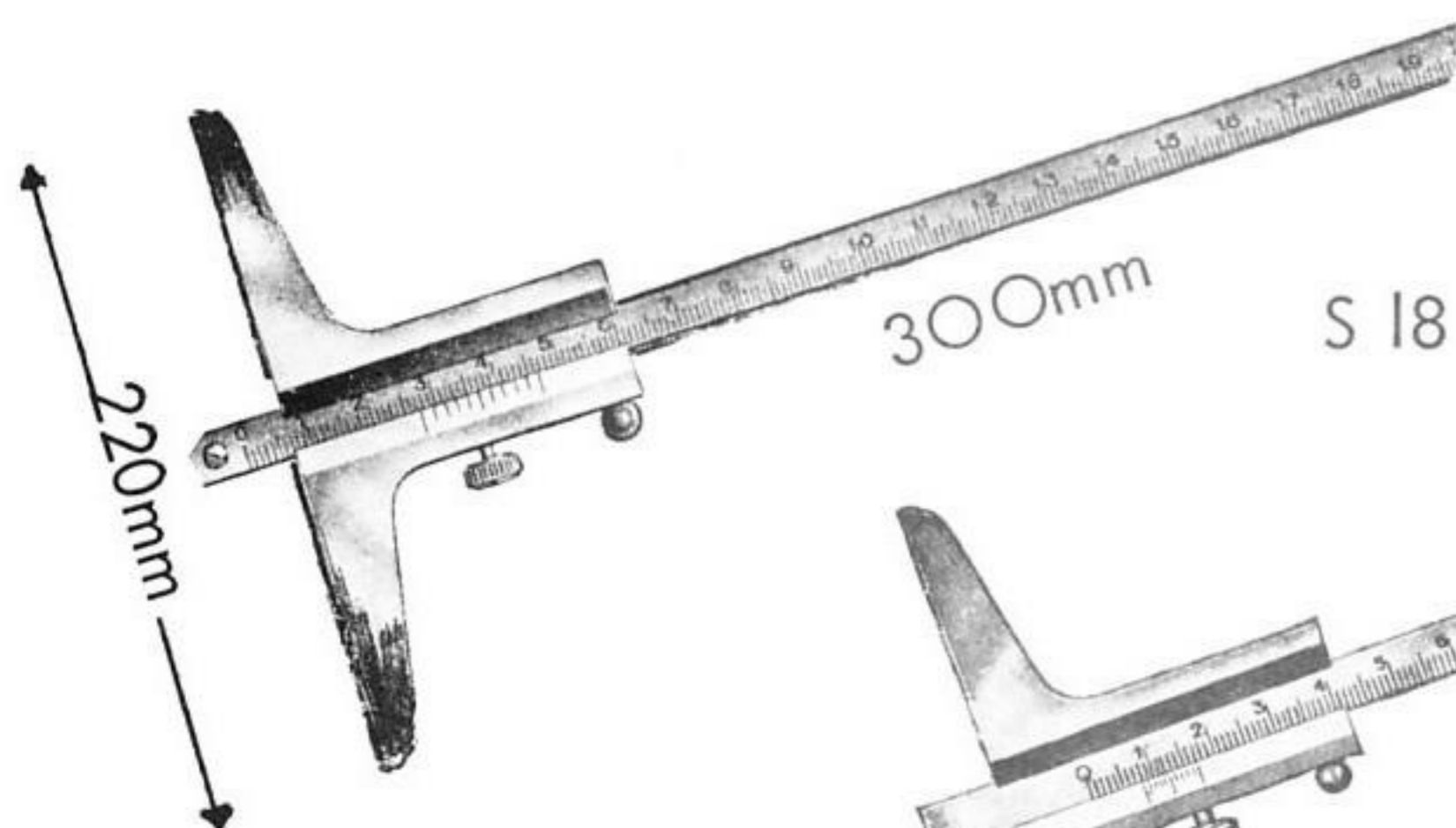

300mm

S 18

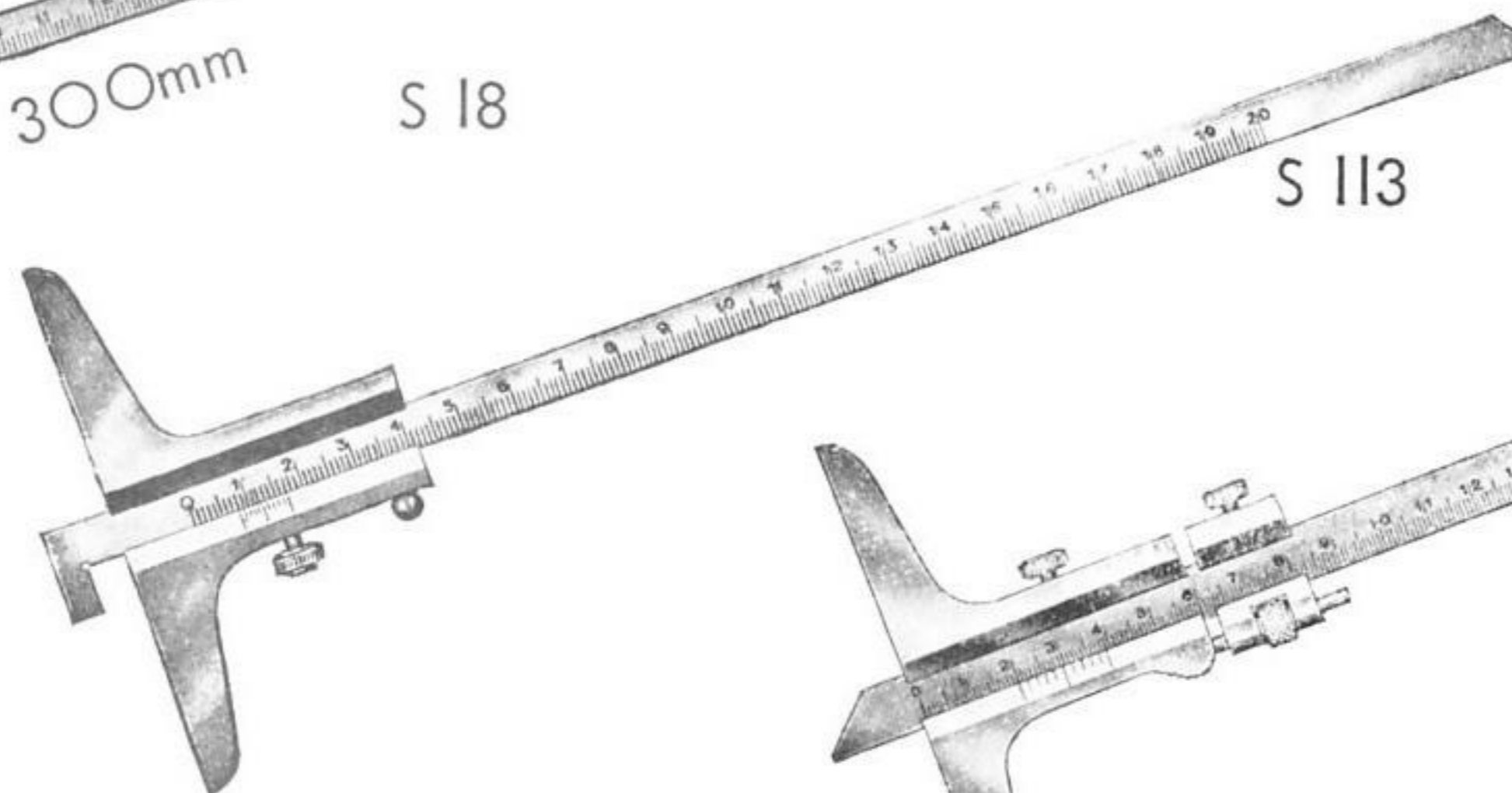

S 113

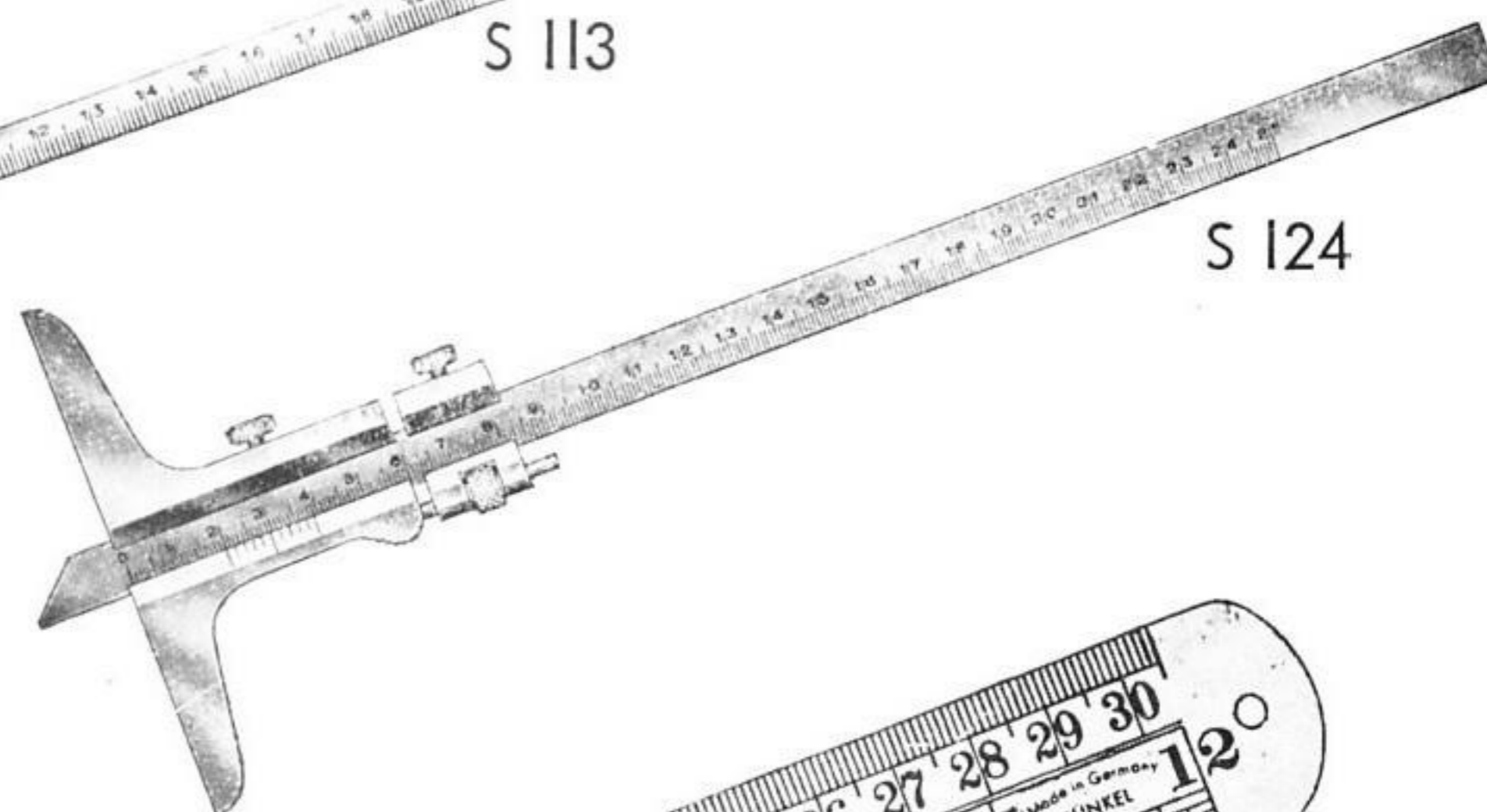

S 124

N 3 - 500

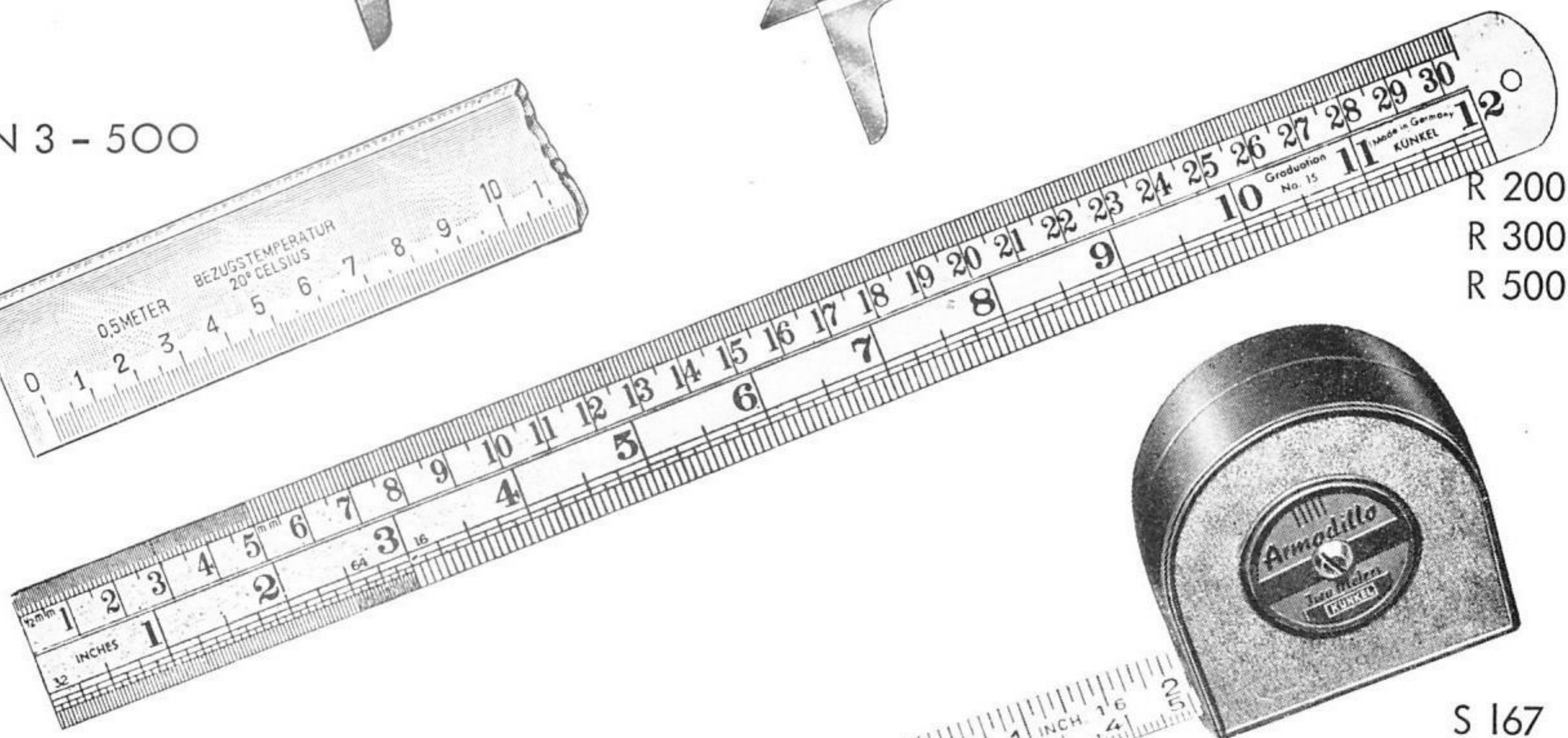
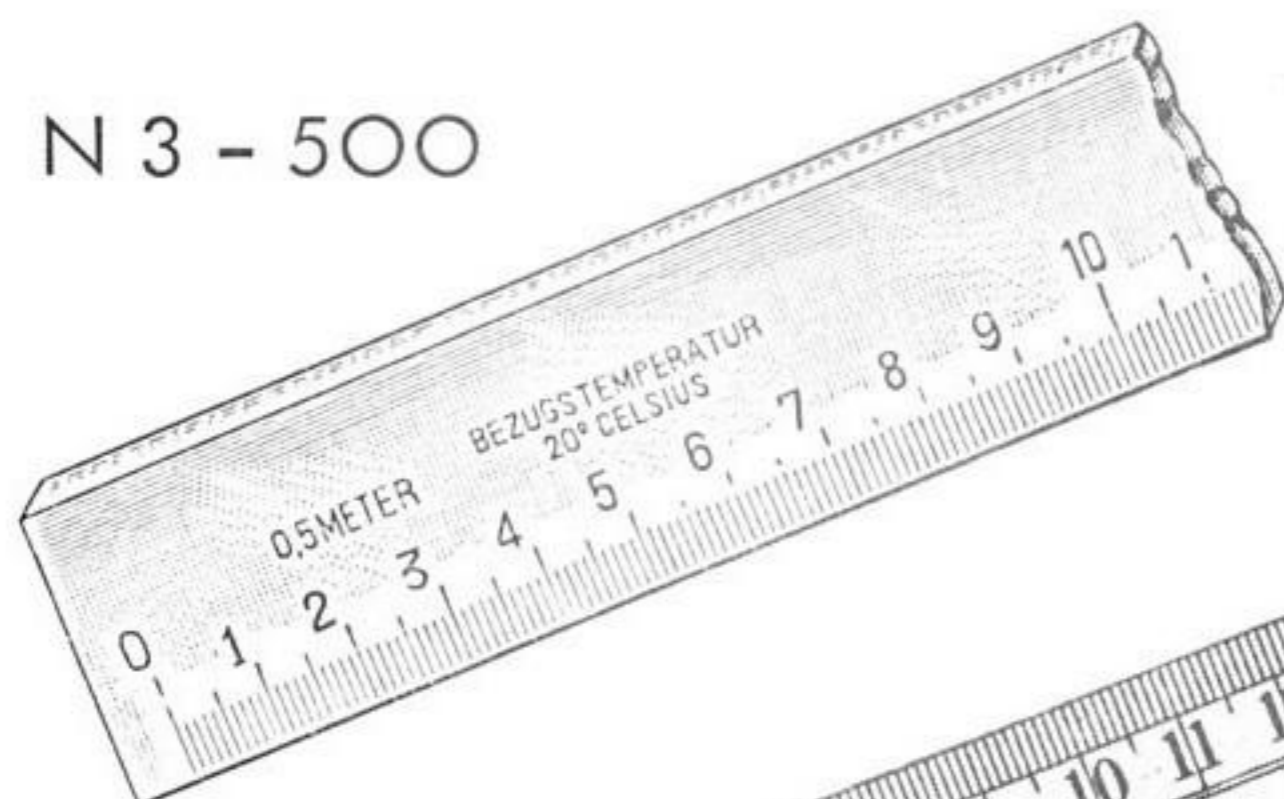

- R 200
- R 300
- R 500

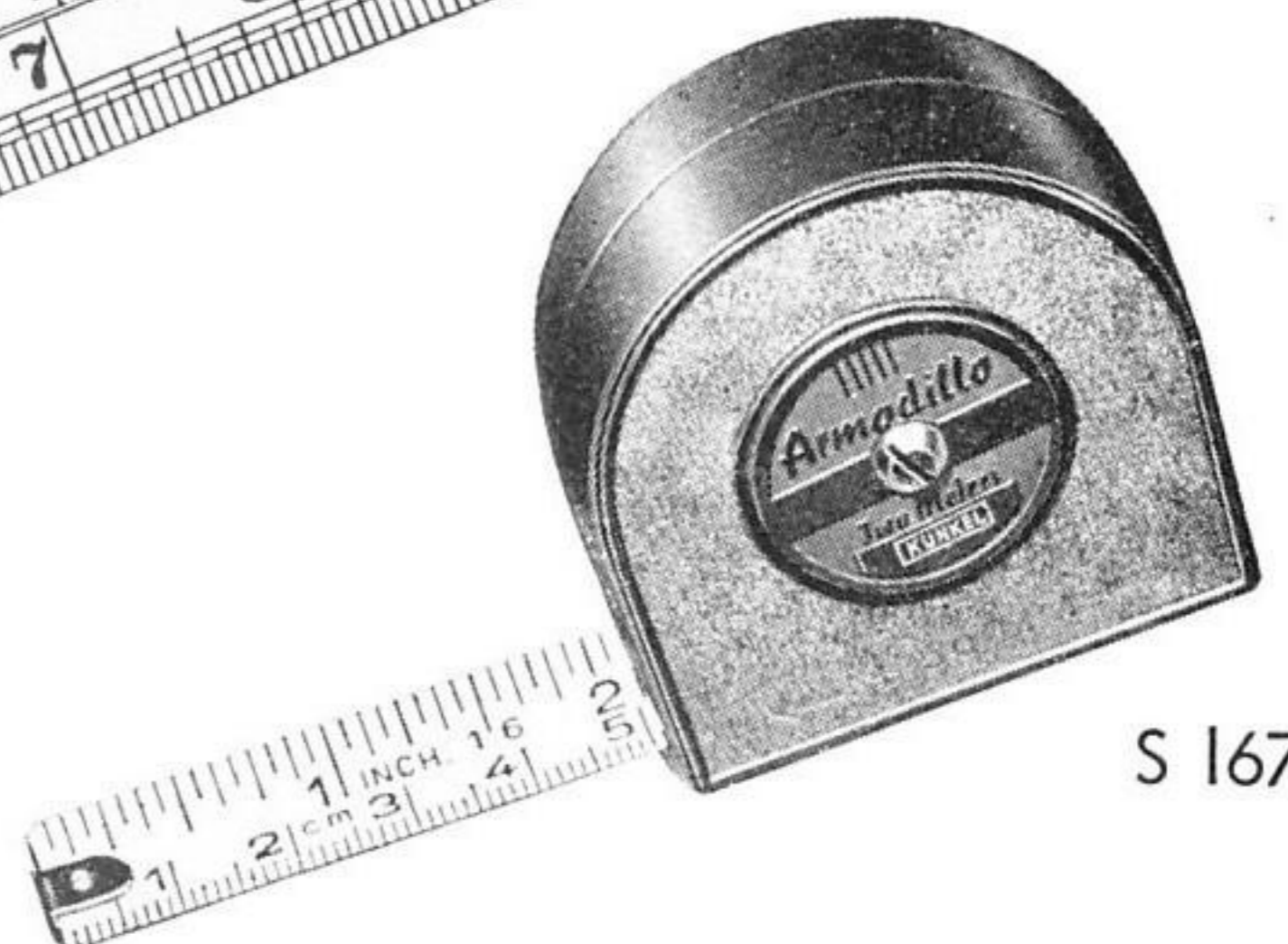

S 167

Special TOOLS

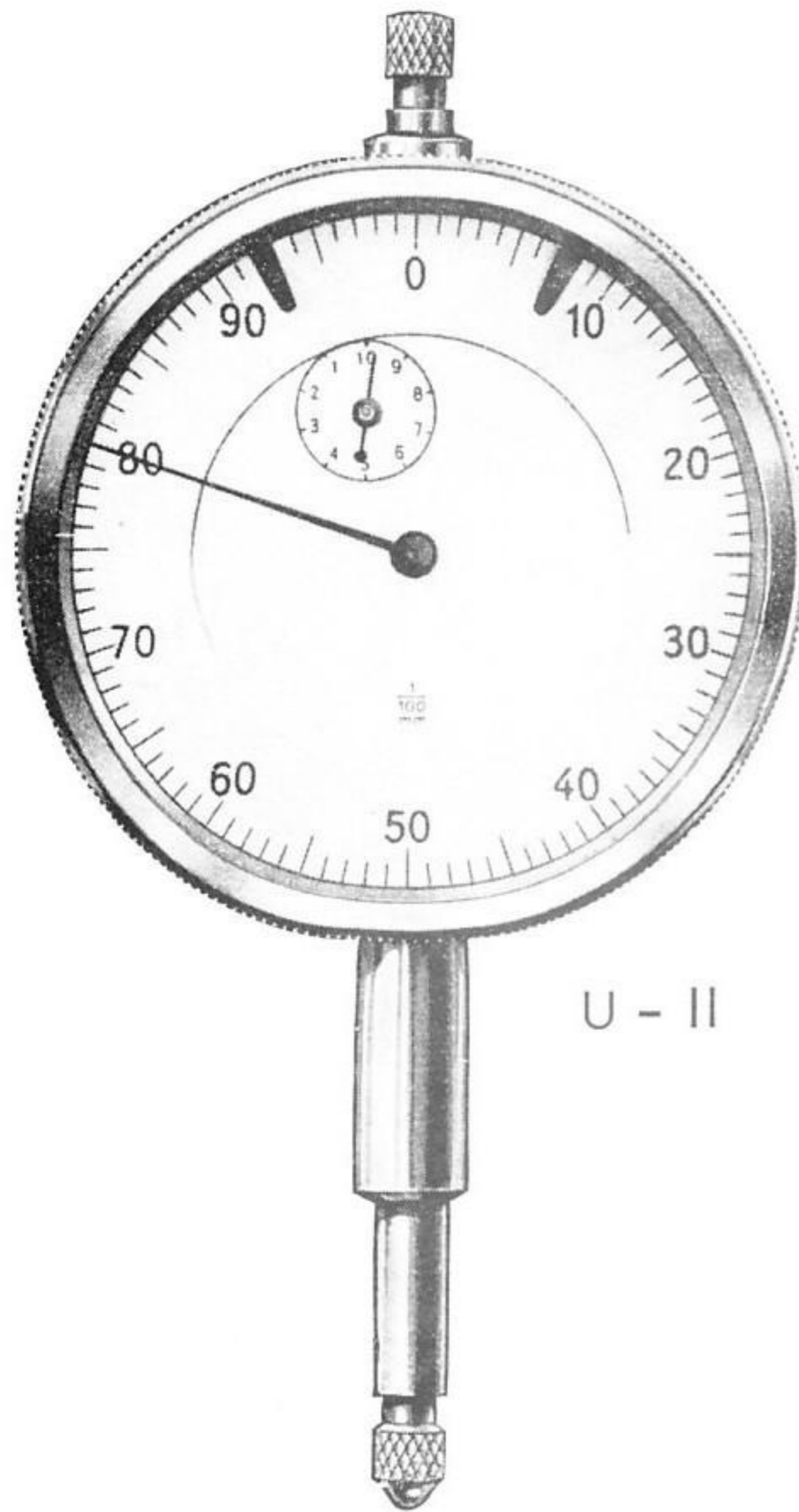

U - II

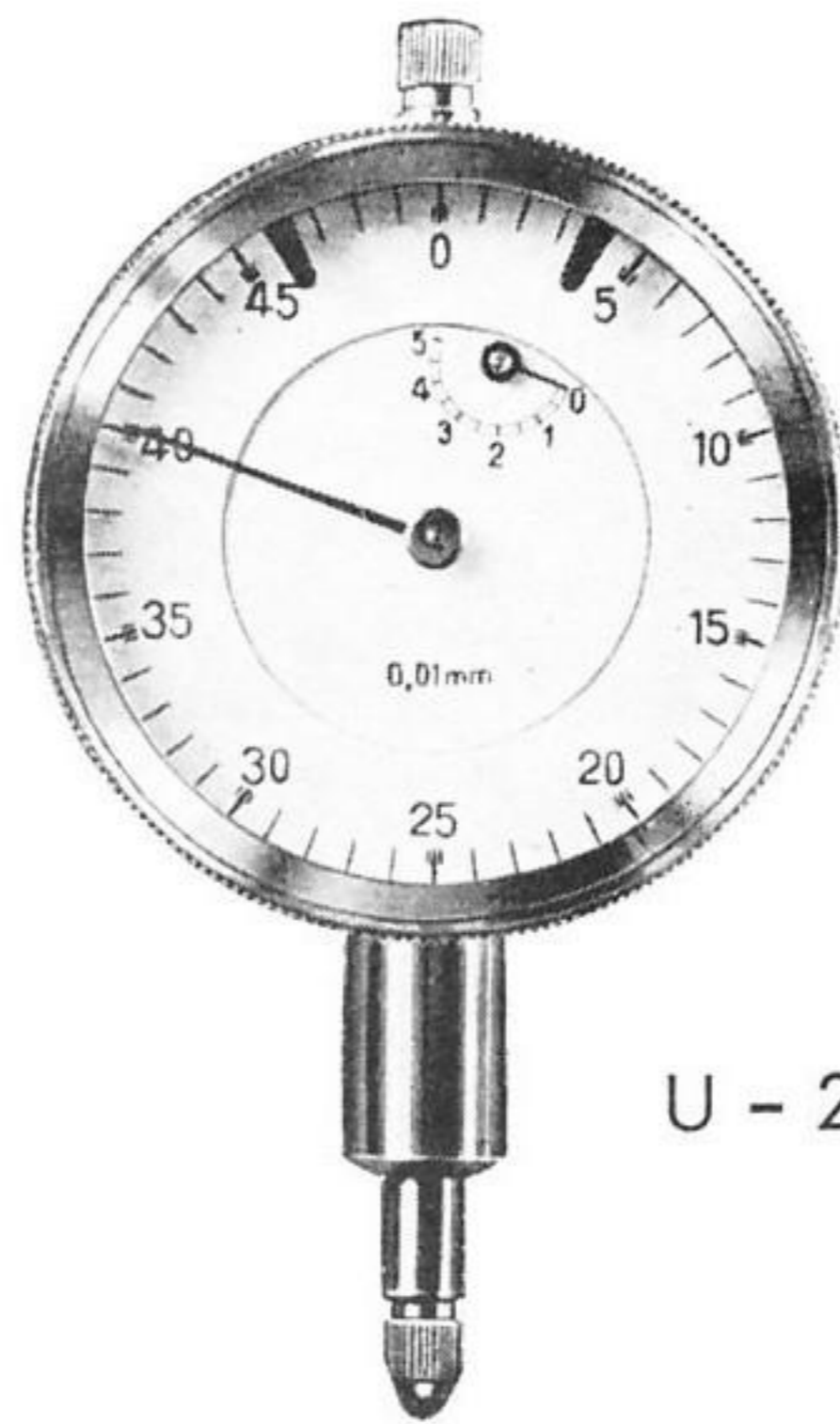

U - 2

EXTENSIONS



- E 3 (3mm)
- E 6 (6mm)
- E 14 (14mm)
- E 18 (18mm)
- E 21 (21mm)
- E 28 (28mm)



E 18 T
E 30 T
E 52 T



E 22 T
E 85 T



E 6 T

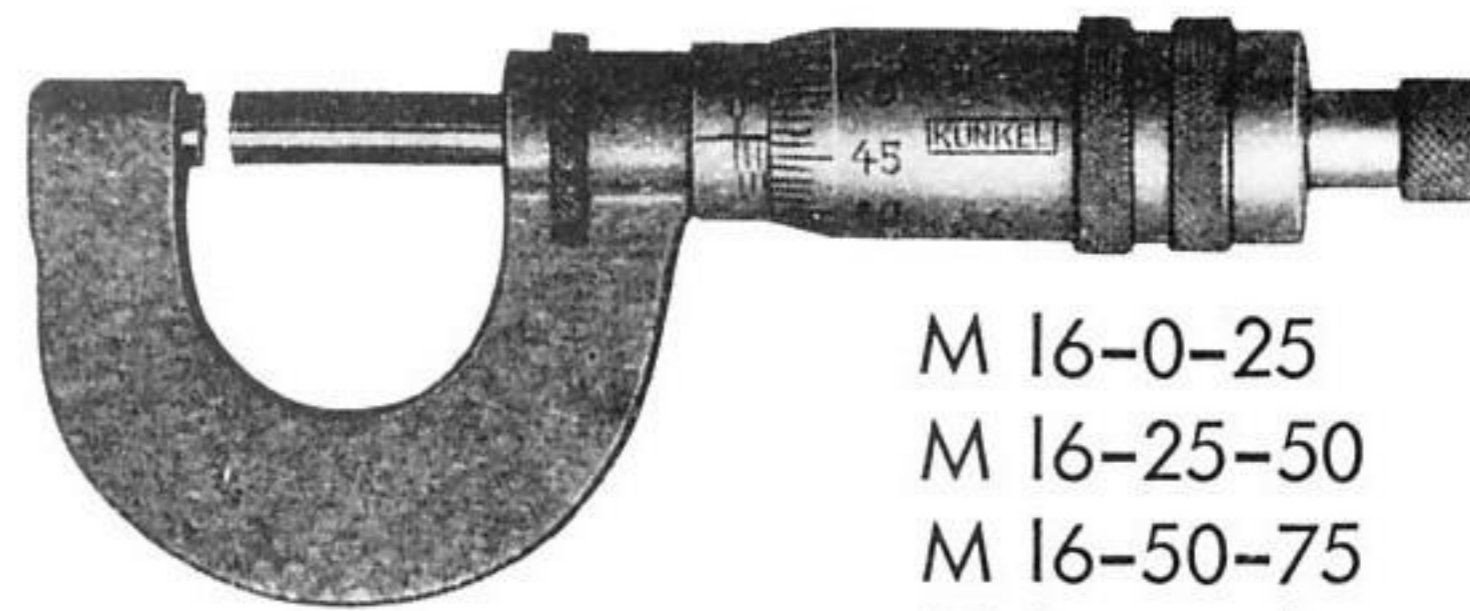

- M 16-0-25
- M 16-25-50
- M 16-50-75
- M 16-75-100

IN WOODEN CASE

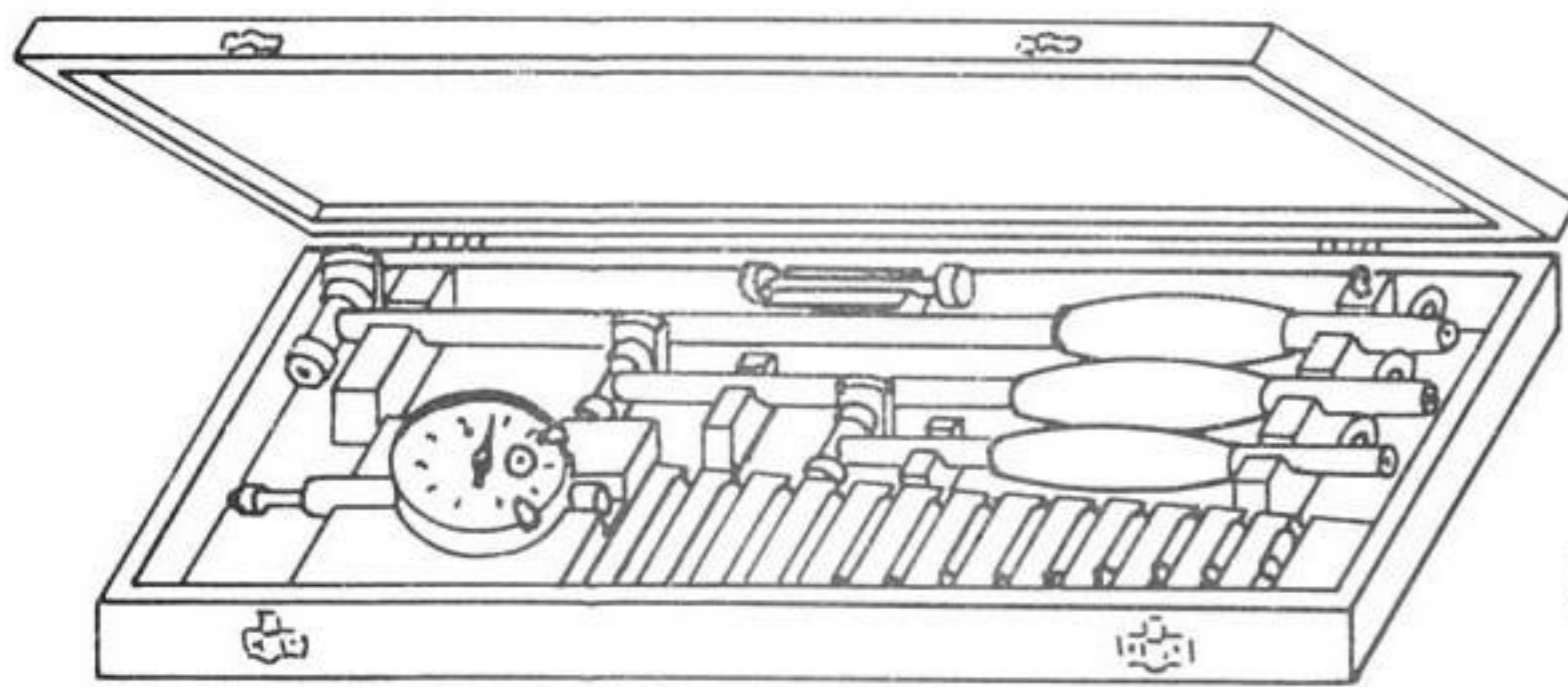

UG 74 - 3

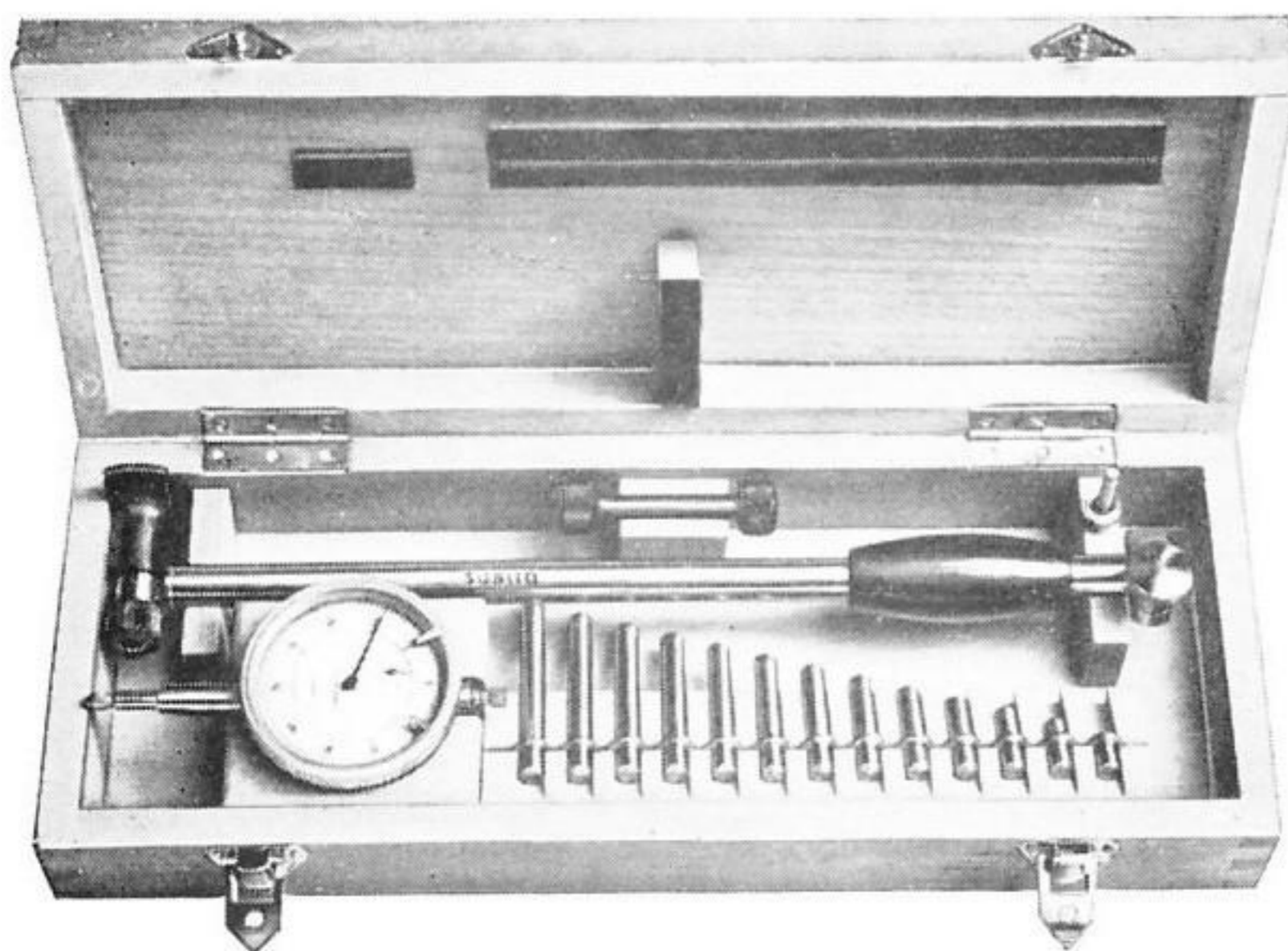

UG 74 - 2

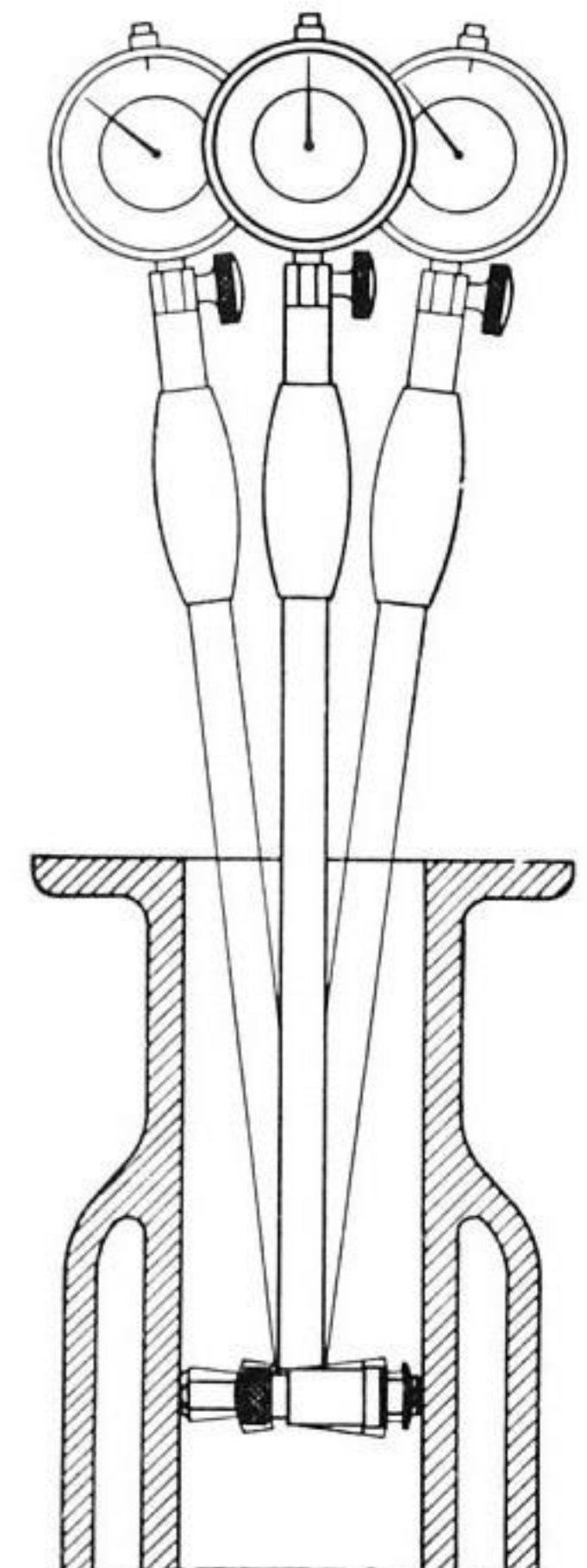
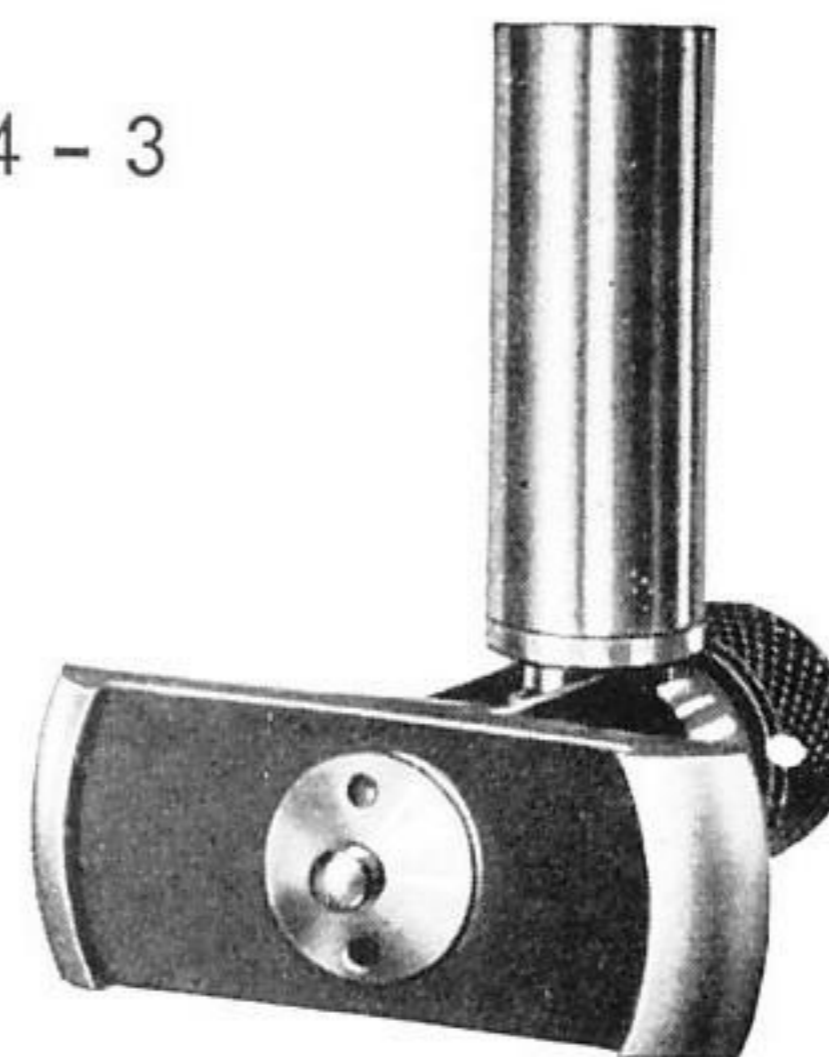

Special TOOLS

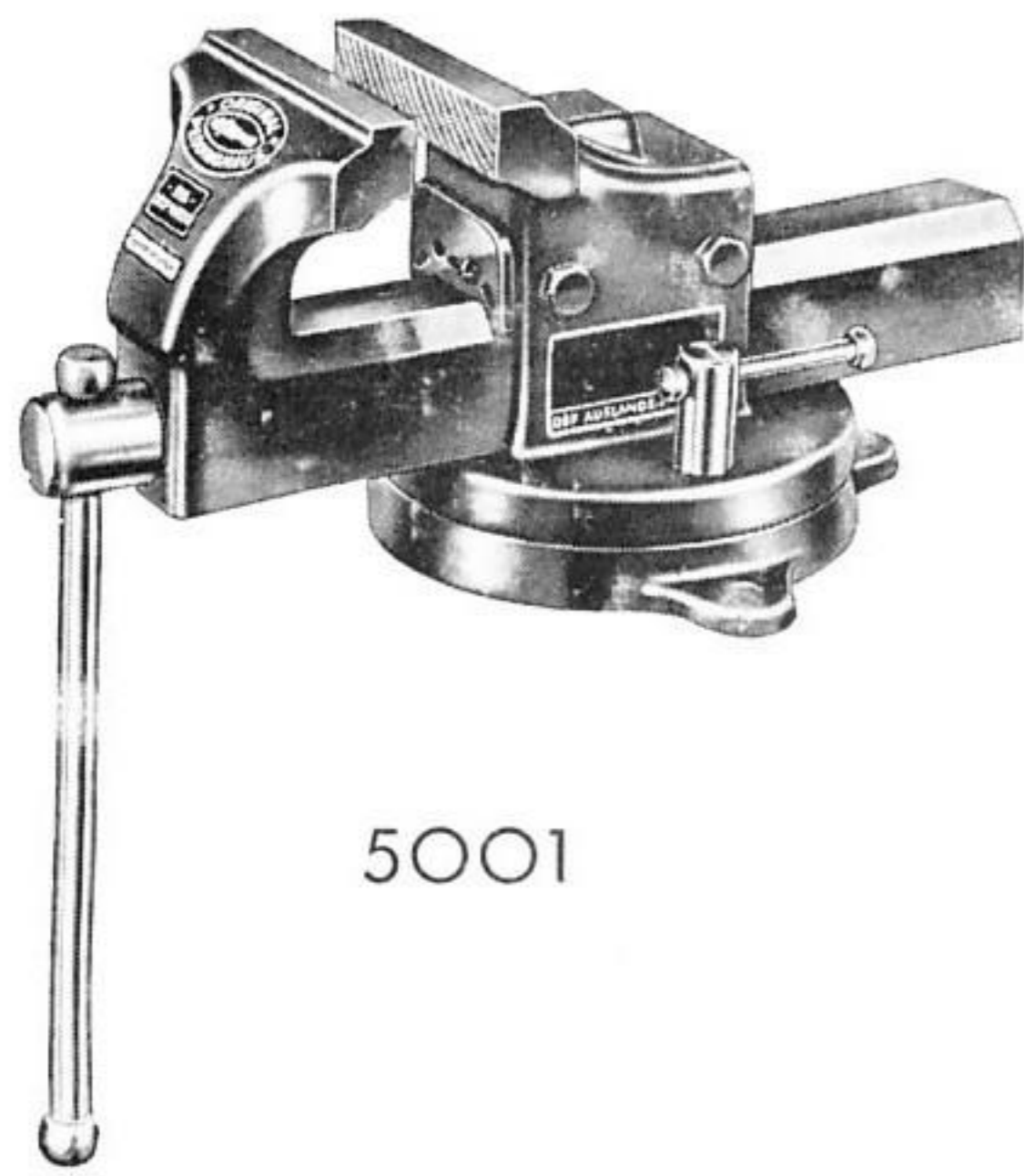

5001

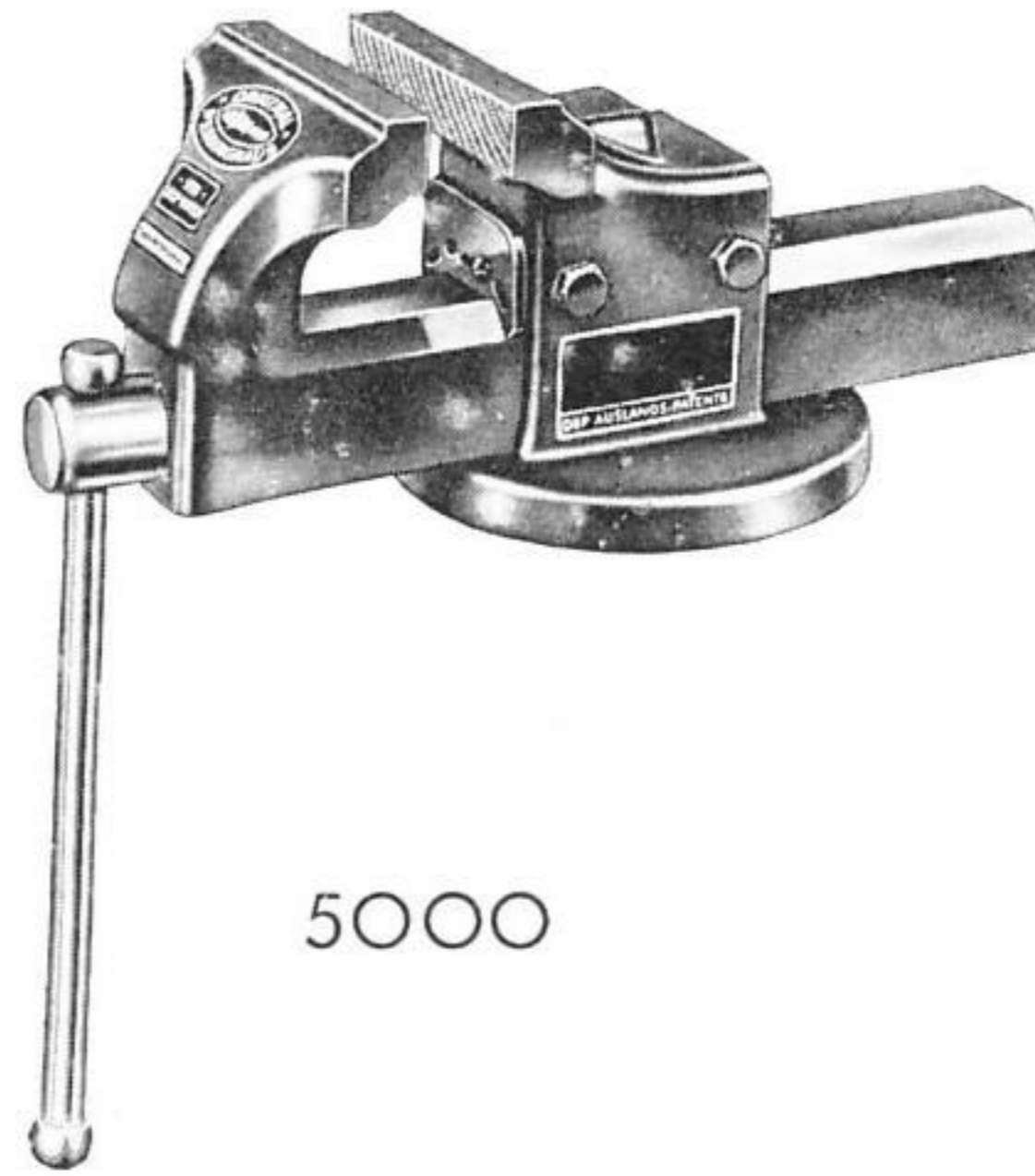

5000

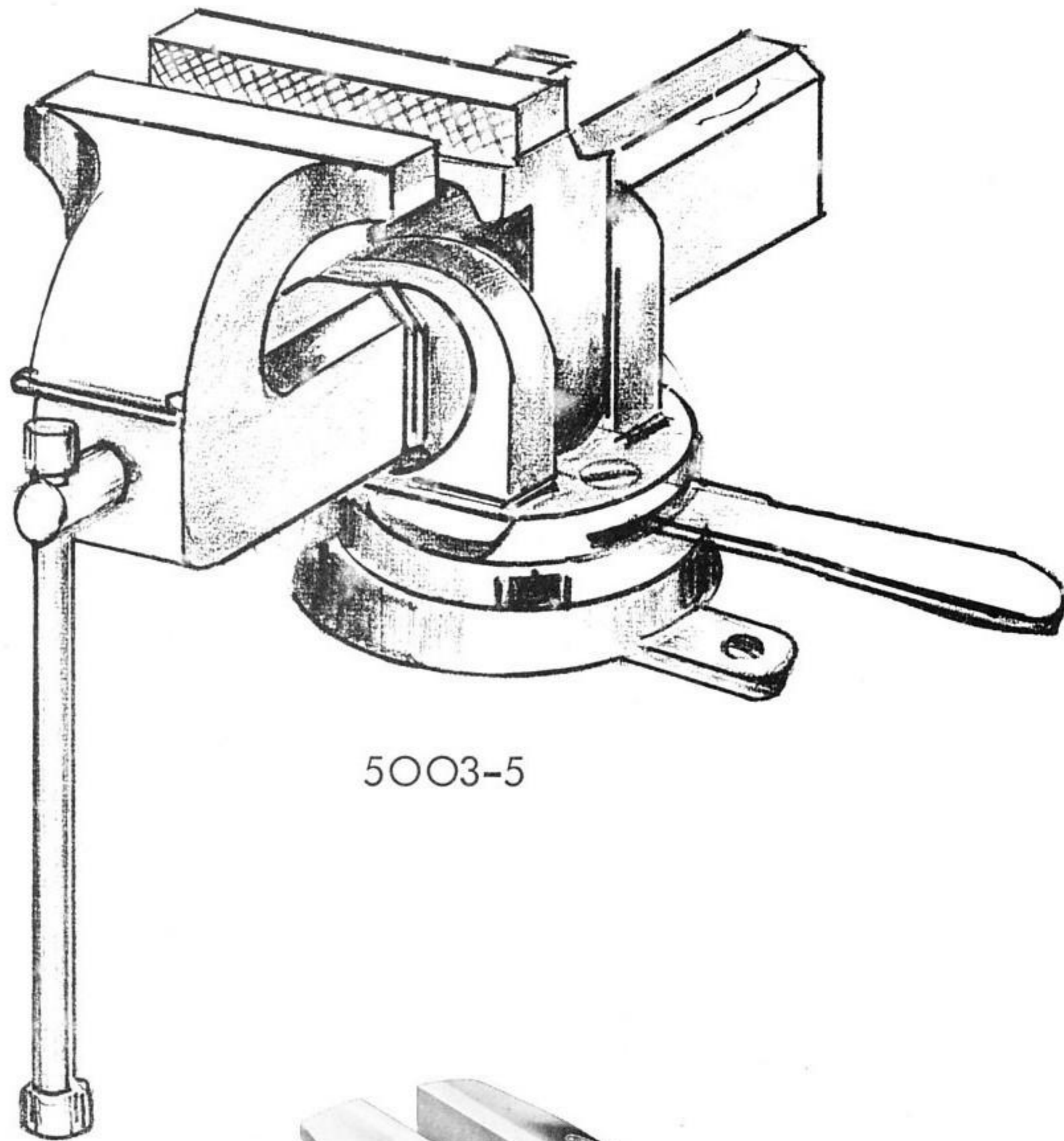
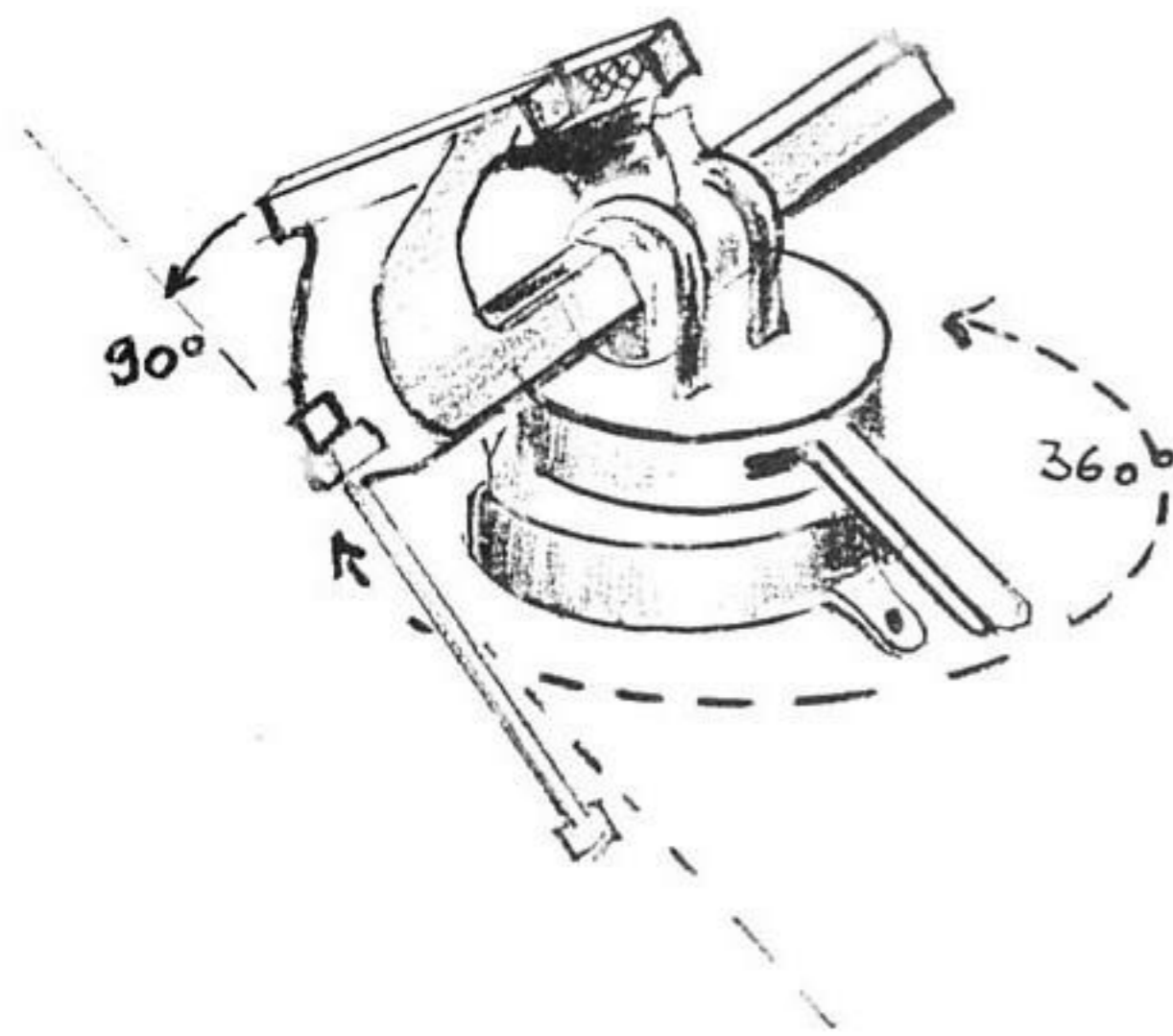
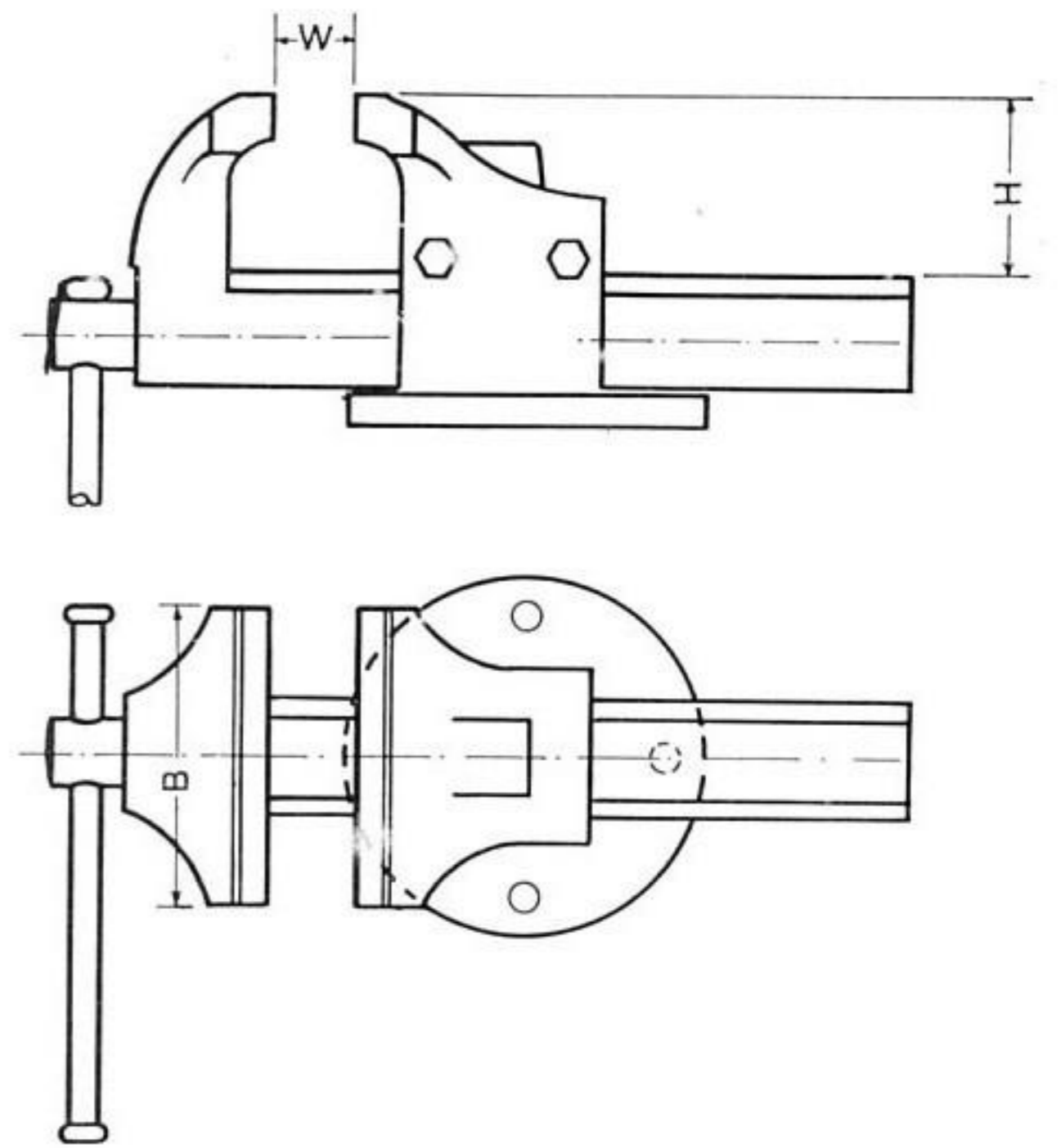

5003-5

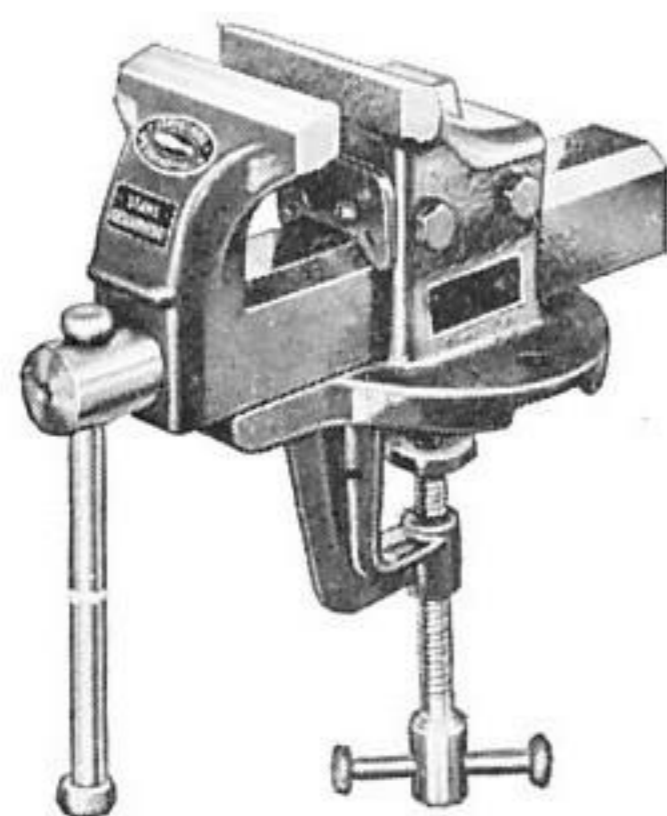

5002



5004

DESCRIPTION ON PAGE: 55

Bushing Dimensions for VW 282b

<u>NUMBER</u>	<u>INNER DIAMETER</u>	<u>OUTER DIAMETER</u>
282 b/4	37.0 mm	43.0 mm
282 b/6	37.0 mm	50.0 mm
282 b/7	43.0 mm	50.0 mm
282 b/8	43.0 mm	50.0 mm

Bushing Dimensions for VW 282d

2	33.0 mm	50.0 mm
4	35.0 mm	50.0 mm
10	43.0 mm	50.0 mm
11	32.0 mm	50.0 mm
12	43.0 mm	50.0 mm
13	37.0 mm	50.0 mm
14	43.0 mm	50.0 mm
15	37.0 mm	50.0 mm
4	35.0 mm	50.0 mm

Bushing Dimensions for VW 282d 13/18

13	37.0 mm	50.0 mm
14	43.0 mm	50.0 mm
15	37.0 mm	50.0 mm

Special TOOLS

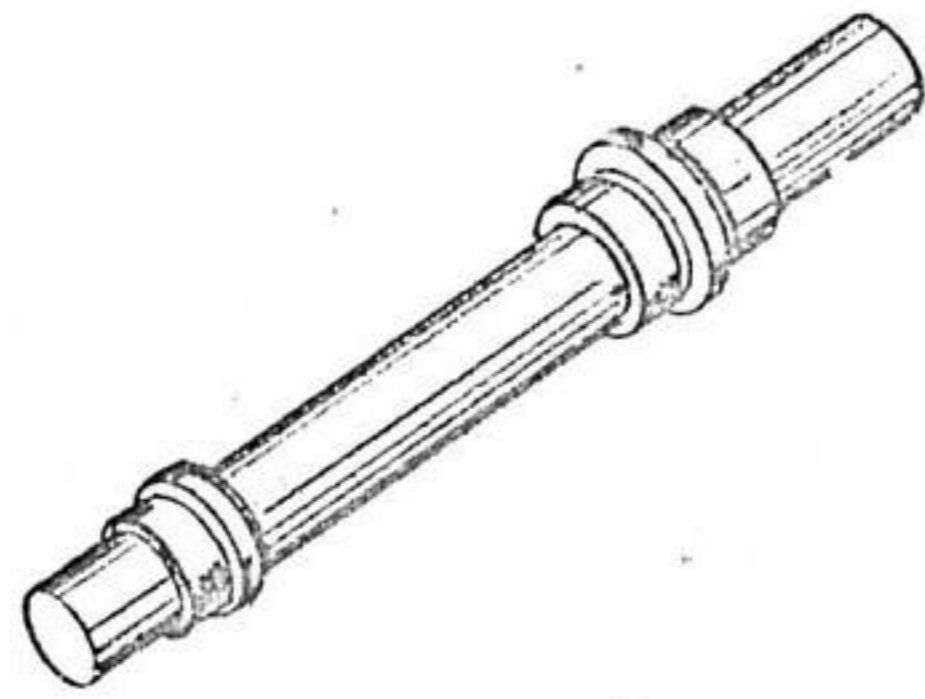

US 768

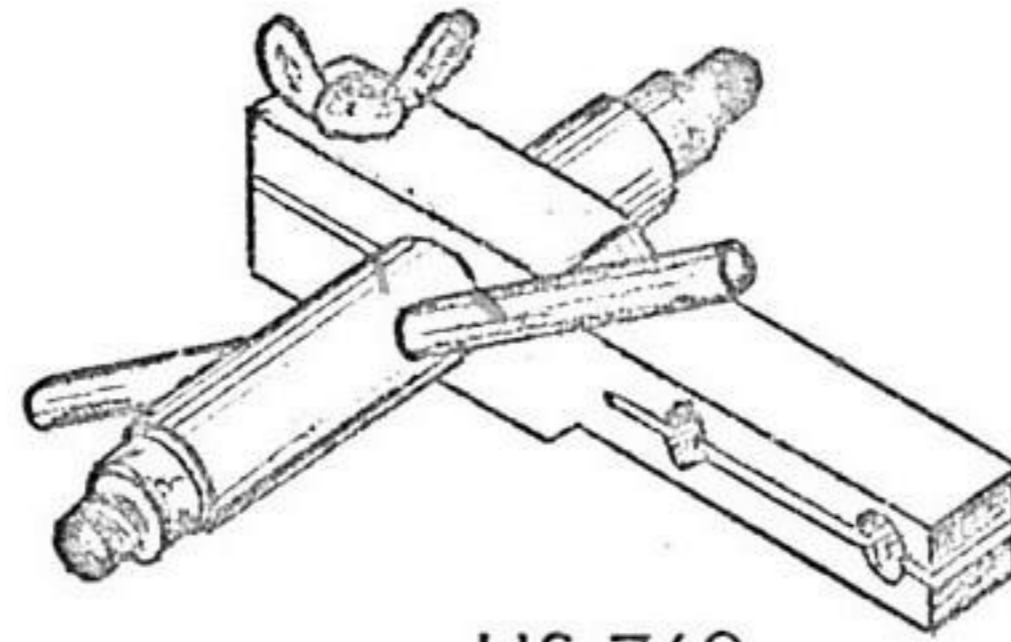

US 769

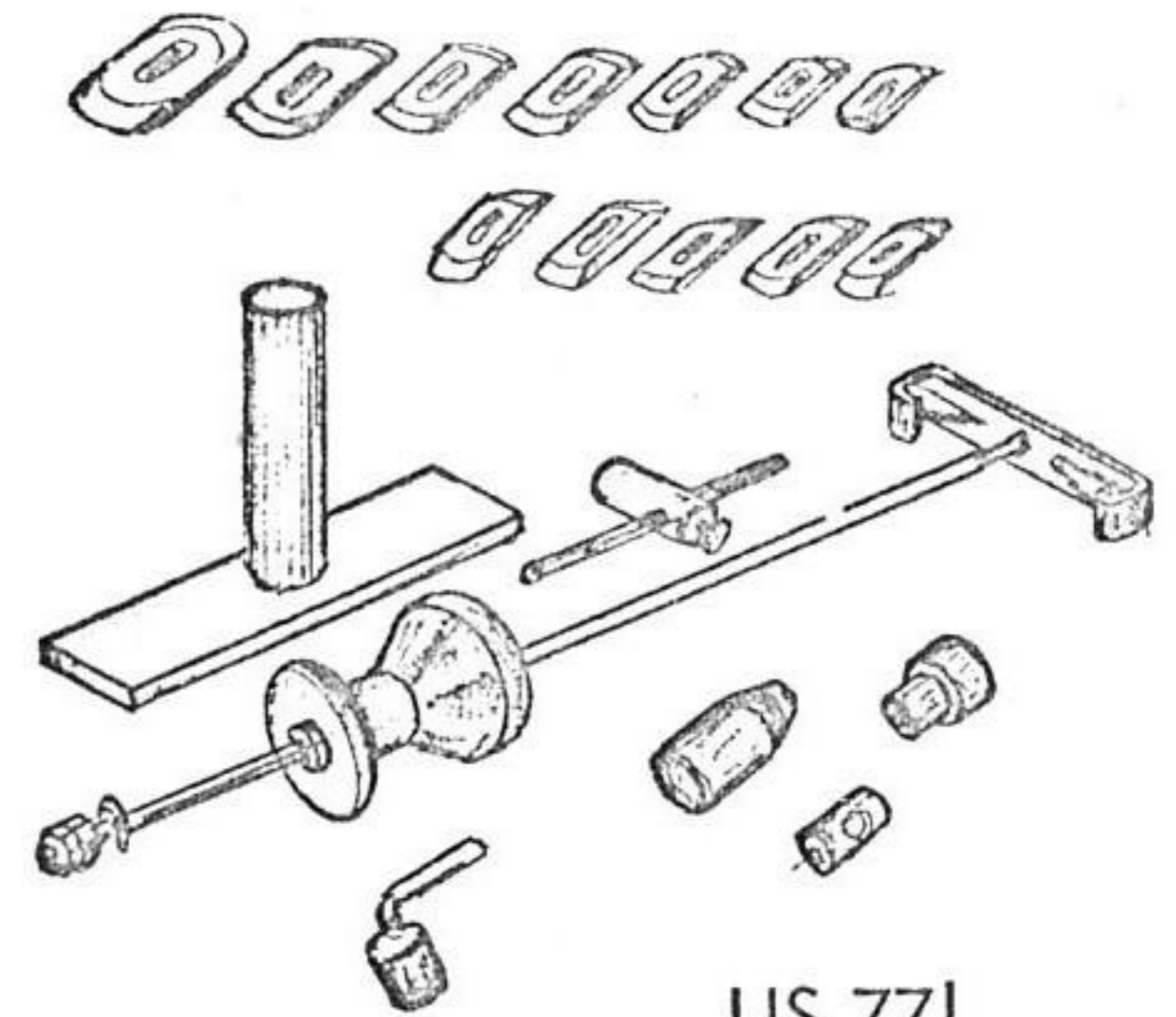

US 771

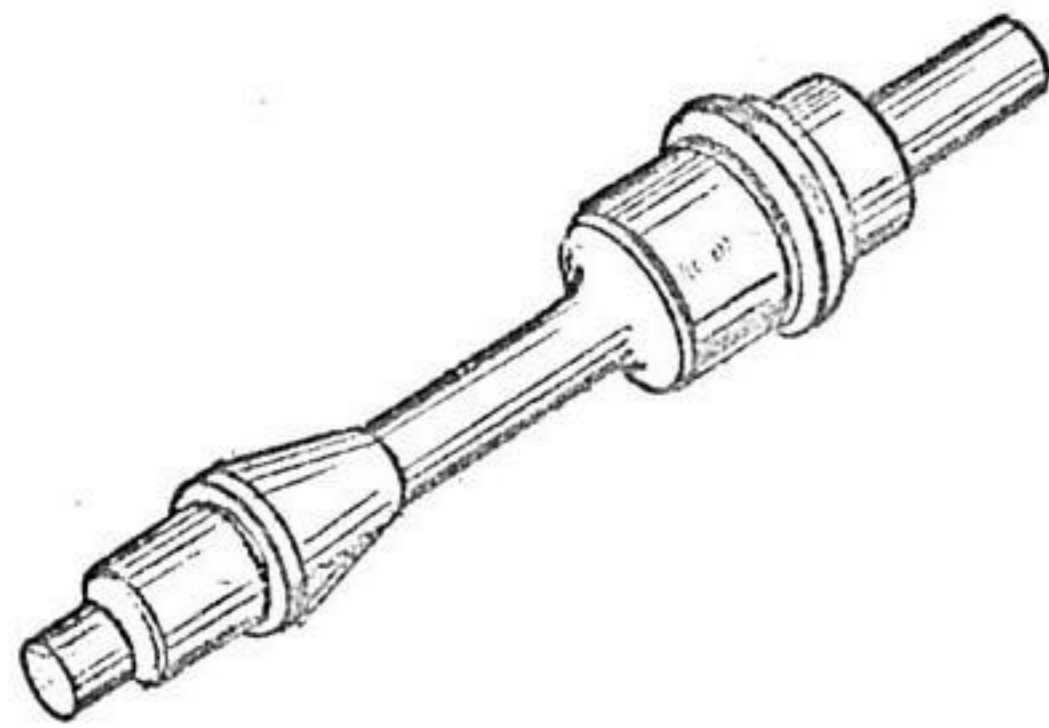

US 772

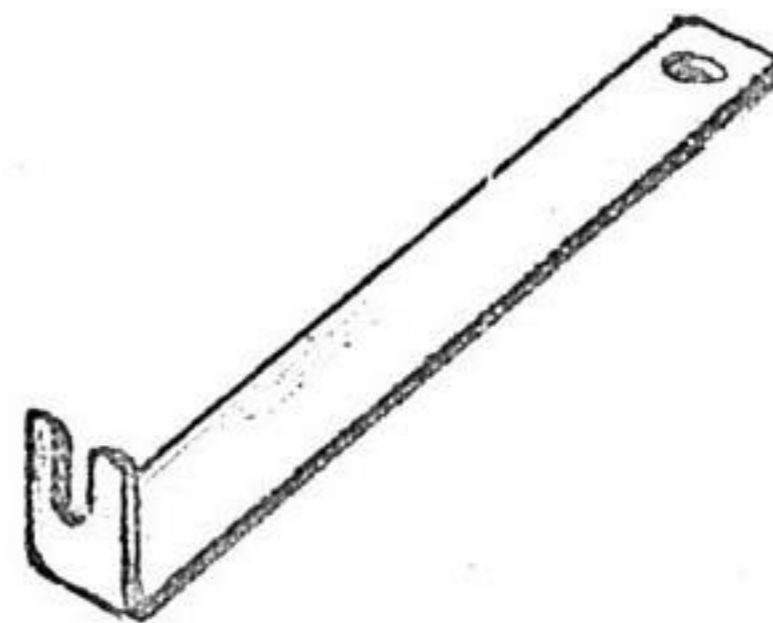

US 774

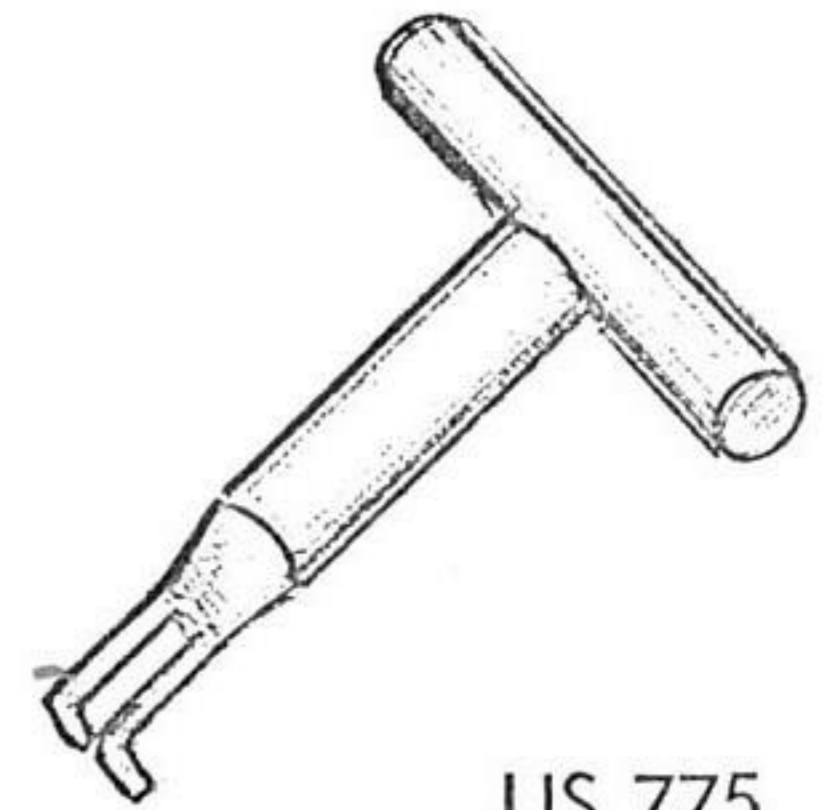

US 775

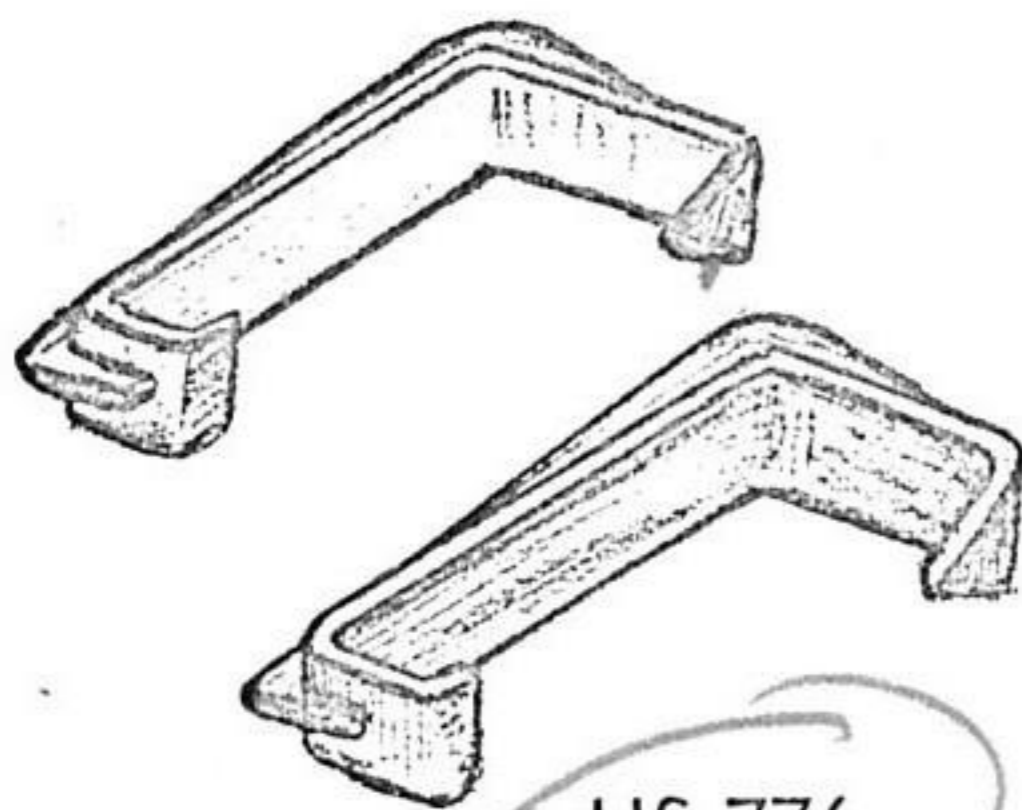

US 776

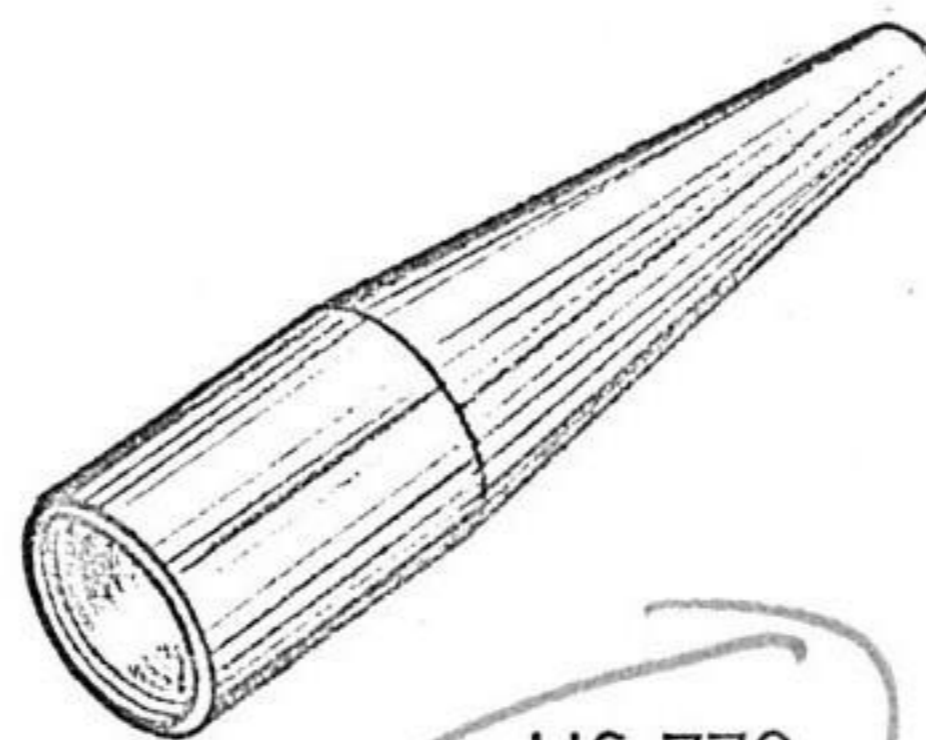

US 778

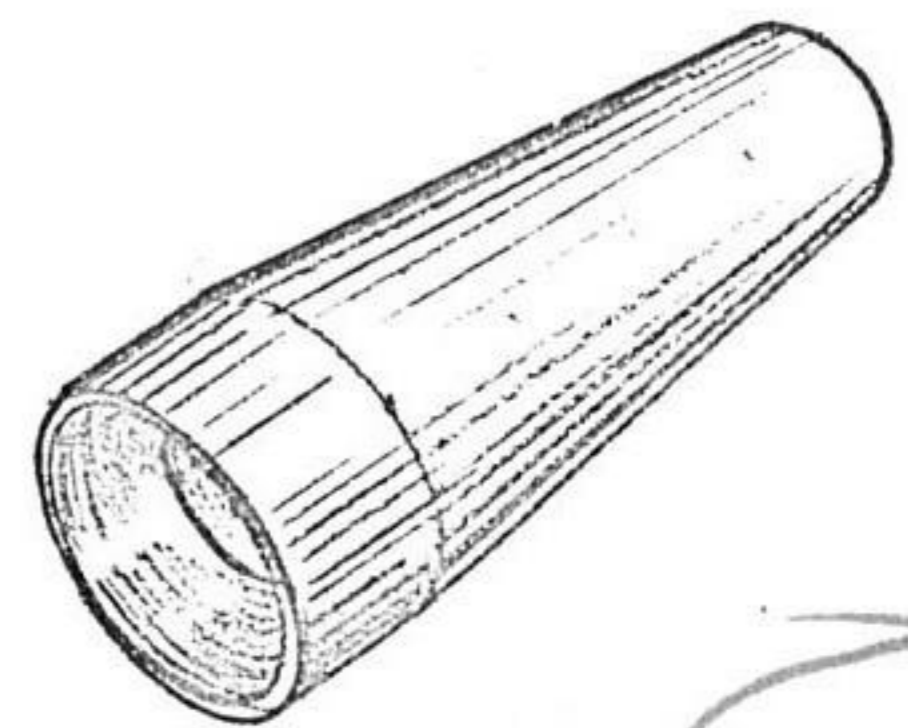

US 780-1

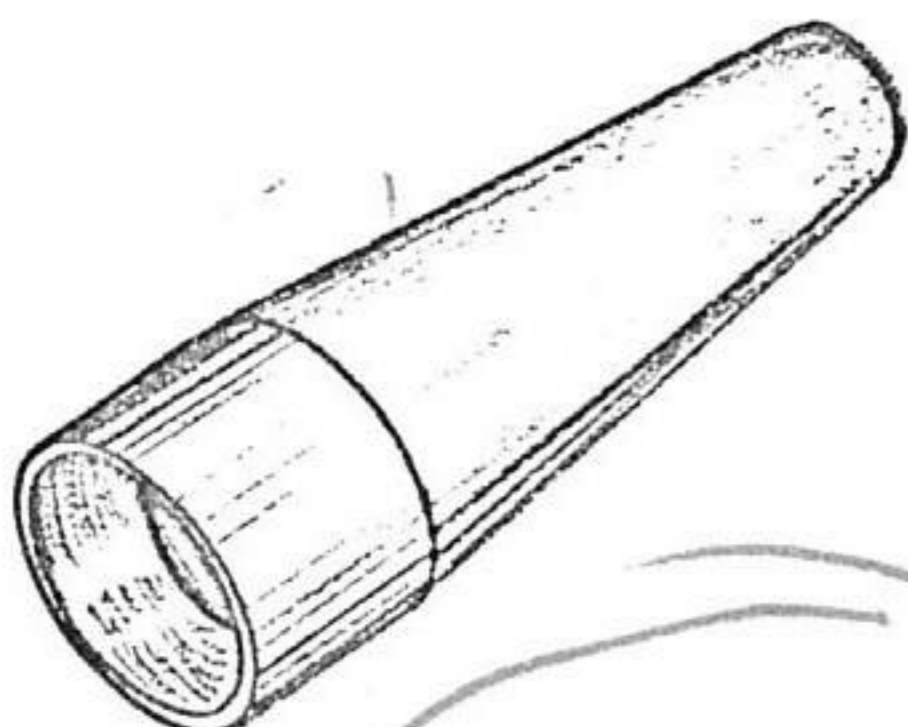

US 780-2

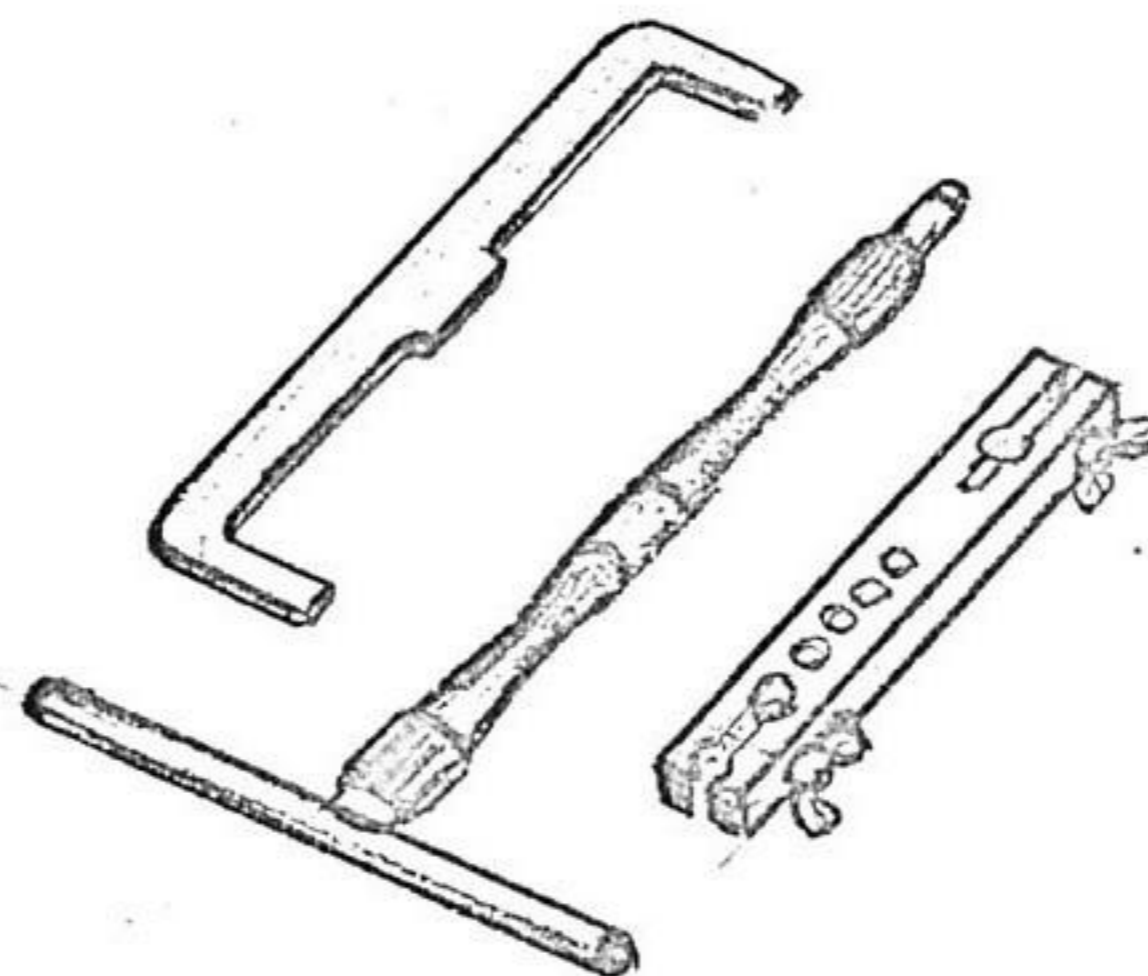

US 782

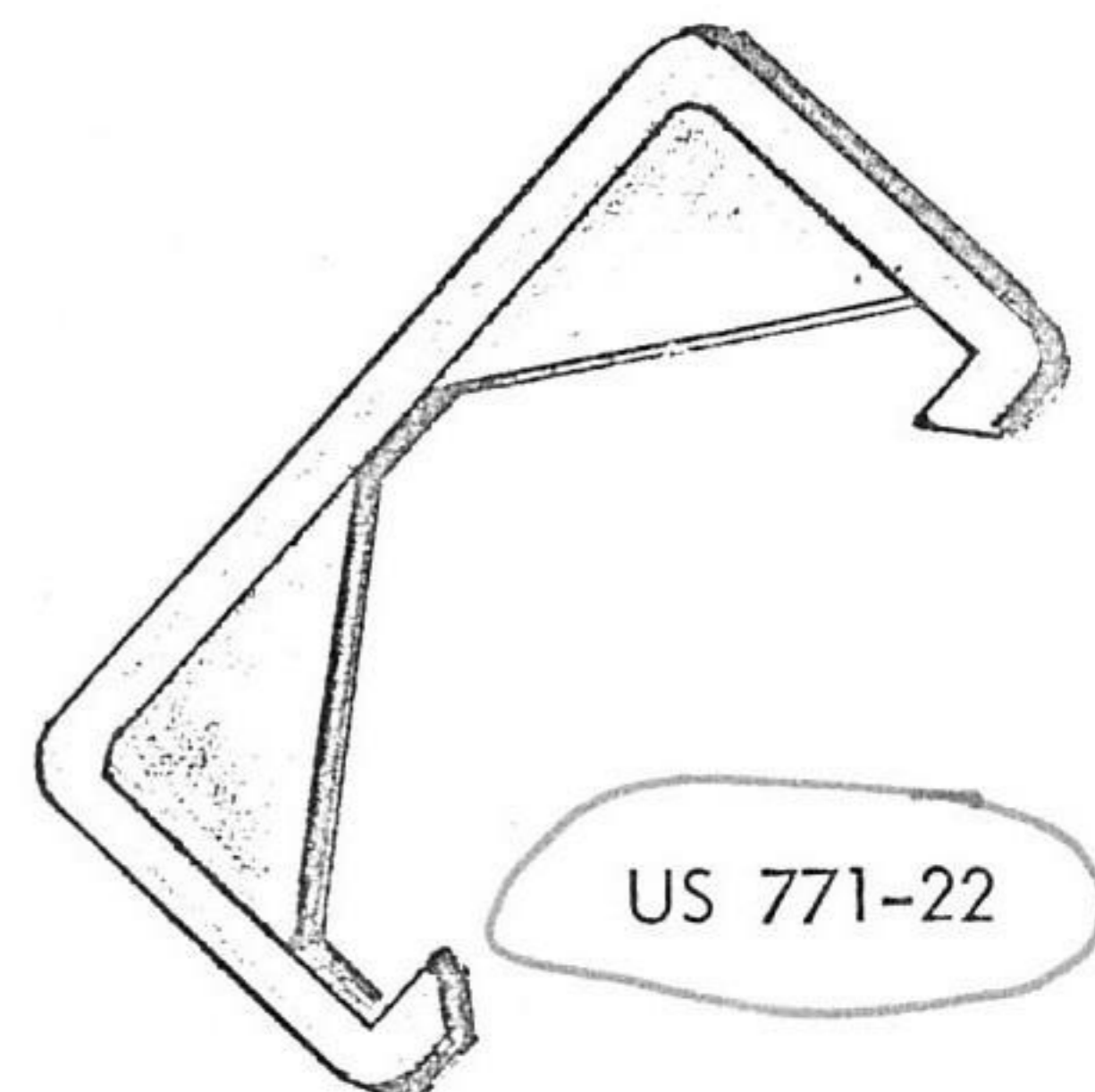

US 771-22

Special TOOLS

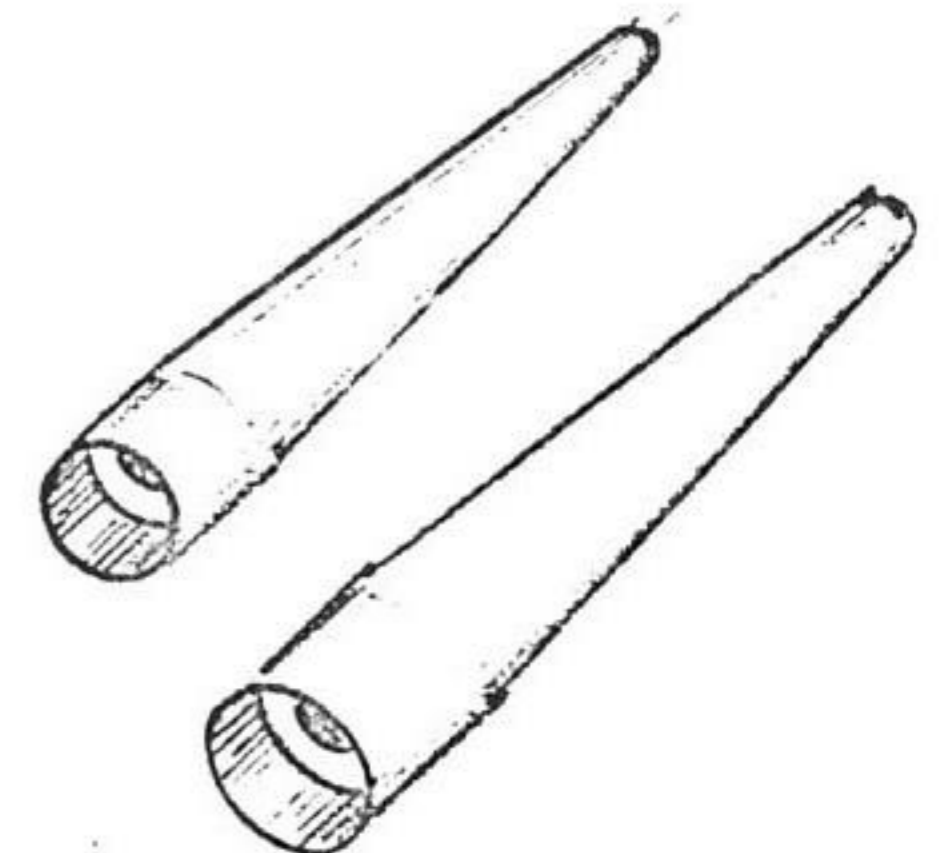
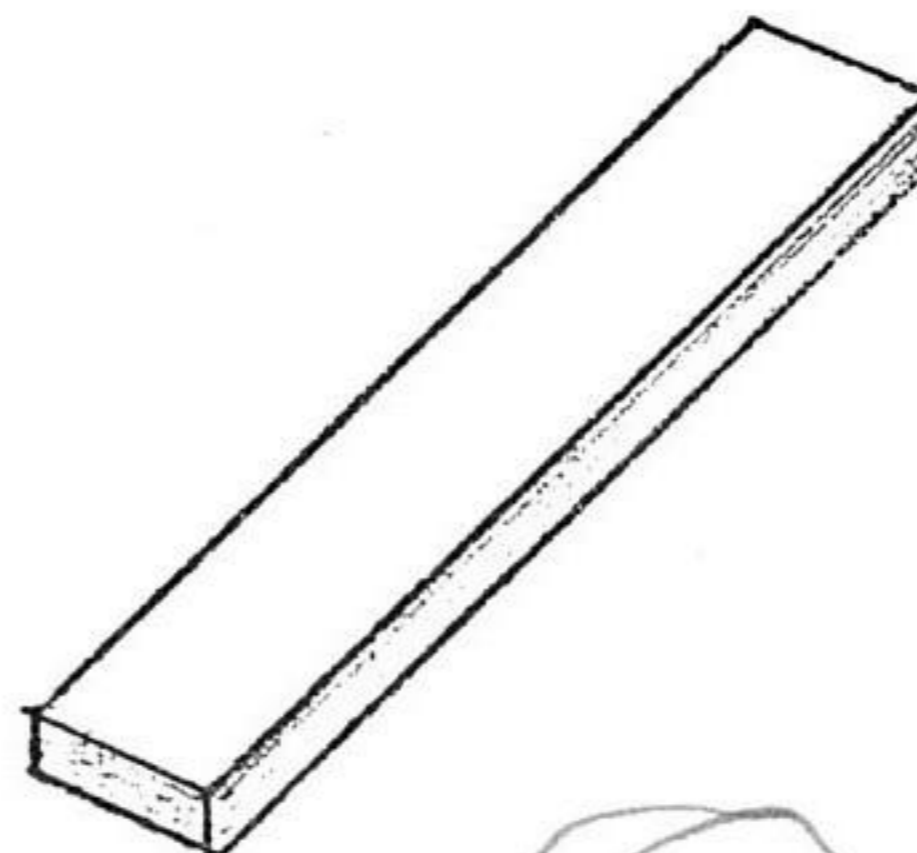
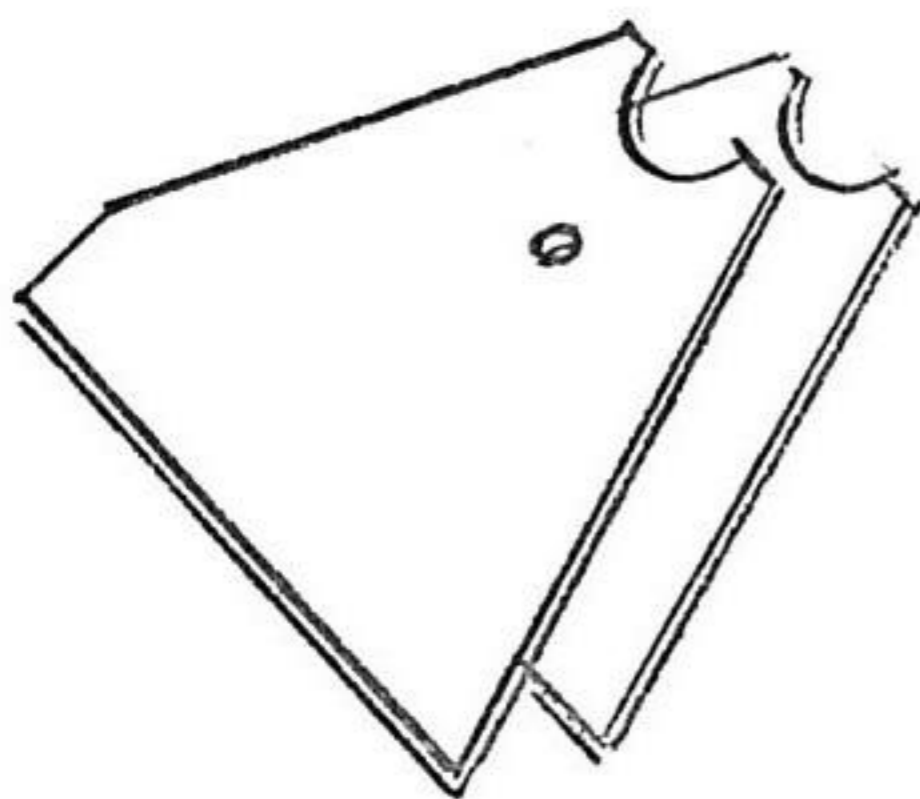
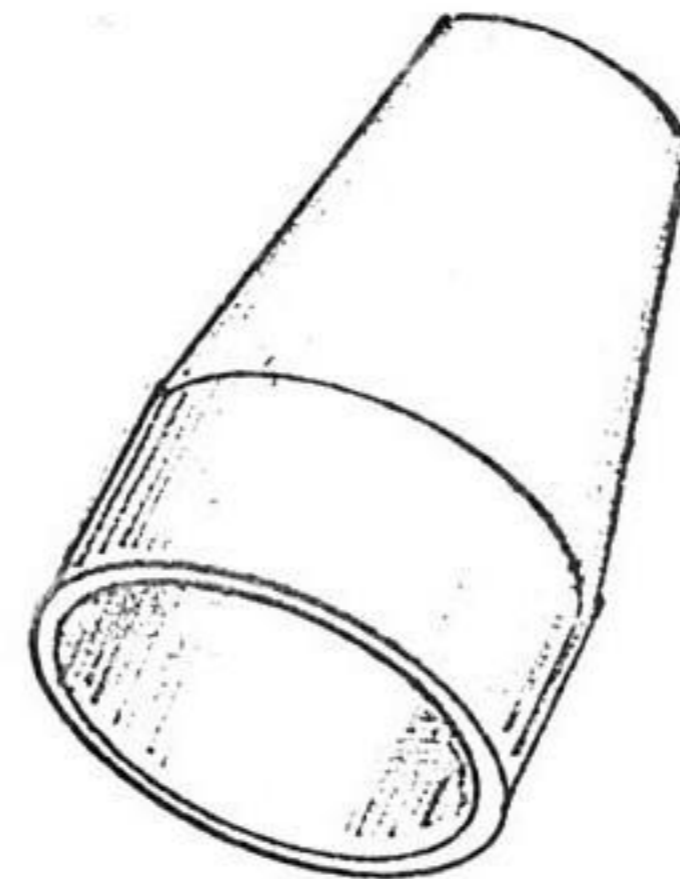
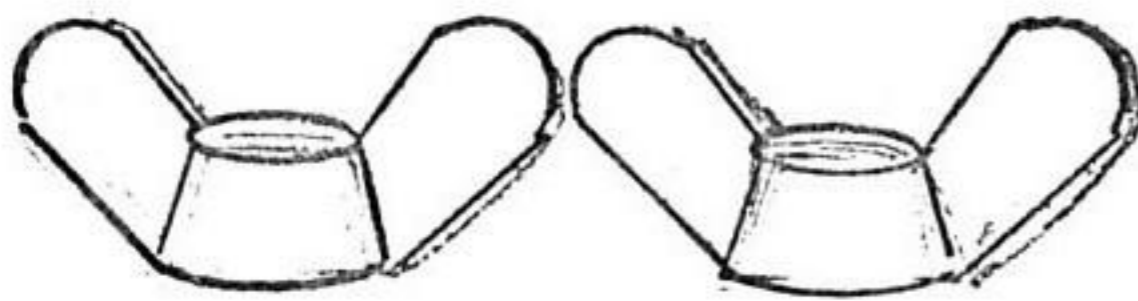
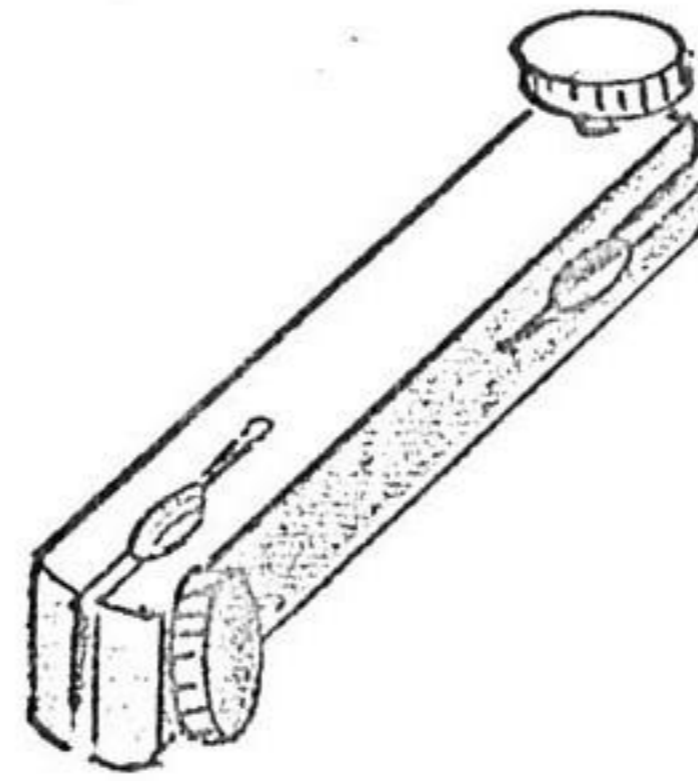
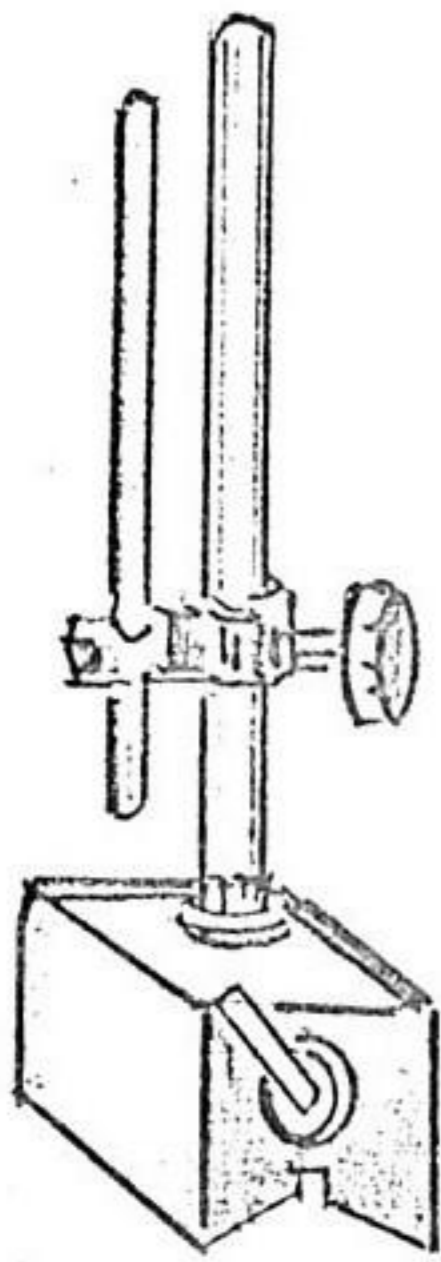
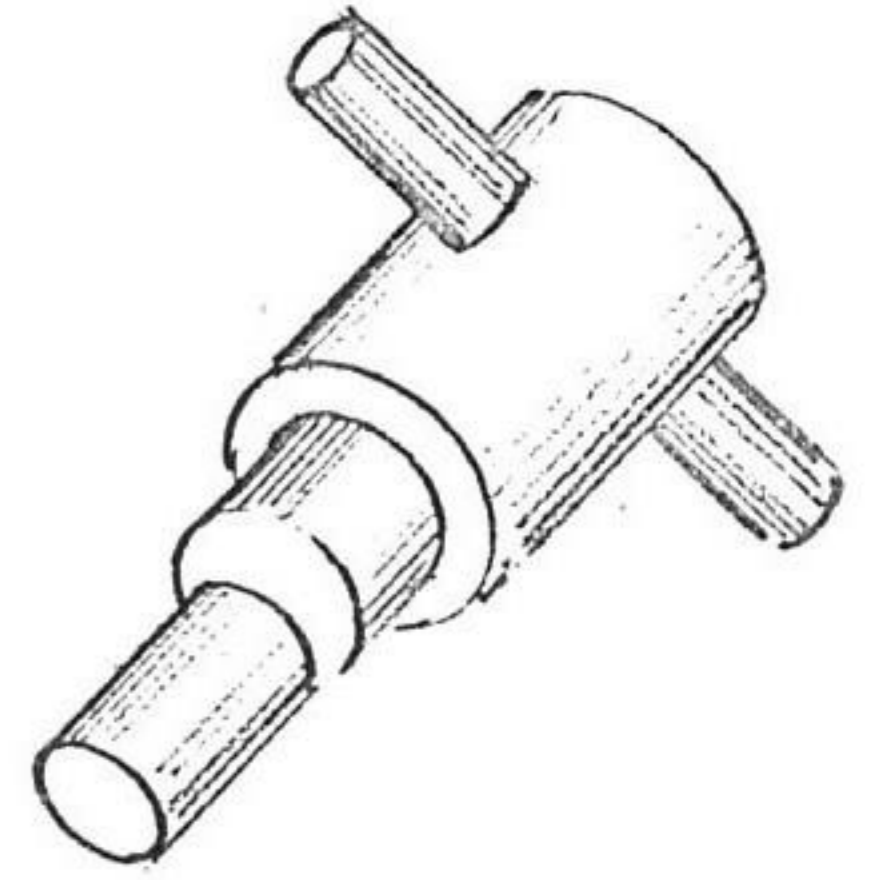
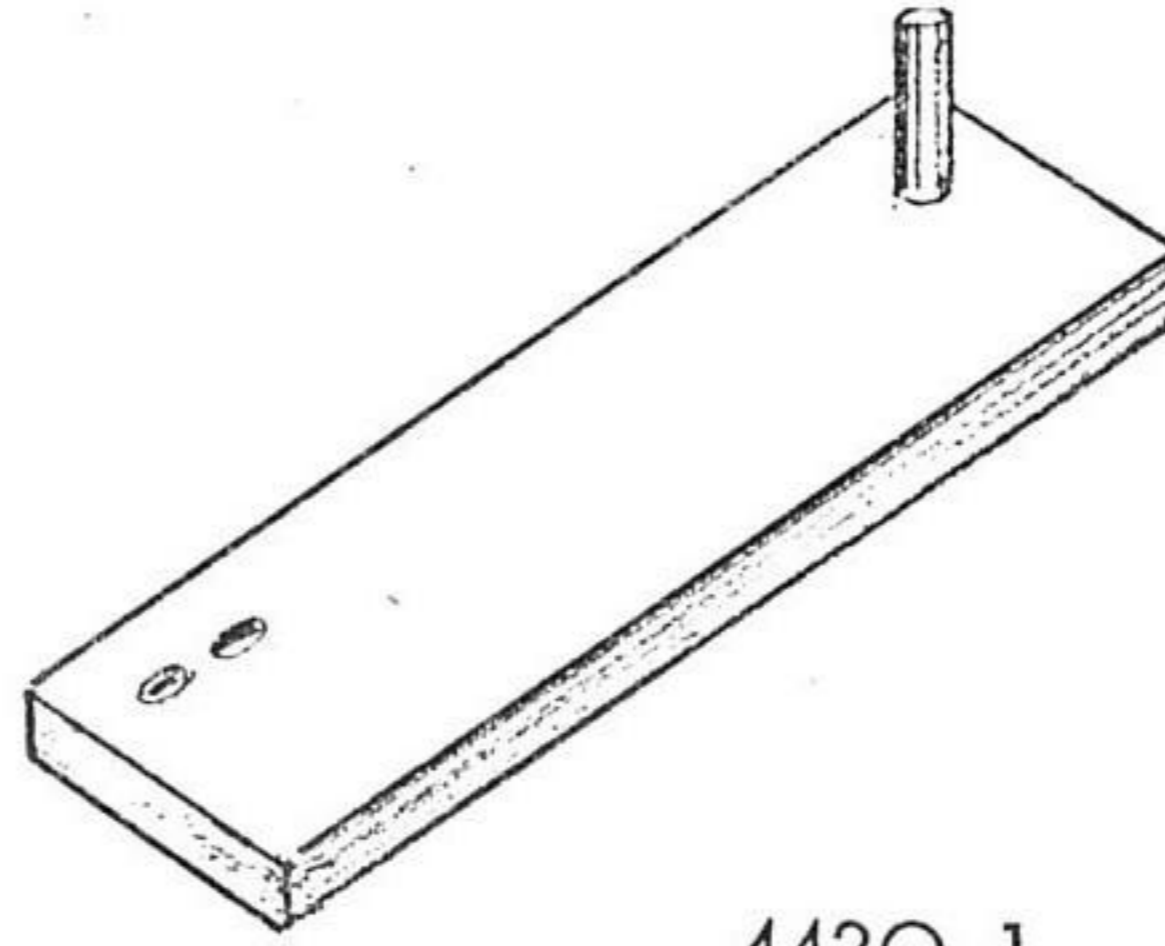
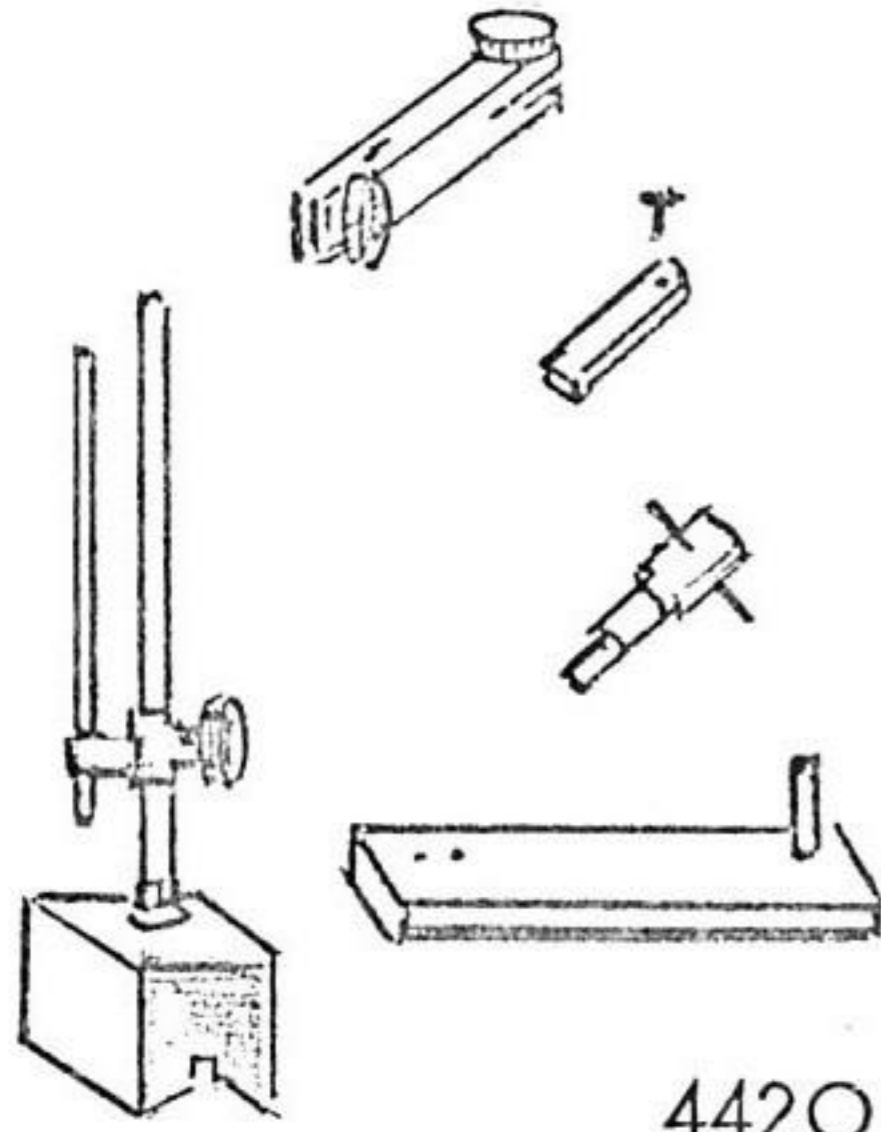

Special TOOLS

FRAME JIG

US 4430

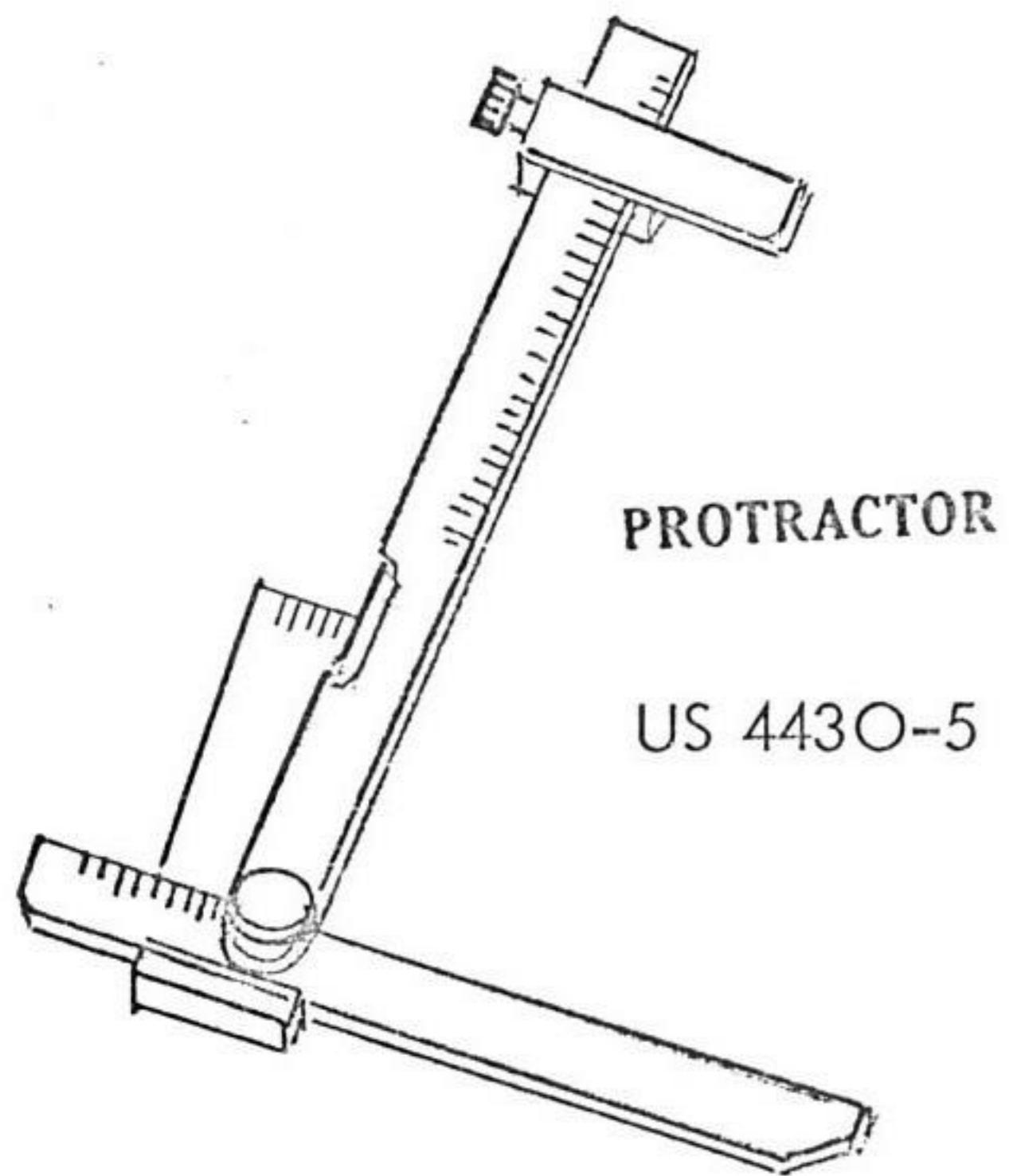
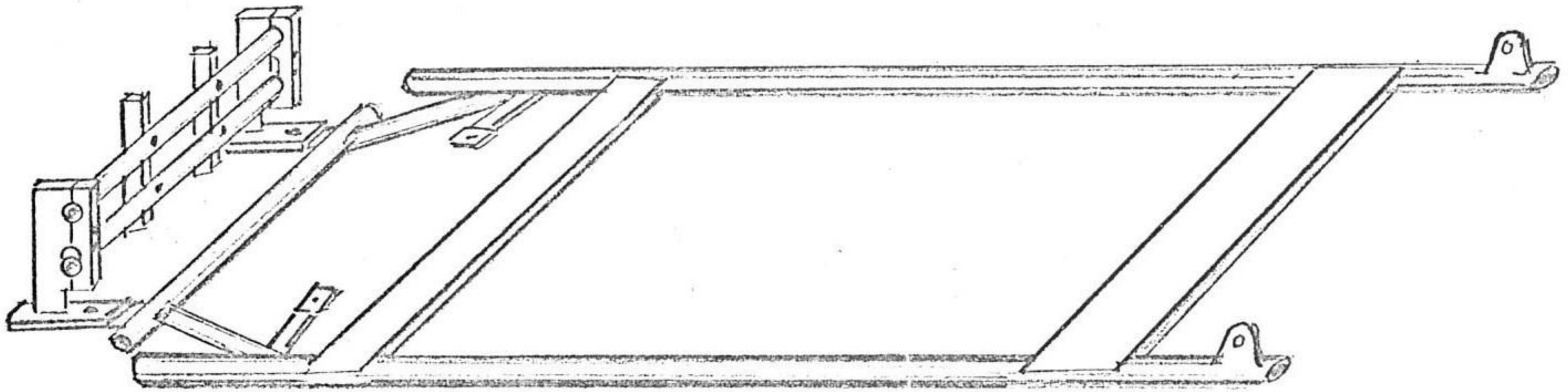

PROTRACTOR

US 4430-5



US 4431

CHECKING TOOLS
FOR AUTOMATIC TRANSMISSION
4 PIECES

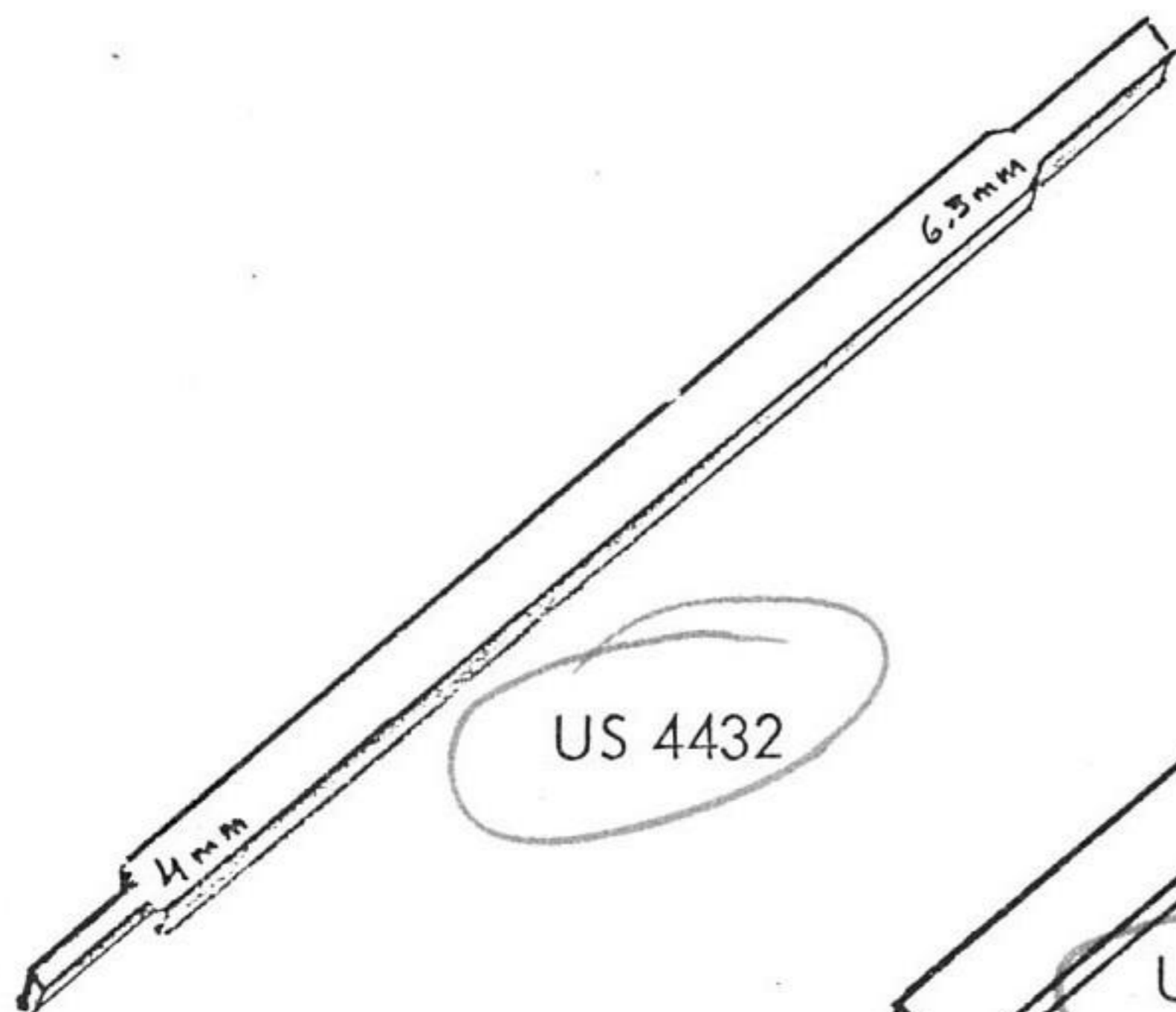

US 4432

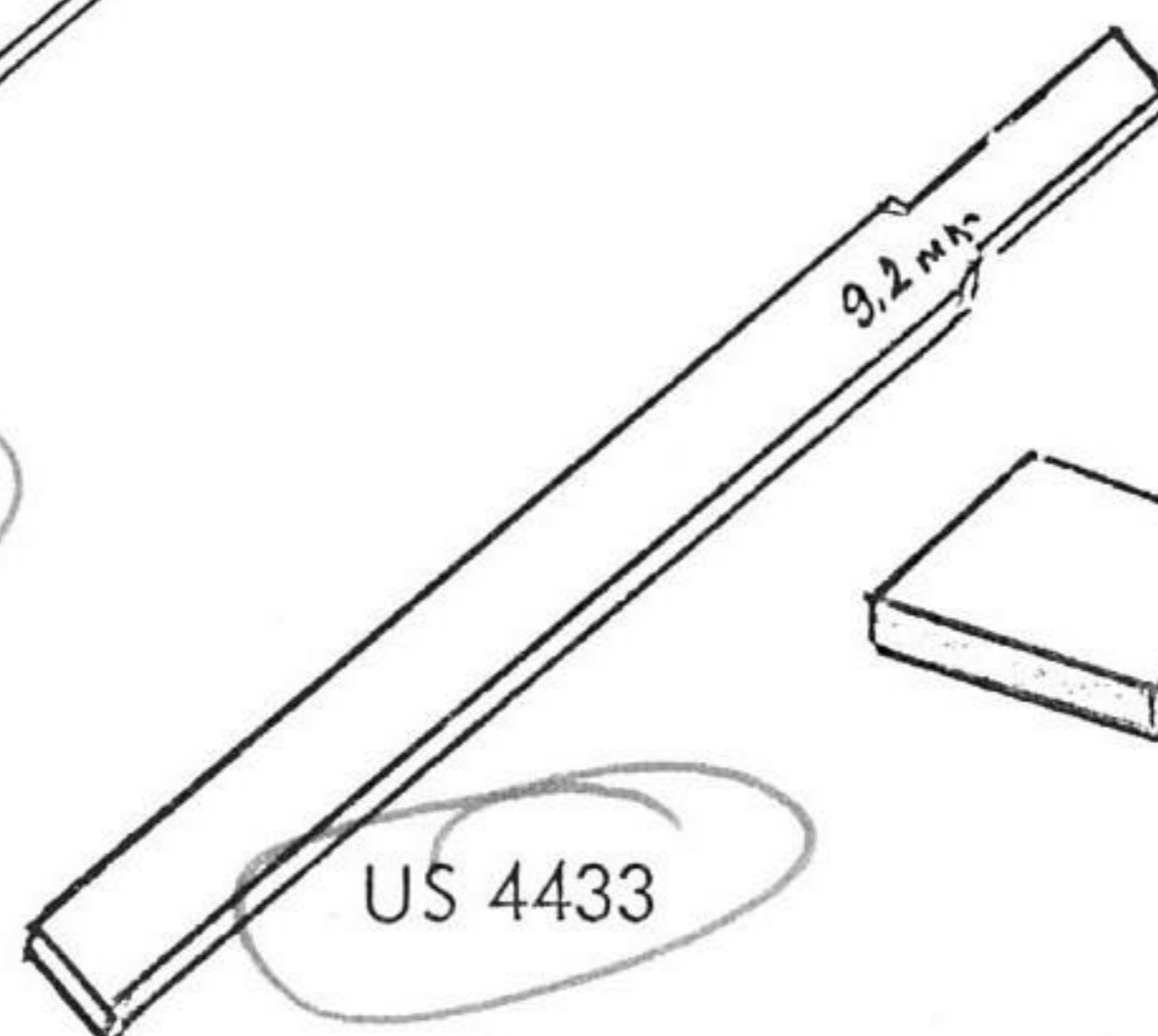

US 4433

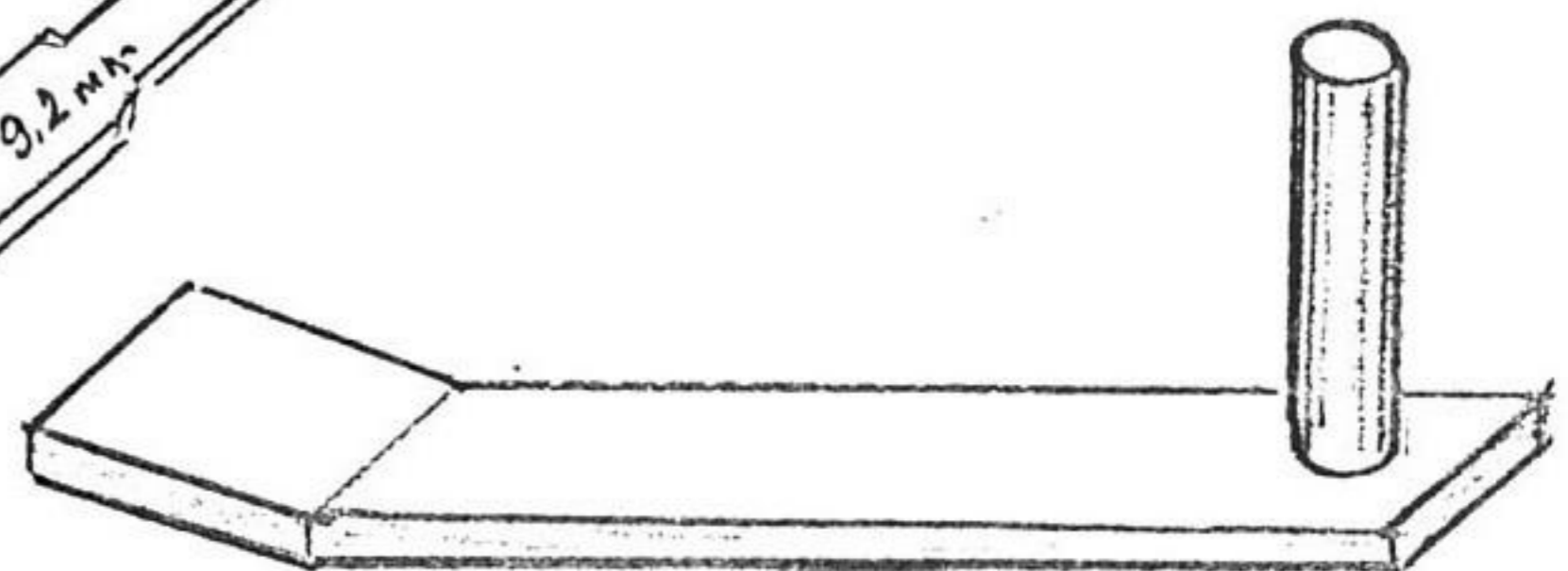

US 4434